

Radio Retailing

The Business Magazine of the Radio Industry

The 2 ampere Tungar will Trickle Charge, too!

Get your share of the big increased demand for 2 ampere Tungars because of this feature. A 2 ampere Tungar will trickle charge a 6 volt battery if clipped on at one post, or give a full rate charge if clipped on another.

Always emphasize this double feature. *It is a strong selling argument.*

This post —
trickle charge
to a 6-volt
battery . . .
Also charges
2- or 4-volt
batteries . . .

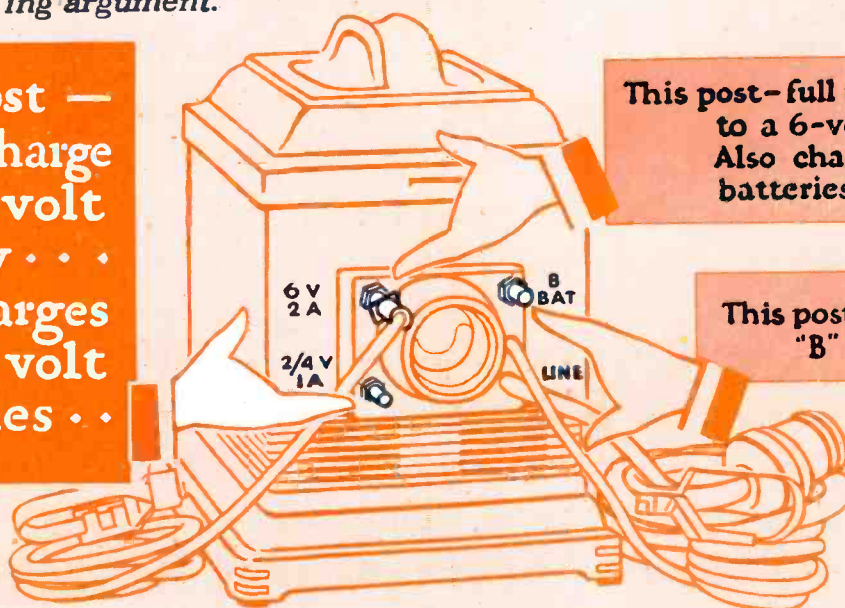

This post—full rate charge
to a 6-volt battery
Also charges auto
batteries

This post—charges all
"B" batteries



Tungar

REG. U.S. PAT. OFF.

BATTERY CHARGER

Merchandise Department
General Electric Company
Bridgeport, Conn.

Tungar—a registered trademark—is found only
on the genuine. Look for it on the name plate

GENERAL ELECTRIC



Our Dealers' Windows

offer to us and to our dealers themselves the most valuable advertising space in the world. We realize this fact and that is why we have created such an attractive series of colorful and artistic seasonal displays in the preparation of which we have spared no expense. We have endeavored to make these displays worthy of the prominent position they are occupying in thousands of Cunningham dealers' windows throughout the country. Increase your Cunningham Radio Tube sales, and therefore your profits, by filling in and mailing the attached coupon. We shall be very glad to mail at once, without any expense to you, these displays. They

are printed in nine colors by a special oil paint process and illustrate all the delightful forms of entertainment that radio brings to the American home.

COUPON

E. T. CUNNINGHAM, INC.
370 Seventh Avenue, New York City.

Gentlemen:

Please put us on your mailing list for the Cunningham Radio Tube seasonal window displays.

Firm Name

Street Address

City and State

Name of your jobber

Jobber's address

Signature of party ordering

E. T. CUNNINGHAM, INC.

NEW YORK

CHICAGO

SAN FRANCISCO

UTAH

CONE

SPEAKER

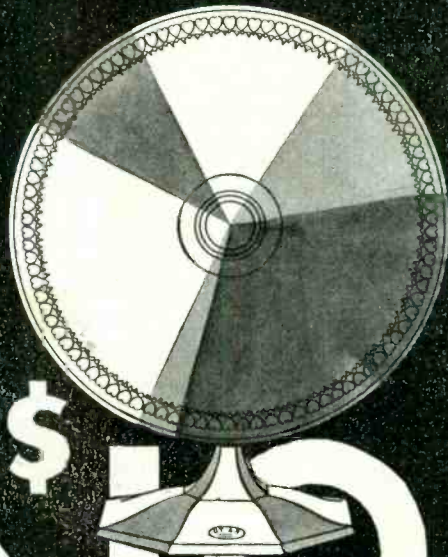

\$ 16



JUNIOR \$12.50



This Cone Speaker is the Famous Leader of the Famous Utah Line

UTAH RADIO PRODUCTS CO., 1421 S. MICHIGAN AVENUE, CHICAGO

THE FAMOUS 17½ INCH UTAH CONE SPEAKER, \$16.00

Each One Guaranteed

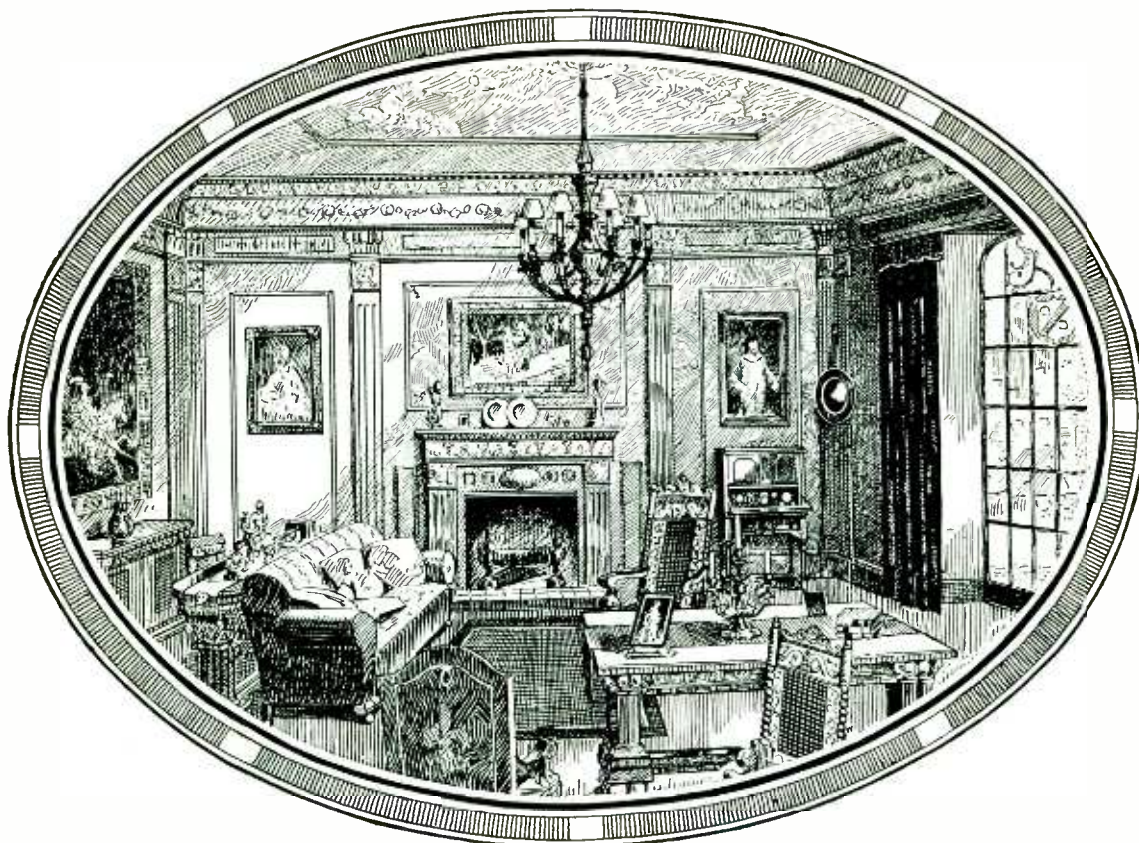

Appealing to Your Choicest Trade!

No. 602. Universal Receiver, Art Console, 6-tubes. Price, less accessories but with external Cone Speaker. East of Rockies \$365; Rockies and West \$400; Canada \$475.

No. 502 Receiver, Art Console, 5-tubes. Price, less accessories but including external Cone Speaker. East of Rockies \$325; Rockies and West \$355; Canada \$380.

No. 7 Wall Type Cone Speaker. Sound board finished in mahogany. Price, including Suspension Cord and Cord for attaching to Receiver. East of Rockies \$30; Rockies and West \$34; Canada \$40.

Other Stromberg-Carlsons range in price, less accessories, as low as \$180 East of the Rockies. \$192.50 Rockies and West; \$225 Canada.



YOUR most influential radio prospects are attracted to your store by your Stromberg-Carlson franchise. Whether they are wealthy, or merely comfortably well off, it is the "lawyer, doctor, merchant, chief," who decide the standards of the "butcher, baker, and candlestick maker," in radio as in automobiles.

It is to this highly desirable clientele that the Stromberg-Carlson particularly appeals. For people of greatest intelligence usually possess the finest appreciation of music in the original, and they recognize in the Stromberg-Carlson an instrument capable of the most flawless musical reproduction.

An increasing number of followers are advertising Stromberg-Carlson leadership more and more every day.

STROMBERG-CARLSON TELEPHONE MFG. CO.
ROCHESTER, NEW YORK

Stromberg-Carlson

Makers of voice transmission and voice reception apparatus for more than thirty years.

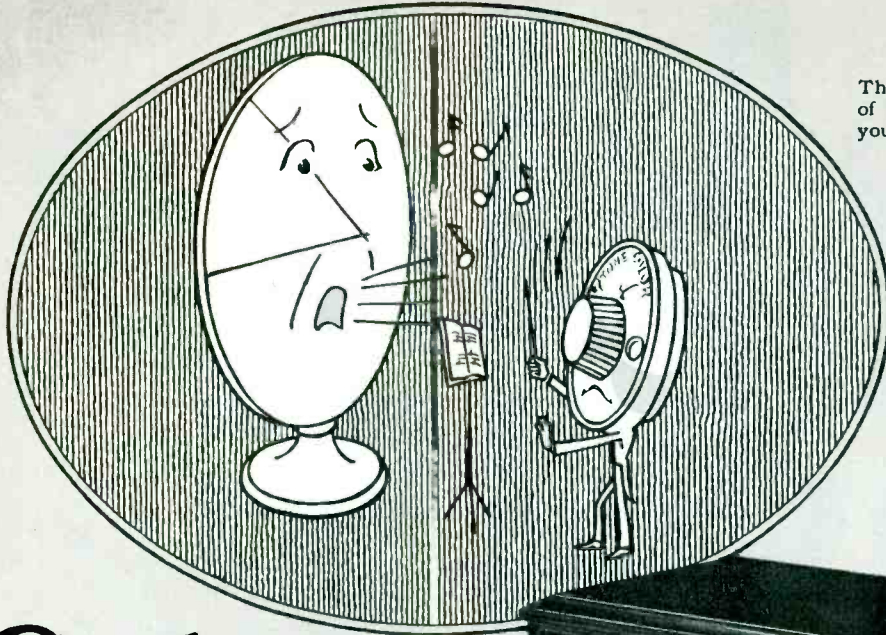

Colortone
 The effective governor
 of tone quality. Gives
 you control of the loud
 speaker's voice.

The Synchrophase
 is also supplied in
 five beautiful
 console models.

Grebe Tone

~ a Great Selling Point



GREBE tone quality is unexcelled in clarity and naturalness. An easily demonstrated statement—hear a Grebe Synchrophase and compare. The ear will decide. But tangible reasons also help you convince your trade: Grebe design and construction and, particularly, the *Colortone*, an exclusive Grebe development.

Let us tell you more about it.
 Send for Booklet RR

A. H. Grebe & Co., Inc., 109 West 57th St., New York City

Factory: Richmond Hill, N. Y.

Western Branch: 443 So. San Pedro St., Los Angeles, Calif.

The oldest exclusive radio manufacturer.

This Company
 broadcasts
 through sta-
 tion W.A.B.C.

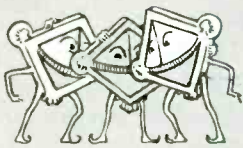

Flexible Unit Control
 which makes the
 Synchrophase a
 One Dial
 Controlled Set.

The GREBE Synchrophase RADIO



because you want results

All Standard Types



Type GSX-112
High power tubes
for use in improv-
ing tone and
volume.
List price \$4.50

Types GSX-201a
and
Gs-201a
The popular gen-
eral purpose type,
for amplifier or de-
tector. Long life
and high efficiency.
List price \$2.00



Type GSX-216B
For use in battery elimi-
nators to rectify alternating
current—advantageous in
supplying the higher cur-
rent required by power
tube equipped sets.
List price \$7.50

Type GSX-171
High power tubes
for use in last stage
of audio amplifica-
tion give increased
volume.
List price \$4.50



Master of the Air!

Profit by the advantages which Gold Seal leadership brings to dealers—profit-making aids such as:

- superior quality, insured by finest materials, design and workmanship.
- a guarantee that means what it says and that is backed by a record of square dealing.
- national advertising that makes customers and helps dealers.
- up-to-date dealer cooperation that really helps.

That is why Gold Seal jobbers and dealers are enthusiastic about this fast selling line. Gold Seal has achieved national recognition on real performance. If you are not yet sharing in its success—don't wait

*Mail this coupon today
and get full particulars*

GOLD SEAL ELECTRICAL CO.
INCORPORATED
250 PARK AVE., NEW YORK

R.R. 2-27 **COUPON**

GOLD SEAL ELECTRICAL CO., Inc.
250 Park Avenue, New York, N. Y.

Gentlemen:—
Please send me full particulars of the
Gold Seal line and your attractive proposition

Name _____

Address _____

City _____

Gold Seal Radio Tubes

Jobbers—A few at-
tractive territories
still open — write
for details at once.

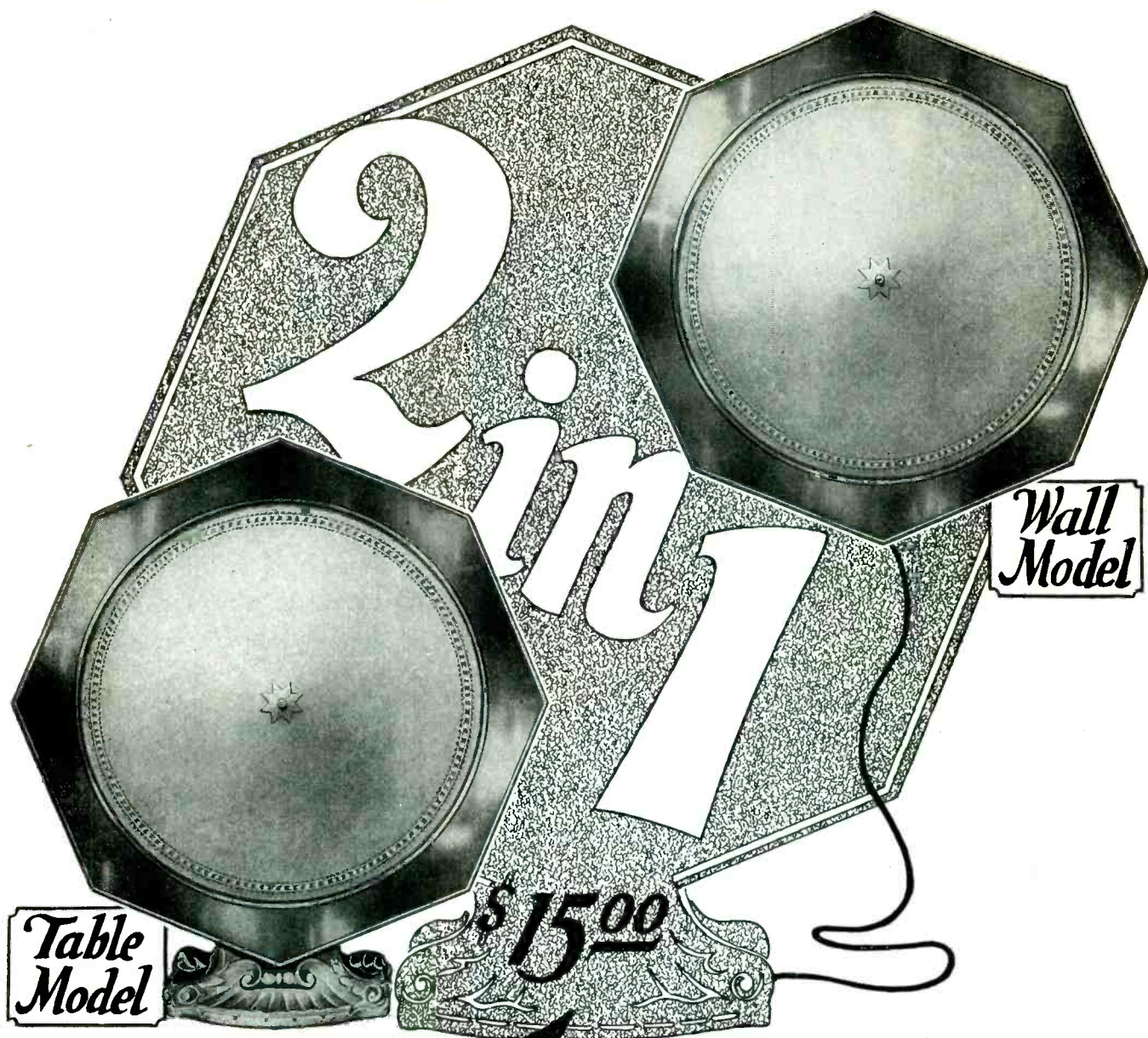

Tower

Meistersinger

CONE

Dealers who chose Tower made money last year. They will make more this year, for Tower is the fastest selling speaker on the market.

In the Meistersinger you have a product of proven merit—one with the widest sales appeal due to its unique design and excellent quality. Use it as a Table Model or detach the art metal base and hang it on the wall from the eyelet provided (15 feet of tinsel cord with each speaker).

This speaker employs a unique direct-drive unit with eight points of contact to the cone (instead of one), and is able to cover the entire musical register. In appearance as well as performance, it reflects the quality associated with more expensive speakers. Packed in wooden boxes with convenient carrying strap.

If you want to speed up your turnover, write us today.

TOWER MFG. CORP., Boston, Mass.

Cone Speakers in 1927

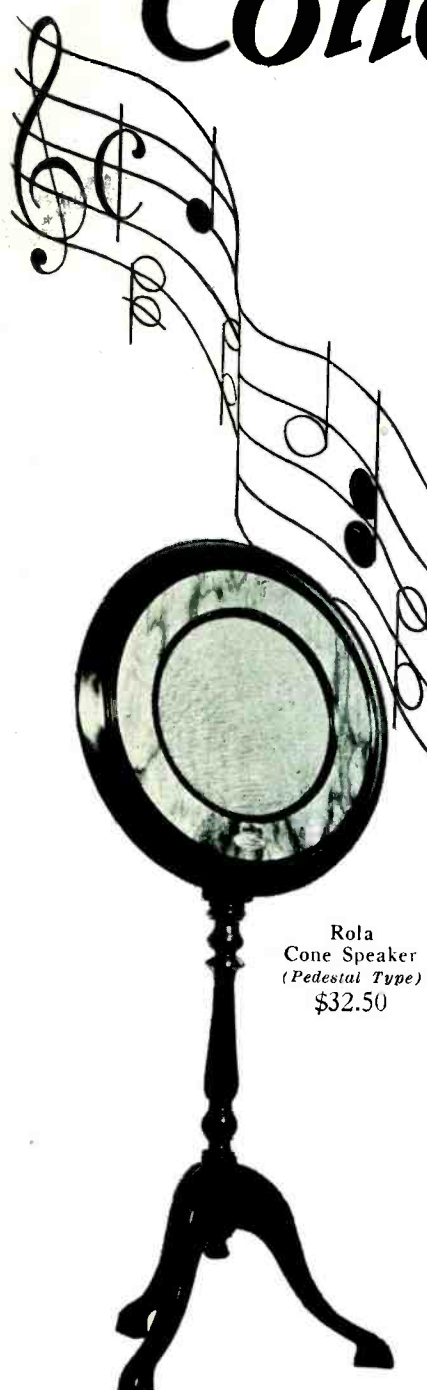

Rola
Cone Speaker
(Pedestal Type)
\$32.50

MARKET authorities estimate that during 1927 cone speakers will outsell all other types ten to one.

You can cash in on this tremendous market with Rola Cone Speakers. For Rola, with its patented laminated armature will give you clear, brilliant reproduction under all conditions—on all radio sets, irrespective of make, type of tubes, or circuit used.

Rola tone-quality, with an irresistible appeal of a beautiful and substantial piece of furniture, forms the profit-winning combination that will treble your loud speaker sales.

If you have not heard the new, improved Rola Cone Speaker, there is a treat in store for you.

There is a generous profit on Rola sales.

Send today for information on the Rola line, and our plan for assisting you in selling Rola Cone Speakers. Mail the coupon.

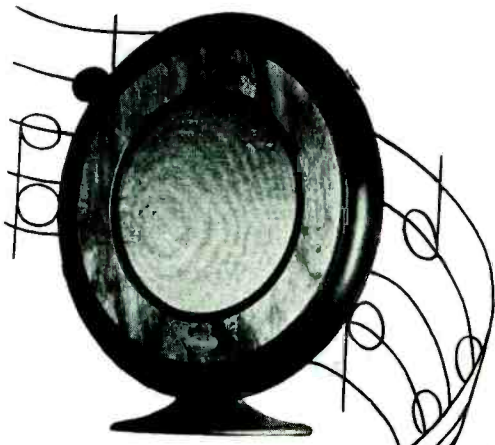

Rola Cone Speaker
(Table Type) . . . \$28.50

Rola

CONE SPEAKERS

The Rola Company, Oakland, California

You may send me particulars.

Name

Address

City State

Jobber's Name

8,000 men

with cash for Radio Sets!

WHICH set to buy? This set had one advantage; that set another—and a dozen others shouted their claims.

But out of it all . . . this fact stood clear in the minds of eight thousand men with cash for radio sets:—

“If Popular Science Monthly has approved the set we will know it is good. So we’ll write to Popular Science.”

And they did! Eight thousand letters asking what sets had been approved by Popular Science Institute of Standards.

And thousands among our 300,000 readers have shopped with confidence in the columns of Popular Science Monthly for their radio sets.

Why this confidence?

The answer is found in this fact: Men read Popular Science Monthly for information.

To them, the advertising pages are news—reliable news—just as the editorial pages are because—No radio product can be advertised there until it

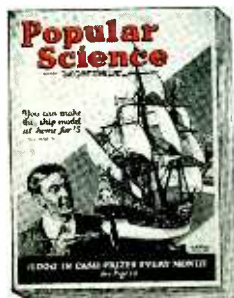

300,000 “interested” men readers pay 25c every month for the practical information contained in the editorial and advertising pages of Popular Science Monthly.

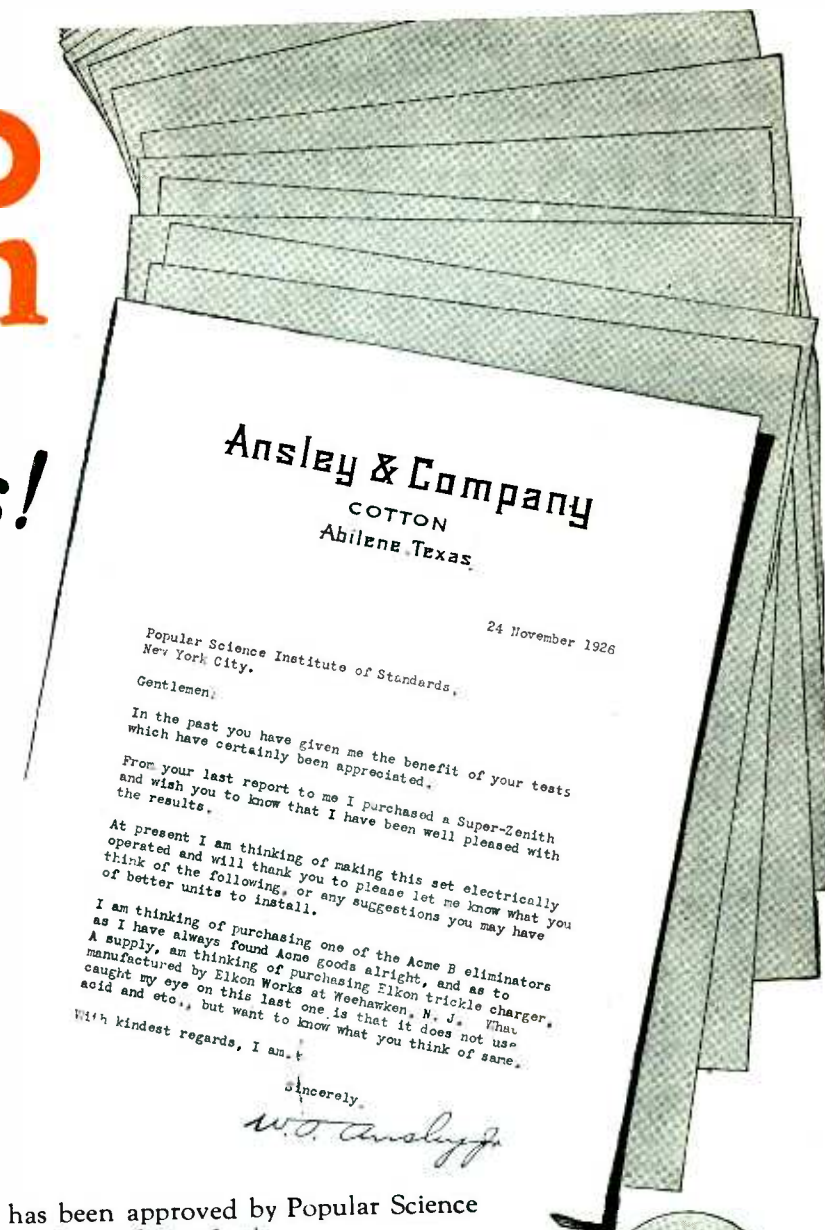

has been approved by Popular Science Institute of Standards.

They are protected! Their purchases are guaranteed!

You, as a radio dealer, know the tedious, time-wasting ordeal the sale of a radio can be.

You’ve met the other type of customer, too. He knows what he wants,—gets it,—and the sale is over. He is the kind who reads Popular Science.

You want more of these quick-acting customers. Write for information about our Dealer-Member Service which keeps you posted on the approved Radio Products which you should have in stock. There is no charge for this Service. Popular Science Monthly, 250 Fourth Avenue, New York City.



Professor Collins P. Bliss, Director of the Popular Science Institute of Standards and Associate Dean, College of Engineering, of New York University.

What is the Popular Science Institute of Standards?

The Institute tests radio apparatus and tools, and approves products of merit. This approval is necessary before such a product can be advertised in Popular Science Monthly. A Buying Guide of approved products is issued on request,—but the magazine itself is literally a buying guide.

Popular Science MONTHLY

More than fine furniture—
follow this selling idea
 and watch your cabinet sales jump!



No. 925
 20x48-in. top
 Solid Mahogany
 with Super Zenith

All Watson town tables are shipped
 in Plywood cases.

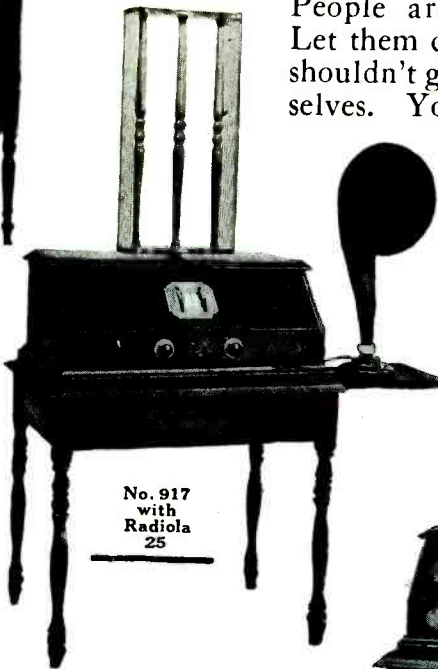

No. 917
 with
 Radiola
 25

Feature
 Your Sets on
 Our Radio Tables

Fine Radio tables to *match* the sets you carry!
 The sets selling fastest today are table models. Think them
 over—Radiola, Atwater-Kent, Crosley, Bosch, and all the
 leaders.

People are buying sets on *performance*.
 Let them choose their own cabinets. Style
 shouldn't govern the choice of the sets them-
 selves. You will have less money tied up
 in stock.

In our new catalog you will
 find fine Radio tables to har-
 monize with all standard sets—
 cabinets that are exceptionally
 well made, yet sell at prices far
 below any other quality line.

Display your sets on these fine
 Radio tables, and provide a
 setting for them that will show
 them off well.



No. 919
 with
 Radiola 20

“A Table for Every Set”



No. 924
 18x22-in. top
 Solid Mahogany
 with Atwater-
 Kent Model 30

READ

what these Repeat Order
 customers say:

“Your tables are the finest we have
 ever handled and at the price, they
 are ahead of anything in the line
 of Radio Furniture.”

“Order arrived in fine condition
 and very much admired.”

“Received our shipment of No.
 924 and very much pleased with
 them.”

“We have uncrated these tables
 and set them up. We like them
 and desire to place another order
 as follows.”

“We have received the Radio
 Tables and Cabinets and are well
 pleased with them, therefore, we
 are sending in another order.”

“Have had some of your tables and
 liked them very much.”

“At the price these cabinets were
 beyond my expectation. I was
 most agreeably surprised.”

WRITE NOW

for Prices and Our Complete
 ILLUSTRATED CATALOG

WATSONTOWN TABLE & FURNITURE CO.

Furniture Manufacturers Since 1893

WATSONTOWN, PA.

TAB - the Rechargeable Dry "B" Battery

45 VOLTS
30 CELLS
\$4.50

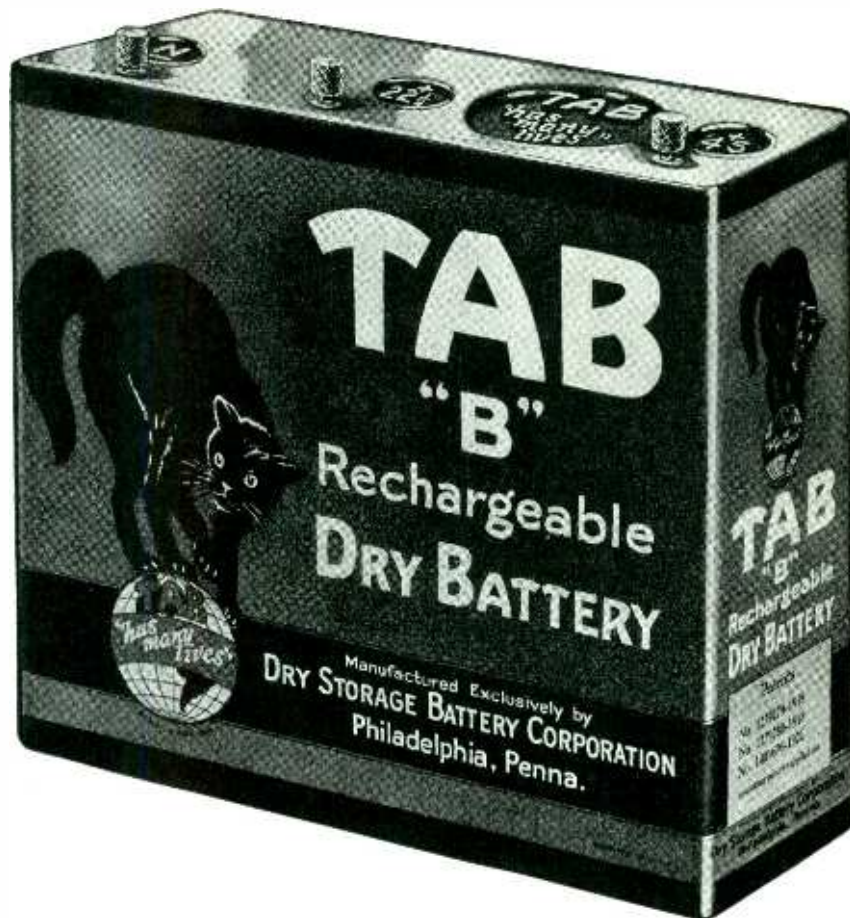

Increasing Popularity

Tab Rechargeable Dry "B" Radio Batteries are sustaining their rapid growth in popularity with Radio users. Every month more and more consumers are appreciating the economy in using Tab Rechargeable Dry "B" Batteries and the improved reception they give.

Longer Shelf Life,—longer original life in use, plus the fact Tab Batteries can be recharged from 6 to 8 times with any standard "B" battery charger is making many new friends for dealers who are displaying and pushing this newest development in the Radio industry.

Write for literature and discounts.

DRY STORAGE BATTERY CORPORATION
213 South Broad Street
PHILADELPHIA, PENNA.

There is no Substitute for a Good "B" Battery in Radio

New

Wirt

CONE SPEAKER

\$20



New in a Number of Notable Ways,—and . . .
Has what every dealer demands—
Tone, Clarity and Volume at a Popular Price

Though the Wirt Speaker embodies all the essentials that the best engineering practice requires in cone speakers, it is not just another that conforms to this type.

The Wirt differs materially in a number of ways. It is not an assembled instrument. Every part is either built in the Wirt plant or specially constructed according to Wirt Specifications.

The highly sensitive reproducing unit was designed by Wirt engineers and is made in the Wirt plant. It is extra large, has exceptional volume, and responds to the slightest

radio impulse. Those finely shaded high and low tones, so often lost in reproduction, are clearly transmitted even when used with sets equipped with power tubes and high voltage batteries.

The cone was specially designed for resonance and tonal quality. A conveniently placed knob at back eliminates need of dismantling speaker for readjustment.

In every particular it is an exceptionally fine instrument, one that you can back to the limit for the makers guarantee it unconditionally.

Prices Changed on

Wirt Radio Lightning
Arrester

Was \$1.00—Now \$1.25

Wirt Radio Wall Insulator
Was \$.35—Now \$.40

We have been forced to raise prices on these two items, but to take care of you we have increased your discount.

Get in touch with your jobber at once.
He will allow you the usual radio discounts.

WIRT COMPANY

PHILADELPHIA, PENNSYLVANIA



Delta

Offers this Combined Trickle Charger
and Full Capacity Charger

The No. 12
**HI-LO "A"
BATTERY
CHARGER**

A TRICKLE CHARGER that can be transformed into a full capacity charger by the turn of a switch! A price that defies all competition! That's the new Delta HI-LO Battery Charger.

There are no moving parts in HI-LO. It's noiseless, and can be used while the set is in operation. A drawn metal case protects bulb and coils. Leads, both to light socket and to battery terminals, are generous in length.

HI-LO uses the new "Superatled" Bulb—guaranteed by Delta—the new style Tungar Bulb No. 277465 or any other bulb of similar style. The "HI" charging rate is about $1\frac{3}{4}$ ampere; the "LO," about $\frac{1}{2}$ ampere.

The rich mahogany baked enamel finish of Delta HI-LO will attract buyers. It's versatility—and price—will sell it. Performance? Delta guarantees that.

Write · Phone · Wire your jobber · or
DELTA ELECTRIC COMPANY
Marion, Indiana

A Sure Profit Maker at **\$10⁰⁰** List Price
Less Bulb



YOUR INSURANCE

A Declaration of Policy

{ NO SURPLUS STOCKS OF FREED-EISEMANN SETS—NO "DUMPING"! }

☐ Your stock of Freed-Eisemann sets is worth its value, and it always will be—that value will be maintained.

☐ The Freed-Eisemann dealer franchise gives *iron-clad* protection and the most liberal dealer discount of any nationally advertised line.

☐ Improvement in design goes forward constantly, but with no drastic changes.

Now is the time when your stock of radio sets needs this protection. Every Freed-Eisemann set is backed by a company of powerful financial strength.

Last Year's Record Doubled!

In New York, America's most competitive market, almost twice as many Freed-Eisemann sets were sold in four months as compared with sales in a similar period last year.

FORGE AHEAD—WITH PROFIT

with

FREED-EISEMANN *Radio*

Assets Over Liabilities \$1,000,000

FREED-EISEMANN RADIO CORPORATION—BROOKLYN, NEW YORK



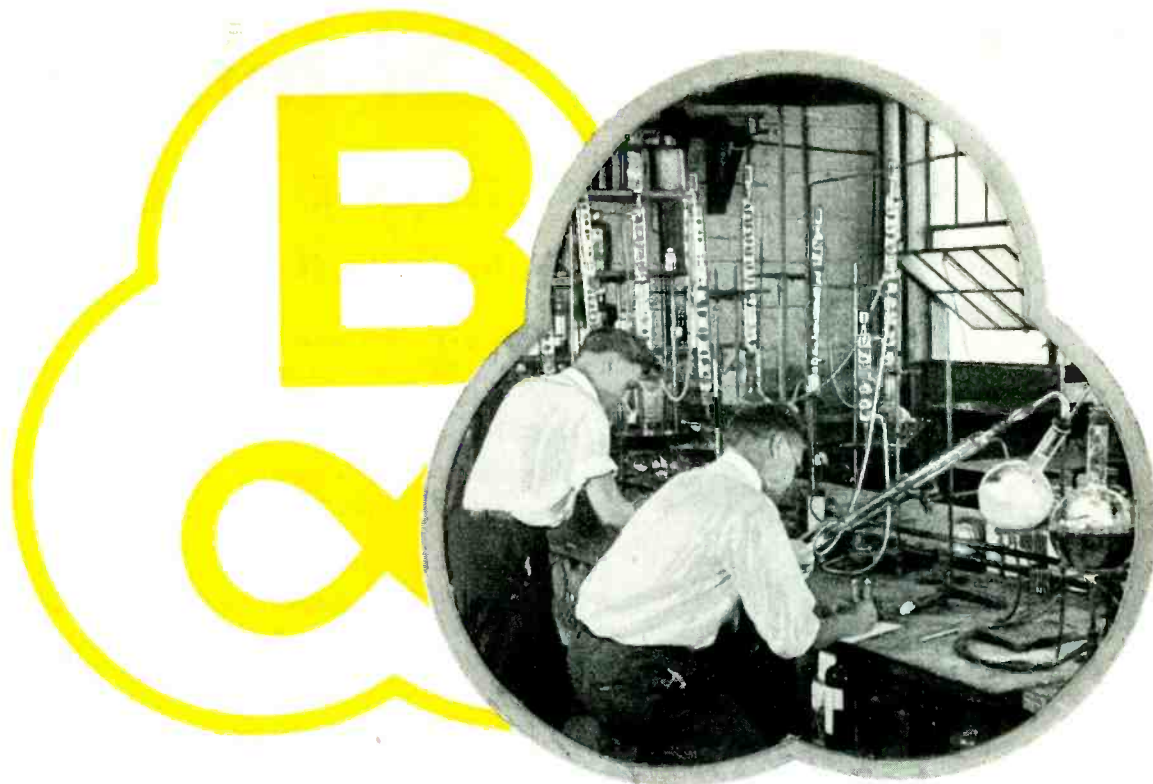

Why you should make sure it is **BAKELITE**

Any radio set, speaker or part is no better than the insulation used in it. When insulation value is impaired, performance is correspondingly impaired.

No material used by the radio industry is surrounded by more safeguards during manufacture than Bakelite. A score or more of chemists and engineers, in laboratories provided with the finest equipment that science has devised, not only analyze the raw materials and test each run of Bakelite, but they conduct experi-

ments to widen its field of usefulness and inaugurate continuous improvements.

A staff of Bakelite field engineers cooperate with radio manufacturers, and are at their service to determine the exact form or grade of Bakelite best suited for a given application. You, and your customers, benefit by all of this exacting care when you make certain that the radio equipment you handle is genuine Bakelite. Look for the trade-mark "Bakelite" on parts or cartons.

BAKELITE CORPORATION

247 Park Ave., New York, N. Y. Chicago Office: 636 W. 22nd St.
BAKELITE CORP. OF CANADA, LTD., 163 Dufferin Street, Toronto, Ontario

BAKELITE

REGISTERED

U. S. PAT. OFF.



THE MATERIAL OF A THOUSAND USES

The registered Trade Mark and Symbol shown above may be used only on products made from materials manufactured by Bakelite Corporation. Under the capital "B" is the numerical sign for infinity, or unlimited quantity. It symbolizes the infinite number of present and future uses of Bakelite Corporation's products.

When your Customers ask these questions about B-power

Do you answer them correctly?

“Are B-eliminators really satisfactory?”

Absolutely. There must be nearly a million of them in service, many of them on the biggest and most powerful receivers. Your reception cannot be at its best unless you always have ample power and voltage.

Light socket power is the only way to keep the B-voltage right up to snuff all the time.

“Which type of rectification is best?”

The chemical and filament rectifiers are good, but the trend favors the Raytheon rectifier. More than twenty of the leading manufacturers have adopted this tube, which is now becoming standard for B-power service.

“Are all Raytheon-equipped B-power units alike?”

No, indeed. They are as different as the companies who make them. Some of them are designed for smaller sets, some of them will handle any set. But all of them have passed certain minimum essential requirements in the Raytheon laboratory. All of them have been designed for use with the reliable Raytheon tube which is guaranteed for a year by the Raytheon Manufacturing Company.

“Will I be able to get Raytheon tubes for replacements in the years to come?”

Yes. The temporary shortage during the past few months was due to an unprecedented demand which could not be anticipated, and the Raytheon Company refused to sacrifice quality for quantity production. They now have greatly increased facilities which insures the future supply. In fact, more Raytheons are being made right now than the total of all other B-power rectifiers combined.

“Should I buy Raytheon type B or type BH for replacement?”

Buy the tube which came with the unit when it was new. If your unit was designed for the type B tube, that tube should be used for replacement. Otherwise the extra voltage from the BH tube might prove excessive. The BH tube was designed for special applications where extra power and voltage are needed but, in the service for which it was designed, no tube can surpass Raytheon, type B.

“Do you own stock in the Raytheon Company?”

No, but I want you to buy equipment which will keep you satisfied, and which you will be proud to show your friends. That's why I recommend this Raytheon-equipped unit. I know it's backed by sound engineering and dependable business people. That combination, together with the long life Raytheon rectifying tube, is unbeatable.

Raytheon Manufacturing Company
Cambridge, Mass.



In the
Blue and
Orange
Box

JOBBERS

- Atlantic Sales Co., Dallas, Tex.
- Automotive Appliance Co., Dallas, Tex.
- Automotive Supply Co.
124 Washington Ave. N., Minn. Minn.
- Geo. D. Barbey
4th & Walnut Sts., Reading, Pa.
- Beardsley Specialty Co., Rock Island, Ill.
- Sanford M. Bookey
221 Fulton St., N. Y. C.
- Charles Leonard Hardware Co.
Petersburg, Va.
- Cogdell Auto Supply Co.
Fort Worth, Texas
- Craghead Engineering Co.
325 Main St., Cincinnati, Ohio
- Dallas Radio Laboratories, Dallas, Tex.
- Famous Auto Supply Co., Zenia, O.
- Hardwicke Etter Co., Sherman, Tex.
- Harris Hardware Co.
Washington, N. Caro.
- Higgenbotham, Bailey, Logan Co.
Dallas, Texas
- Horst & Wilkinson, Davenport, Iowa
- K. O. Tire Stores
2144 Grand River Ave., Detroit, Mich.
- R. W. Kumble,
13186 Pinehurst St., Detroit, Mich.
- L. & L. Auto Supply Co.
Sioux Falls, So. Dak.
- Lockwood Radio Co., Inc.
637 Market St., Philadelphia, Pa.
- Mackenzie Radio Corp.
1225 Broadway, New York City
- Main, W. F. Co. Cedar Rapids, Iowa
- Francis S. Megargee
Adams & Linden Sts., Scranton, Pa.
- Monarch Electric Co.
Adams & Desplaines St., Chicago, Ill.
- Moore Bros. Electric Co., Dallas, Tex.
- Moore, John M. Co., Okmulga, Okla.
- Nash Hardware Co., Fort Worth, Tex.
- National Accessories, Inc.
2051 Farnam St., Omaha, Nebr.
- Parsons & Whittemore
299 Broadway, New York City
- Perfection Sales Co., Fort Madison, Iowa
- Plank Products Co., Grand Island, Nebr.
- Plant Auto Equipment Co. Minn, Minn.
- Rice-Stix, D. G. Co.
Dept. No. 62, St. Louis, Mo.
- Schullkopf Co., The Dallas, Texas
- Scientific Electrical Service Lab., 115
N. Broad St., Philadelphia, Pa.
- Seesholts Fowler Radio Co.
113 No. Market St., Wichita, Kans.
- Self, J. M. Supply Co.
511 N. Broadway, Okla., City, Okla.
- Sickles & Preston Co.
Davenport, Iowa
- Smith-Meyling Battery Co.
Keokuk, Iowa
- Standard Laboratories
1406 Walnut St., Kansas City
Mo.
- Sternberg, H. D. Corp.
148-152 Broad St., Rochester.
N. Y.
- Straus Co., The
Locust & 27th, St. Louis, Mo.
- Vim Cycle Hardware Corp.
137 Broadway, Buffalo, N. Y.
- Wholesale Radio Co.
211 N. 10th St., St. Louis, Mo.
- Wireless Electric Co.
206 Stanwix St., Pittsburgh.
- Rudolph Wurlitzer Co.
121 E. Fourth St., Cincinnati.
- Zwiebel-Stenger Sales Co.
203 So. Main St., Wilkes-
Barre, Pa.



Heretofore when the dealer consented to stocking a new make of tube, he was satisfied if half the virtues *claimed* for it came *true*. But now, with the introduction of the new Clear Glass Zetka Process Tube, claims become *facts*.

"Unsilvered"—these tubes actually repower the performance of every set. The faint signal of a DX comes through with "local" volume and smoothness. There are no metallic noises. And such welcome features as extra long life—no deterioration—minimum "B" consumption, and a plate voltage range of from 22½ to 250 volts (*impossible for sustained performance with any other 201 A type tube.*)

To give conclusive proof of Zetka Process superiority the Zetka Laboratories are equipping their dealers with the finest Weston meters—these meters forming the base of a giant tube display with high attention value. Tested in the meter before the purchaser they *tell* their own story and consequently *sell* their own way into thousands of new homes, with all risk of rash claims removed.

You can realize what a tube of this character will do in increasing tube sales. It is the tube you have waited for—the tube your customers should insist upon.

**The revolutionary, new clear glass Zetka Process has been adapted to a complete line of Power Tubes. The clear glass tube in the Blue and Orange box.*

A "proof-positive" way to double daily sales.



The Zetka Tube Tester with an interesting sales proposition can be had upon request.

ZETKA
The Clear Glass Tube

ZETKA LABORATORIES, Inc.
73 WINTHROP STREET
NEWARK, N. J.

SONOCHORDE

The Speaker of Eloquence

SONOCHORDE

CONE Try This

Special Invitation Offer—

Order a sample! Test it! Compare it! If Sonochorde does not equal or exceed your expectations, we'll refund your money!

Heretofore, dealers have not been able to get Sonochordes fast enough to supply the demand. Now, for the first time in two years, due to day and night production in our new factory, we are making immediate deliveries.

Sonochorde, with its rich, wine colored silk front, protected back, mahogany finished metal frame and base, and patented unit with sixteen exclusive features, is offered in 3 models—Floor, Table and Wall. Note Coupon. Use it!

Manufacturers
BOUDETTE MFG. CO
 Chelsea, Mass.

Factory Sales Agents
HASTINGS ELECTRIC SALES CO.
 42 Binford St., Boston, Mass.



Floor Standard

A model much in vogue. Includes all Sonochorde Features. Price \$35.

**MAIL THIS
 MEMO
 COUPON**

BOUDETTE MFG. CO., Chelsea, Mass.
 Send me complete Sonochorde details—
 rush.

.....



\$25

STEWART-WARNER



This beautiful walnut console is a recent addition to the Stewart-Warner line. One dial, six tubes.

Our Protective Policy
is Making Money for
Thousands of Dealers
It Will Interest You

The Stewart-Warner Protective Policy

Stewart-Warner Blue Ribbon Dealers are selected and served by our exclusive distributors, the Stewart-Warner Wholesale Radio Distributors.

As each distributor has a definite territory, he can give his dealers unusual protection. Prices are maintained, and a Stewart-Warner Dealer doesn't walk around the corner to find his prospects being sold by another Stewart-Warner Dealer. He is given the opportunity to carry on a real business in his immediate neighborhood—an opportunity to make money. The success of our Dealers is our success.

A Complete Line

With a complete line ranging from the popular-priced table models to the handsomely designed consoles, Stewart-Warner Blue Ribbon Dealers are enabled to sell *all* prospects who wish to purchase a quality receiver made by a well-known manufacturer.

Distributors' Service to Dealers

As Stewart-Warner Wholesale Distributors are handling Stewart-Warner exclusively and are not interested in other radio lines, Stewart-Warner Dealers receive a maximum amount of service. Every Distributor has a trained technical man whose services are at the disposal of our dealers.

National, Year-'Round Advertising

Throughout the year, Stewart-Warner Matched-Unit Radio is kept before the public eye. Magazines, outdoor painted billboards, posters, newspapers and broadcast advertising will all be made use of during 1927.

STEWART-WARNER SPEEDOMETER CORPORATION
1820 DIVERSEY PARKWAY, CHICAGO, U. S. A.

Stewart-Warner



IT STAYS SOLD!
No "IFS", "ANDS"
or "BUTS"

THE FARRAND "B" Eliminator is a little higher in price, BUT.....it is trouble-free and stays sold! No matter the type of set, no matter the number of tubes, it does its job completely, perfectly, without a whimper or a let-down—providing up to 200 volts, if necessary. Get in touch with your distributor TODAY. Begin featuring Farrand "B" Eliminators NOW while the demand is at its height.

FARRAND MFG.CO., Inc.
 LONG ISLAND CITY / NEW YORK

Farrand Heavy Duty
"B" ELIMINATOR

- made by the makers
 of the famous
Farrand
Speaker

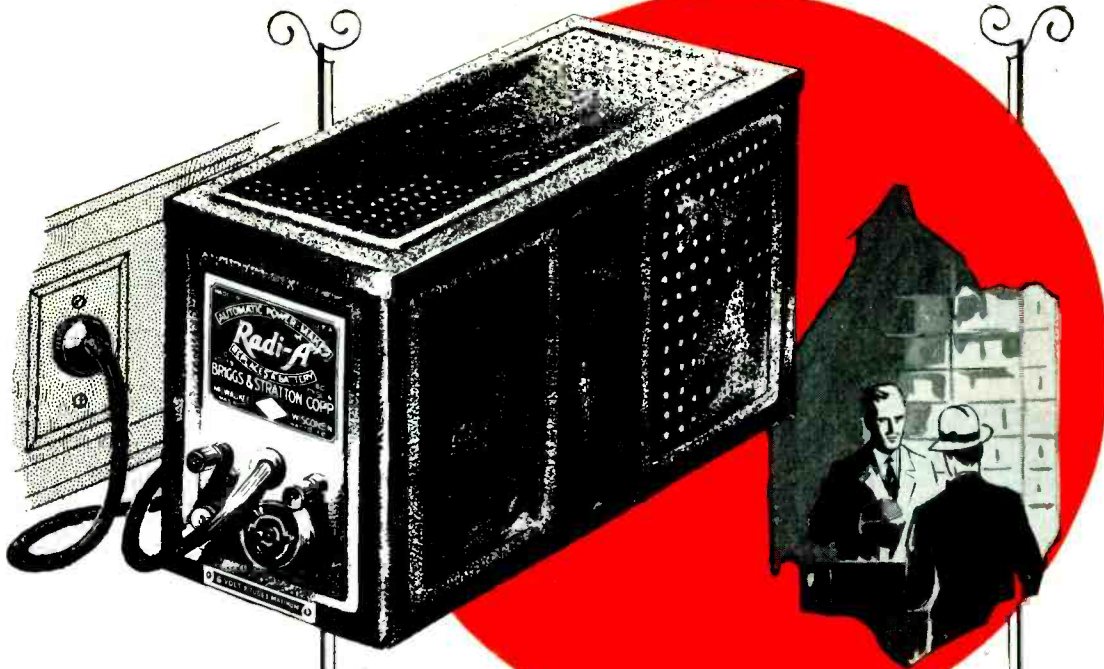

**Radi-"A"
Assures
Maximum
Reception
ALWAYS**

**Three Styles Adapted
to All Radio Sets:**

Radi-"A" may be operated from any 110-volt 50 or 60 cycle electric power line.

Radi-"A" 6-Volt Standard is for use with radio receivers of 4 to 8 quarter-ampere tubes inclusive. It develops a 6-volt direct current of 2 to 2 3/4 amperes.

Radi-"A" 6-Volt Special is for use with sets of 8 to 10 quarter-ampere tubes inclusive only, and develops a 6-volt current with a maximum output of 3 amperes.

Radi-"A" 4-Volt is made for any set using up to 12 No. 199 UV tubes inclusive.



**This Dealer Sold 74
Radi-"A"s in 3 Months!**

RINZEL-TESCH, Inc., are dealers in musical instruments, phonographs, radio receivers and Radi-"A", the recently perfectly light-socket "A" power unit.

Although located in a "workingman's neighborhood", this dealer sold 74 Radi-"A" units in three months, representing a dollars-and-cents volume of more than \$3,600.00 on this one item.

Rinzel-Tesch order Radi-"A" in dozen lots to keep pace with the demand.

Every Radi-"A" sold by them is working satisfactorily—and they do not employ a single service man. Rinzel-Tesch attribute their success in selling Radi-"A" to:

1. The superior performance of this instrument as compared with other light-socket "A" power units designed to do the same work.
2. Rinzel-Tesch's personal endorsement of Radi-"A".
3. The Briggs & Stratton Corporation's Radi-"A" guarantee.

You can apply these same factors to the successful sale of Radi-"A" to your customers and profit accordingly. Write for descriptive circular and ask your jobber about Radi-"A".

BRIGGS & STRATTON CORPORATION
MILWAUKEE, WISCONSIN

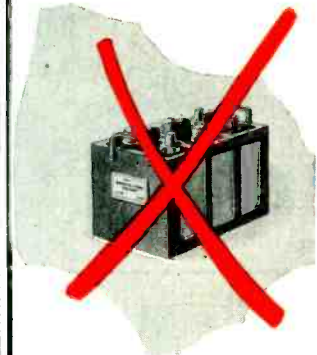

**"A"
Power
from Light
Socket**

Radi-"A"

**Replaces
"A" Battery and Charger**

AMRAD

AMRAD CORPORATION Harold J. Power, Pres. Medford Hillside, Mass.



Here's a "B" Eliminator that Equals fresh new "B" batteries

B eliminators usually fail to give reproduction qualities to your radio that come from fresh, new B batteries. First class B eliminators are usually quiet in operation and supply proper voltage and current, but the reproduction in the loud speaker is faulty because the capacity of the eliminator is not sufficient for the tremendous drain of current accessible loud or low notes demand. Such eliminators must draw the current all the way from the lamp socket through the filter choke into the receiver. The time element is appreciable so that the peaks of any notes are chopped off, which causes distortion.

The Amrad B eliminator employs the famous Mershon Condenser as the principal capacity unit. This famous condenser has many times the capacity of any other eliminator condenser and constantly provides you with a sufficient supply of energy for the correct reproduction of any sounds that may come through your radio.

The Mershon Condenser

*freshens up old "B" eliminators
and prolongs life in "B" batteries*



The Mershon Condenser assists in more perfect filtering (straining) of the uneven current supplied by a lamp socket. It also acts as a reservoir to store a large amount of energy which is necessary for a continuous smooth flow demanded by incoming broadcasts. This energy, such as fresh B batteries deliver, must be on tap instantaneously for large substantial musical notes. The improvement in tone quality is particularly noticeable on low notes.

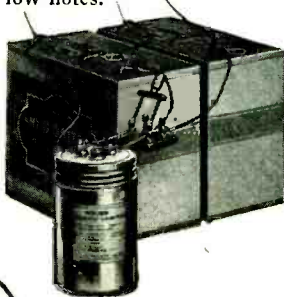

Mershon Condenser connected across B batteries (with a disconnecting switch) greatly prolongs useful life of these dry cells. It in itself does not wear out—can be used continuously.

\$8.

Free from Break-downs

Paper condensers now used in B eliminators frequently break-down. Here the Mershon has such a large capacity that any excessive voltage surges are eliminated; the charge being instantly absorbed. This also protects the receiver set against punctured parts or insulation break-down.

Won't Get Noisy

Nor are there any variable adjustments to get out of order. All parts are readily accessible as no compound or other filler is used in its manufacture. The Amrad B power unit is mounted on a metal base and incased in steel box, black enamel finish.

This as well as the other products of the Amrad Corporation are a tribute to the engineering skill of the Amrad laboratories and the influence of mass production methods of Powel Crosley, Jr.

Write Dept. SB7 for descriptive literature.

\$35.

*including the celebrated
Amrad S-1 tube*

Adopted
by
Radio
Leaders

PHILCO

Balkite

Stromberg-Carlson

KELLOGG

GAROB

MU-RAD

BROWNING-DRAKE

**Hammarlund
ROBERTS
Hi-Q**

Griess



The FREE Cabinet Is Speeding Up Durham Sales Order Yours Today!

This New Durham Counter Display Cabinet will speed up your Durham sales just as it is increasing sales for every dealer who has put it on his counter. Takes little room. Attracts attention. Holds complete supply of Durham Resistors and Mountings—handy—easy to get at and SELL!

As long as limited supply lasts we are furnishing these cabinets to our dealers who order stock to fill—50 assorted Resistors and 5 each of single and double Durham Mountings. Total list \$30.75—less regular discounts. Order direct and give name of your jobber.

DURHAM METALLIZED RESISTORS

Selected as Standard by Leading Radio Engineers

INTERNATIONAL RESISTANCE COMPANY
Dept. J, Perry Building, Philadelphia, Pa.

Kolster

Surprise

Lake Village, Ark.

The Kolster is certainly a "HUMDINGER!" We have tried out some of the very best, but here in this remote location we are able to get a great list of stations, even in the daytime.

Bucyrus, Ohio

The Kolster is a perfect instrument. All you read about it is more than true. In listening to it you feel as though you are in the presence of an artist.

San Antonio, Texas

The Kolster is undoubtedly the very best and finest radio built at the present time. We have been able to outperform any other standard radio built within \$100 of the price.

New Bedford, Mass.

The Kolster outperforms any instrument we have ever handled and we have handled a good many different makes.

West Barrington, R. I.

The Kolster is the most selective I have ever operated. The tonal quality of the Kolster is unsurpassed. I have logged 90 stations in a few weeks.

Girard, Ill.

We think more of our Kolster franchise than all others we have had anything to do with. Nothing else sounds good to us for there is nothing to take the place of Kolster's tonal quality.

Coffeyville, Kansas

The Kolster line this year seems to me to be the best that it is possible for any dealer to handle. The sixes are marvelous and as for the eights—well, I just can't describe them, they are just too good for words.

Hannibal, Mo.

To say we are enthusiastic over the Kolster line is putting it mildly. There are very few people in our City today who do not own a Kolster and who wouldn't like to own one. **WE WOULDN'T TAKE \$5,000 CASH FOR THE KOLSTER FRANCHISE.**

Warrensburg, Mo.

The Kolster is certainly there with the goods. Very simple to operate which appeals to the women. Good tone, plenty of selectivity and volume.

Fort Myers, Fla.

We firmly believe the Kolster to be the best instrument obtainable and have come to this conclusion after making comparisons.

FROM all over the country letters are pouring in from dealers and owners telling of the wonderful results obtained from Kolsters.

This spontaneous acclaim confirms our policy of letting Kolsters prove their own superiority by demonstration.

Read what dealers like yourself have to say about Kolsters.

Farmington, W. Va.

I have been in the radio game since 1913, starting as an amateur with a small spark transmitter, and have followed the development of radio broadcasting very closely since its inception. It is a pleasure to tell you that the Kolster is the best receiver I have ever heard.

Bowmanstown, Pa.

We have never heard a radio so wonderful as the Kolster. We have asked our jobber to consider our application for the Kolster franchise and we feel if you will grant us this most valuable franchise, we can do a most wonderful job for you.

Lansing, Mich.

In less than three hours after receiving a Kolster, we got 48 stations, including all throughout the Southeast and two of the California stations. It is absolutely the best set I have ever operated.

Waterford, Pa.

It seems to me that the Kolster is the last word in receiving sets. In this case it is certainly—"Hearing is believing."

Kolster-

FEDERAL-BRANDS, INC.

Results Dealers

WE made no claims—To distributors and dealers we said the same, "Hear a Kolster." We asked dealers to say the same to customers.

For we were convinced that Kolster superiority was self-evident. The wisdom of such a policy has been confirmed.

If you have not yet heard a Kolster, request a demonstration of your jobber, or mail us the coupon below at once.

Los Gatos, Cal.

We are very enthusiastic over the Kolster. The different parties we demonstrated the sets to were so well satisfied with their performance that they did not want to listen to any other sets. To demonstrate a Kolster is to sell it.

New Orleans, La.

The first time we tried out the Kolster we got Pittsburgh, Cincinnati, Chicago, Omaha, St. Louis, Denver, Fort Worth, Houston and others. We received more volume than any set I have ever listened to.

Aberdeen, So. Dak.

The Kolster is certainly going fine in South Dakota and it is a pleasure to have such a wonderful set to sell.

San Antonio, Texas

We have just had word from a customer who says, "In all my years of experience with radio, the Kolster is the finest instrument I have ever heard."

Brandes

Woolworth Building, New York, N. Y.

Cumberland, Md.

After serving 12 years in the U. S. Navy, after handling every type of receptor since the days of the slide tuner and crystal with one earpiece, I want to state right here that the Kolster is the finest set I have ever operated. Volume, selectivity, and simplicity are certainly remarkable.

Fair Haven, Vt.

A customer of ours told us that he had owned several receiving sets before the Kolster, but is most enthusiastic over the Kolster, saying that he gets all near-by stations with fine volume and gets as distant a station as Fort Worth, Texas.

Fayette, Mo.

We consider the Kolster in a class by itself and do not know of any radio that compares with it in tone quality volume and distance.

Baltimore, Md.

The Kolster is marvelous. Every demonstration means a sale.

Youngstown, Ohio

We certainly would not want to trade our Kolster franchise for any other line. We know from experience that the Kolster gives the truest representation of the human voice with the proper amount of volume.

Chicago, Ill.

We do not know of any receiver on the market that we would rather sell or own personally than the Kolster.

Concord Junction, Mass.

The reports we receive from our customers of Kolster sets confirm our belief that they are the finest money can buy. Starting the dial at 0 and turning it slowly brings in stations faster than they can be written down

FEDERAL-BRANDES, Inc.
 Woolworth Bldg.,
 New York, N. Y.

Please arrange a Kolster-Brandes demonstration. It is understood that this does not obligate me.

Name

Street

City.....State.....

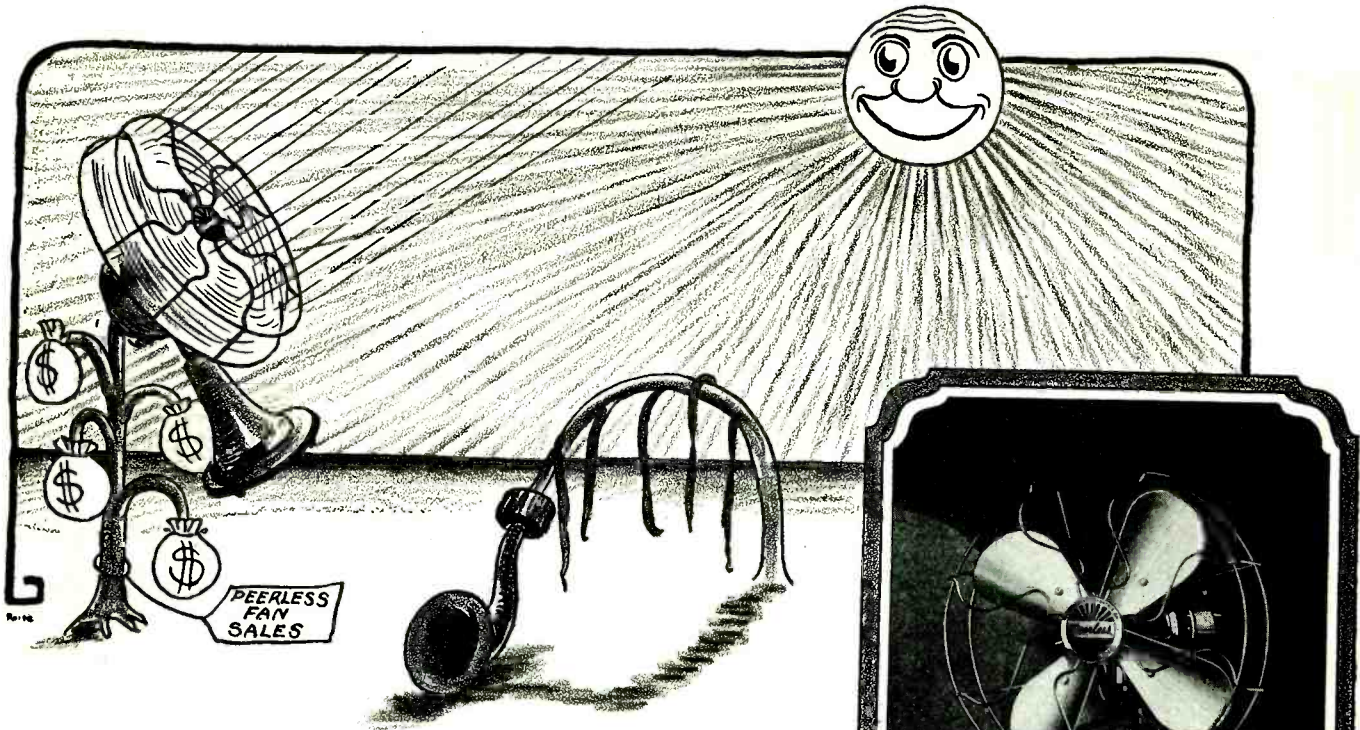

When Ole' Sol wilts radio sales— Peerless Fan sales bloom

Radio sale is a winter plant—the fierce blaze of summer sun wilts it instantly.

But the hotter the sun shines, the more Peerless Fan sales flourish and bloom into profits—summer is the time when people buy fans.

So—why not sell Peerless Fans in summer when you can't sell radio?

The same salesmen—the same stores—the same distribution machinery is perfectly adapted to fans. You can keep your sales force—inside or outside—together—make your floor and window space worth something, and write the summer's business in black ink instead of red.

Peerless Fans sell—ask anybody who has tried them—they have the power, the quality, the moderate price.

And above all, the profit is good.

Write for more information—beat Ole Sol at his own game.

The Peerless Electric Co.

WARREN, OHIO

The Silent
Peerless Fan

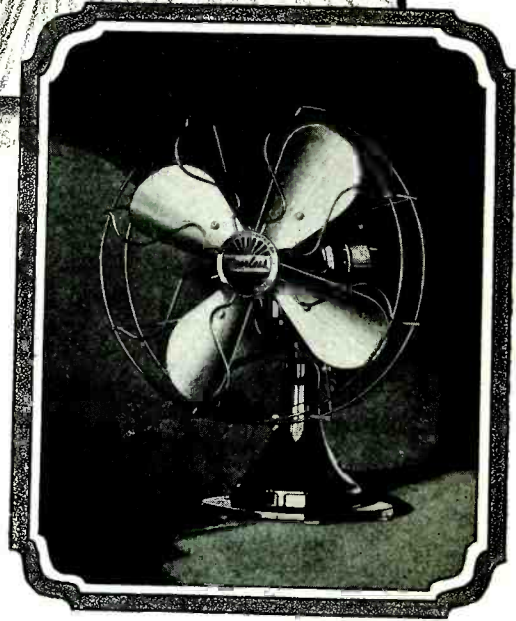

**Radio for
Winter—**

**Peerless
Fans for
Summer**



Sylvania

TUBES

"The Better Tube"

Every dealer who sells Sylvania Radio Tubes gets these double barreled selling advantages—

1. Consistent advertising and complete dealer co-operation.
2. A quality tube that has created a new high standard in clear radio reception and is unconditionally guaranteed.

An unbeatable combination that means a steady turnover and profits to every Sylvania dealer.

*Write for the
Sylvania proposition.*



SYLVANIA PRODUCTS CO.
EMPORIUM, PENNA.

NEUTRODYNE

—the name that's famous everywhere—the principle of
successful home radio—upheld by the courts

The basis of dealer success

FAMOUS

Millions of dollars have been spent during the past four years in advertising Neutrodyne not only in America, but throughout the world. It is probably the most famous and valuable trade name in radio today. And that value is stable, permanent. For Neutrodyne is a trade-mark registered in the United States Patent Office, and similarly protected in other countries. No one may use it except those authorized by its owner, the Hazeltine Corporation, and its exclusive licensee, the Independent Radio Manufacturers, Incorporated. The protection of this most valuable name is the protection of every dealer in Neutrodyne receivers.

PRINCIPLE

But Neutrodyne as a trade-mark has come to mean more than a trade name—it is a principle. It is the principle that has given the name a value tremendously greater than the total amount spent in advertising it. For the public demands not only nationally advertised goods, but good goods. And because Neutrodyne radio receivers are products of outstanding merit, they have created, and are creating today, many retail fortunes.

UPHELD

Neutrodyne's legal position has been upheld by the United States Courts. Here, in substance, are the outstanding facts about Neutrodyne performance as found by the courts:

NEUTRODYNE was the first receiver to take the squeals and howls out of radio. NEUTRODYNE was the first receiver that "was not a nuisance in the neighborhood."

NEUTRODYNE was the first receiver to give simple tuning to radio.

NEUTRODYNE was the first receiver to permit "logging" of broadcast stations.

NEUTRODYNE was the first receiver to bring each station to one definite place on the dials, and to that place alone.

Ask yourself if you can afford to do business in radio without Neutrodyne.

The following fourteen manufacturers are the only ones licensed to make Neutrodyne receivers and the protection of distributors and dealers against patent infringement liability, maintained by the Hazeltine Corporation and Independent Radio Manufacturers, Incorporated, applies to none other than Neutrodyne receivers:

THE AMRAD CORPORATION
Medford Hillside, Mass.
F. A. D. ANDREA, Inc.
New York City
CARLOYD ELECTRIC & RADIO COMPANY
Newark, N. J.
EAGLE RADIO CO.
Newark, N. J.
FREED-EISEMANN RADIO CORPORATION
Brooklyn, N. Y.

HAZELTINE CORPORATION

(Sole owner of "Neutrodyne" patents and trade-marks)

GAROD CORPORATION
Belleville, N. J.
GILFILLAN RADIO CORPORATION
Los Angeles, Cal.
HOWARD RADIO COMPANY, Inc.
Chicago, Ill.
KING-HINNERS RADIO COMPANY, Inc.
Buffalo, N. Y.
WM. MURDOCK CO.
Chelsea, Mass.

STROMBERG-CARLSON TELEPHONE
MANUFACTURING COMPANY
Rochester, N. Y.

R. E. THOMPSON MANUFACTURING CO.
Jersey City, N. J.

WARE RADIO CORPORATION
New York City

THE WORK-RITE MANUFACTURING CO.
Cleveland, Ohio

INDEPENDENT RADIO MANUFACTURERS, INCORPORATED

(Exclusive licensee of Hazeltine Corporation)



It is your protection
against patent infringement liability

KELLOGG

Radio

Flawless Reproduction

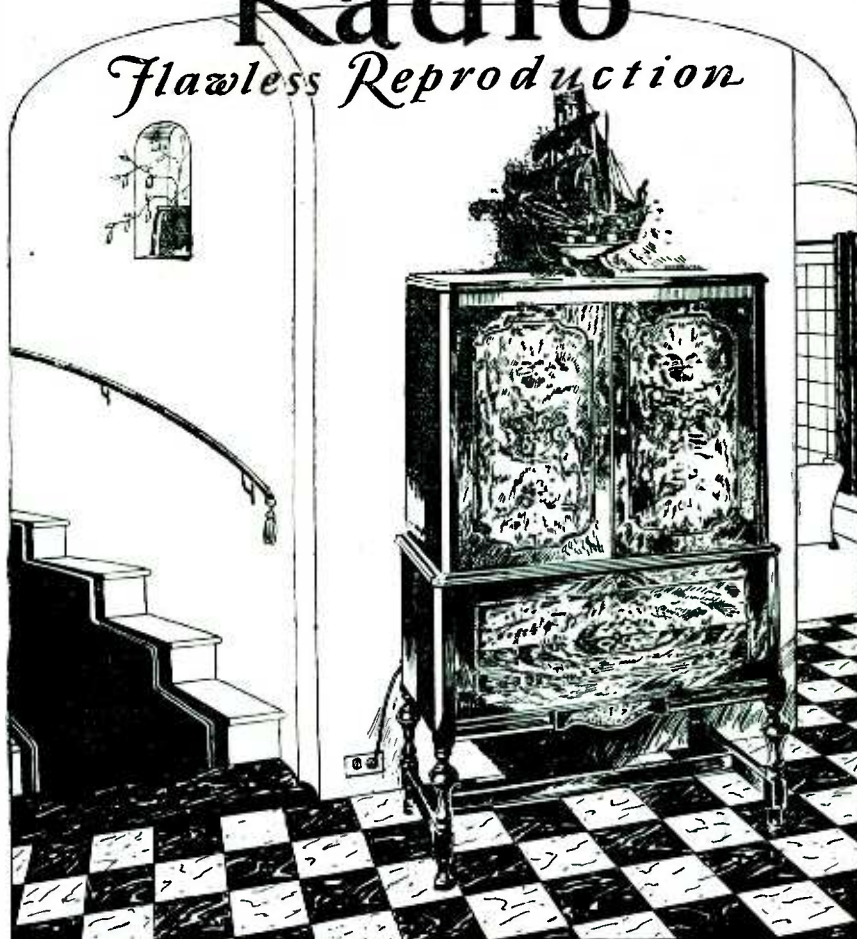

NOW is the Time to Get Set for 1927

THE 1927 radio year is beginning NOW—not next June.

Right now is the time to get posted on the opportunities that Kellogg offers to the dealer who is not content with the past—however good it may have been—but who is looking to the future for bigger business and greater net profits.

To such dealers, Kellogg's 1927 merchandising plans will be full of interest. We believe we can open your eyes to new possibilities of volume and of profit and we shall be glad to receive your invitation to discuss the matter with you.

A line from you will enable us to present this all-important subject for your consideration without entailing any obligation on your part.

Kellogg Switchboard & Supply Co.

Dept. 12-B, 1066 West Adams St., Chicago

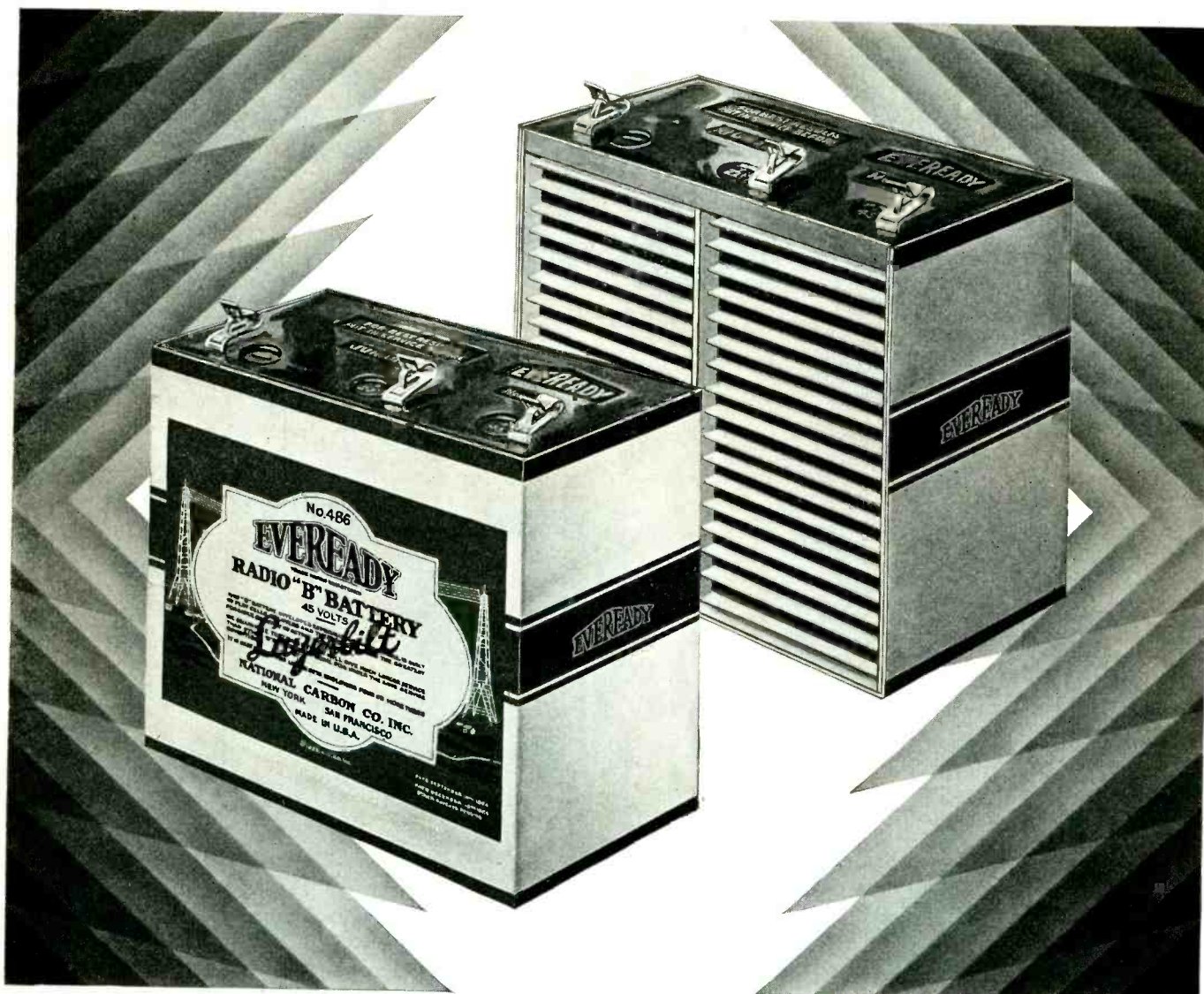

This is the battery that adds to the dealer's prestige

THE Eveready Layerbilt is absolutely the longest lasting dry cell "B" battery ever developed, as proved by the experience of thousands of dealers and of radio users. Modern sets that "chew up" the smaller Light-Duty size of battery are easily handled by the Eveready Layerbilt. You can unhesitatingly recommend it for all loud-speaker sets.

The remarkable service of the Eveready Layerbilt is due to its unique, patented construction. All other dry cell "B" batteries are assembled of cylindrical cells, with much waste space between

them, and many soldered connections bridging the gaps. The Eveready Layerbilt, however, is built of *flat* layers of current-producing materials, making automatic connection with each other. Every available inch inside the battery case is occupied usefully. This construction gives the user more battery for his money, and that battery is more efficient.

Don't let the public think that the smaller Light-Duty batteries, because they cost somewhat less, are more economical. The Eveready Layerbilt lasts more than twice as long, and doesn't cost

anything like twice as much. It is by far the most economical to use and the most satisfactory for you to sell.

NATIONAL CARBON CO., Inc.
New York San Francisco
Atlanta Chicago Kansas City
Unit of Union Carbide and Carbon Corporation

Tuesday night is Eveready Hour Night
—9 P. M., Eastern Standard Time,
through the following stations:

WEAF—New York	WTAM—Cleveland
WJAR—Providence	WWJ—Detroit
WEEB—Boston	WGN—Chicago
WTAC—Worcester	WOC—Davenport
WFL—Philadelphia	WCCO—Minneapolis
WGR—Buffalo	WCCO—St. Paul
WCAE—Pittsburgh	KSD—St. Louis
WSAT—Cincinnati	WRC—Washington
	WGY—Schenectady

VESTA

Quality Radio Units

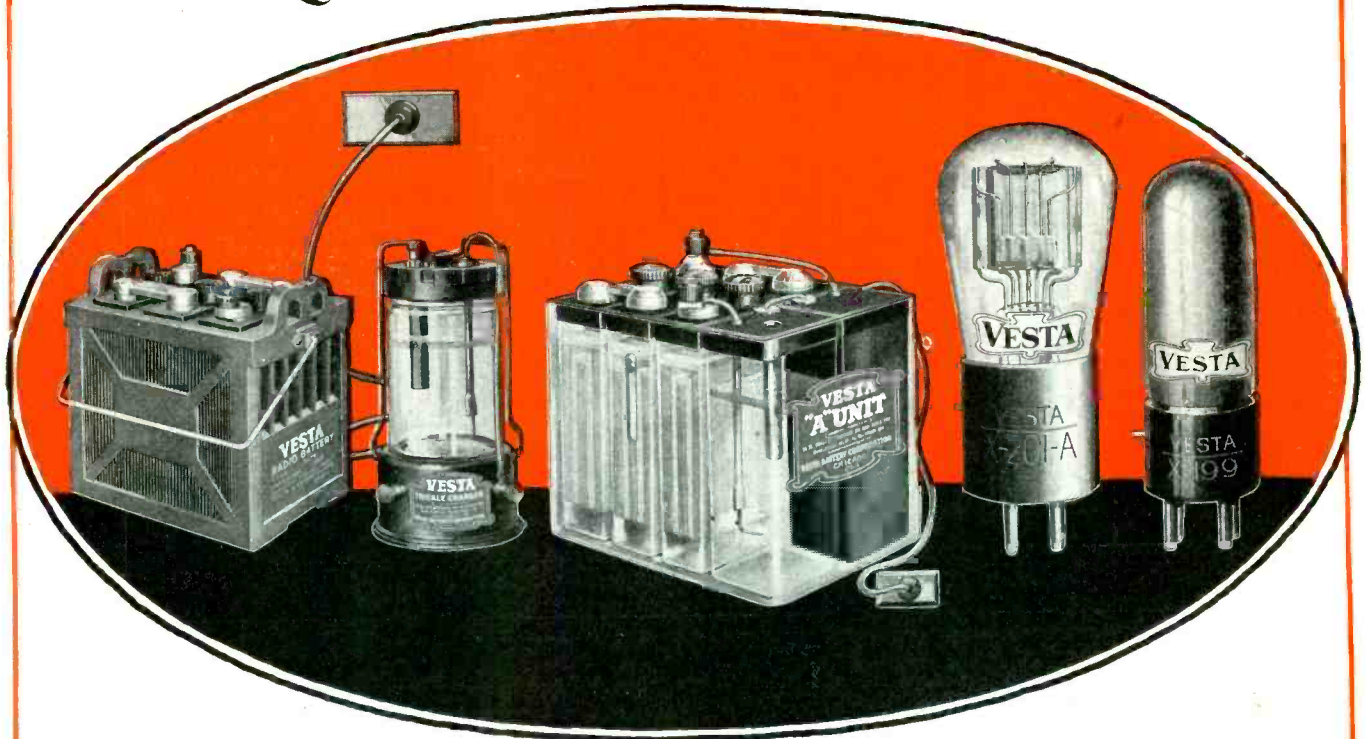

RADIO "A" BATTERY *reduced in price*

The highest type radio "A" Battery—now at a lower price—effective Feb. 1st. Vesta Radio Batteries have over-size plates and separators for longer life and power.

Light-Socket Radio "A" Power Unit

Trickle Charger and "A" Battery all in one clear glass case with Built-in Hydrometer. 2 capacities: 25 Amp. \$25.00. 50 Amp, \$27.50. Pacific Coast, add \$1.50.

Light-Socket Trickle Charger

keeps the battery at full charge. Hooks up with light socket. Safe, economical and noiseless. List \$10. Pacific Coast, \$10.50.

The Vesta Non-microphonic Tubes

New construction, minimizing damage in shipping and handling. No more grief because of damaged filaments or microphonic noises.
X-201A Vesta Tube \$2.
199 Vesta Tube \$2.25.
X-171 Vesta Tube \$4.50

For the Success of Your Radio Department

IN your search for radio units that will minimize the cost and annoyance of trouble and . . . on the other hand, render such satisfactory service that customers will speak highly of your line—

—let us direct your attention to the Vesta Quality Units. It means real money to you to build good will, especially at this stage of the radio business.

Put Vesta Units to the test—and learn first hand of this quality that will promote the success of your radio department.

VESTA BATTERY CORPORATION
2100 Indiana Ave., Chicago, U.S.A.

*Makers of Vesta Quality Automobile
and Radio Batteries — for 30 Years*

Mail coupon
to nearest Vesta
Central or
VESTA BATTERY
CORP.
2100 Indiana Ave., Chicago.
Please have your Central Distributor
near me present the Vesta
 Radio Line Auto Battery Line

Name.....
Address.....
City..... State.....
R. R., Feb.

WRITE HERE

TUNE IN WFKB — VESTA BROADCASTING STATION — 217.3 METERS

ATWATER KENT RADIO

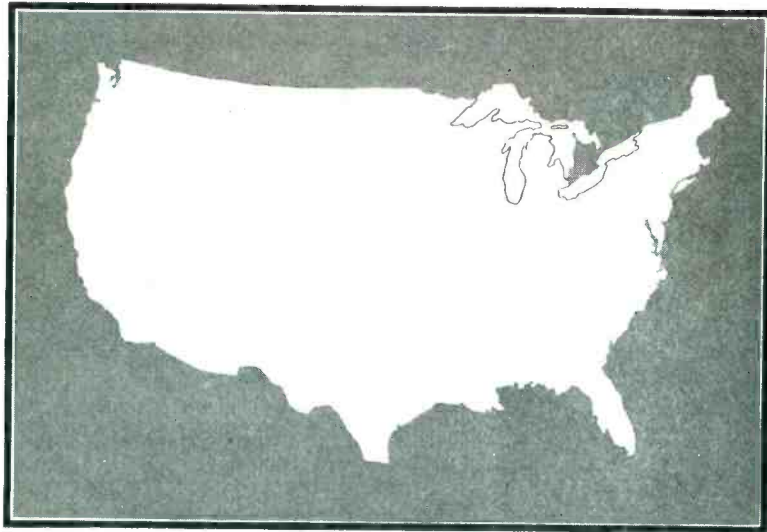

It isn't even sprinkled

THERE ARE 6,000,000 radio receivers in American homes—and more than 1,000,000 of them are Atwater Kent Receivers.

Sounds like a lot? It is.

But put it the other way: There are 27,000,000 homes—and 21,000,000 of them—three out of four—have no radio!

Who can talk of a saturated market when—

- 63 per cent of homes have automobiles
- 42 per cent have phonographs
- 65 per cent have telephones
- 55 per cent have electricity
- 22 per cent have radio**

ONLY 22 per cent have what *everybody* wants—radio! And a very large number of the sets now in use are relics of the past—home-made or otherwise obsolete—and will have to be replaced.

The market saturated? It isn't even sprinkled!

We doubled our sales in 1925. Thanks to the enthusiastic cooperation of our dealers and the advent of the Atwater Kent ONE Dial Receiver, we doubled them *again* in 1926.

For 1927—who in your town have Radio and who haven't? And who among the present owners are ready for better sets—the irresistible Atwater Kent ONE Dial Receivers which no one can try without wanting?

Write for illustrated booklet telling the complete story of Atwater Kent Radio

ATWATER KENT MFG. CO.
A. Atwater Kent, President
4738 WISSAHICKON AVENUE
PHILADELPHIA, PA.

MODEL 35, illustrated, 6-tube ONE Dial Receiver, less tubes and batteries, but with battery cable attached, \$70. Speaker, Model H, \$21.

Prices slightly higher from the Rockies west, and in Canada



EARL WHITEHORNE,
Contributing Editor
S. J. RYAN,
Merchandising Counsellor
L. E. MOFFATT,
Associate Editor
H. S. KNOWLTON, *Boston*
PAUL WOOTON, *Washington*

Radio Retailing

The Business Magazine of the Radio Industry

O. H. CALDWELL, *Editor*

WILLIAM C. ALLEY,
Acting Managing Editor
RAY V. SUTLIFFE,
Western Editor, Chicago
HENRY W. BAUKAT,
Technical Editor
WILLIAM W. McDONALD,
Assistant Editor
C. GRUNSKY, *San Francisco*

Table of Contents February, 1927

"Why Didn't I Make Money Selling Radio Last Year?"	32
The 1927-1928 Trends in Cabinet and Circuit Designs	36
Advertising—Making Every Dollar Spent Bring in 15 More	38
When Price-Cutting Failed—He Made Service Pay	41
Capitalizing the Quality Market	43
Radio Legislation in Sight	45
Know Your Business at a Glance	48
Television Among Month's Radio Events	51
Separating Those Who Buy from Those Who Talk	52
Analyzing the World Market for Radio Equipment	54
Sandwiches and DX for the Guests	56
What This Industry Needs	57
For the Service Department	60
Audio Frequency Amplifying Units	63
Sales Ideas in Pictures	65
How Outstanding Radio Programs Are Being Merchandised	66
Striking Displays that Stopped 'Em	70
Sales Letters that Carry a Unique Personal Appeal	71
Your Editors Have This to Say	72
New Radio Products for the Dealer to Sell	74-78
What the Trade Is Talking About	79
News of Jobbers and Distributors	82
New Dealer Helps the Manufacturers Offer Merchandising Radio Parts	83
Review of New Circuits	87
New Radio Parts Announced This Month	91
	93

Mr. McGraw's Publishing Ideals

From an address by Edward J. Mehren at the dinner in honor of James H. McGraw, president of the McGraw-Hill Publishing Co., Inc., Hotel Astor, New York City, Dec. 17, 1926.

MR. MCGRAW holds before us three purposes of the business press. First, to be a collector and distributor of information; second, an interpreter of events and trends in our industry; and, third, a promoter of sound thought, a leader in the formulation of sound policy.

What are the principles Mr. McGraw has followed, what are the qualities he has brought to bear on his work?

The principles are many. The few I shall have time to mention can be summed up under one head, namely, his insistence upon the production of a very superior product.

The qualities similarly can be put into one group, and consist of an ardent spirit of service, of faith, vision, courage and perseverance.

HONESTY and accuracy are taken for granted, and I can assure you that lapses from accuracy, when they occur, are followed by mental thunderclaps. Always there is in him an intense desire for improvement. No issue of a magazine, no book, no accomplishment of a month or a year is ever satisfactory. I should say that he has a large collection of standards of dissatisfaction. Meticulous as to detail, he insists that every feature of the work shall be of pre-eminent quality, of "Tiffany finish," as he frequently expresses it.

Finally, these principles of the production of a superior product, these qualities of service, of faith, vision, courage and perseverance, are made effective by untiring application. He has a saying that "the man who would succeed must pay the price in hard work and sacrifice." He himself is the best example in the institution of hard, intelligent work, and sacrifice for an objective.

Member Audit Bureau of Circulations

Circulation of This Issue, 30,000 Copies

McGRAW-HILL PUBLISHING COMPANY, INC., Tenth Ave. at 36th St., New York, N. Y.

JAMES H. MCGRAW, President
JAMES H. MCGRAW, JR., Vice-Pres. and Treas.
MALCOLM MUIR, Vice-President
EDWARD J. MEHREN, Vice-President
MASON BRITTON, Vice-President
EDGAR KOBAK, Vice-President
C. H. THOMPSON, Secretary

Electrical World Journal of Electricity Ingenieria Internacional
Industrial Engineer Engineering and Mining Journal
Chemical & Metallurgical Engineering American Machinist
Electrical Merchandising Power Electric Railway Journal
Bus Transportation Engineering News-Record
Coal Age Successful Methods
Copyright, 1927, by McGraw-Hill Publishing Company, Inc.
Cable Address: "Machinist, N. Y."
Annual subscription rate is \$2 in United States and Canada.

WASHINGTON, D. C., Colorado Bldg.
CHICAGO, 7 South Dearborn St.
PHILADELPHIA, 1600 Arch St.
CLEVELAND, Guardian Bldg.
ST. LOUIS, Bell Telephone Bldg.
SAN FRANCISCO, 883 Mission Street
LONDON, E. C., 8 Bouverie St.

"Why Didn't I Make Money Selling Radio Last Year?"

A merchandising executive analyzes Jim Robinson's business statement for 1926 and points out its weaknesses —Also its promise of profits in 1927

Dear Jim:

YESTERDAY, I received your letter and the statement of your merchandising operation which was enclosed with it.

I am mighty glad to have the opportunity of studying this statement and passing on to you my comments thereon. I sincerely hope that they may prove of some value to you in the solution of your problems.

Now I am going to surprise you. It is evident from your letter that

you are quite discouraged at "worrying and working like a slave all year and ending up \$220 poorer" than when you started. Instead of feeling discouraged, I believe you have reason to feel very much *encouraged* at this showing, and before taking up those portions of the statement which I want to criticize for you, I will point out to you the favorable conditions.

The first year in business is always a critical one and, under normal con-

ditions, it is difficult to make a profit, but do not overlook the fact that during this period you are building up what should prove to be your most valuable asset, *prestige*.

A Turnover of Five Times

You started your radio business October 1, 1925 and, according to your statement, you had a retail stock at that time of \$9,384. During the year your retail sales amounted to \$40,901, and you ended up on

Sales, Operating Costs and Profit-and-Loss for Jim's

	No. 1—Sales				No. 2—Merchandise Costs								
	A Gross Sales	B Less Returns and Allowance	C Net Merchandise Sales	D Per Cent	E Invoice Cost of Purchases	F Less Cash Discount Earned	G Plus Freight Exp. and Cartage In	H Cost of Merchandise "Laid Down"	I Price of Merchandise at Retail	J Mark Up	K Mark-Up Per Cent on Retail	L Cost in Per Cent	M Average Cost of Merchandise Sold
Inventory.....								\$6,128	\$9,384	\$3,256			
OCTOBER.....	\$5,131	\$589	\$4,542	100	\$5,116	\$101	\$74	5,089	7,917	2,828			
To date.....								11,217	17,301	6,084	35.1	64.9	\$2,948
NOVEMBER.....	6,470	622	5,848	100	6,840	128	92	6,804	10,765	3,961			
To date.....								18,021	28,066	10,045	35.7	64.3	3,760
DECEMBER.....	11,862	755	11,107	100	2,160	41	26	2,145	3,309	1,164			
To date.....								20,166	31,375	11,209	35.7	64.3	7,142
JANUARY.....	4,318	665	3,653	100	987	19	17	985	1,521	536			
To date.....								21,151	32,896	11,745	35.6	64.4	2,352
FEBRUARY.....	3,954	343	3,611	100	1,624	31	34	1,627	2,616	989			
To date.....								22,778	35,512	12,734	35.8	64.2	2,318
MARCH.....	3,287	396	2,891	100	1,358	29	21	1,350	2,207	857			
To date.....								24,128	37,719	13,591	36.0	64.0	1,850
APRIL.....	2,198	186	2,012	100	1,041	21	24	1,044	1,617	573			
To date.....								25,172	39,336	14,164	36.0	64.0	1,288
MAY.....	1,802	148	1,654	100	1,020	19	18	1,019	1,592	573			
To date.....								26,191	40,928	14,737	36.0	64.0	1,058
JUNE.....	1,751	194	1,557	100	1,268	26	19	1,261	2,040	779			
To date.....								27,452	42,968	15,516	36.0	64.0	996
JULY.....	1,377	161	1,216	100	612	12	10	610	885	275			
To date.....								28,062	43,853	15,791	36.0	64.0	778
AUGUST.....	896	92	804	100	566	11	11	566	841	275			
To date.....								28,628	44,694	16,066	35.9	64.1	515
SEPTEMBER.....	2,110	104	2,006	100	2,674	54	48	2,668	4,310	1,642			
To date.....	45,156	4,255	40,901	100	25,266	492	394	31,296	49,004	17,708	36.1	63.9	1,282
Inventory.....								5,009	8,103	3,094			

A personal letter from S. J. Ryan to a friend in the radio business, showing him how to turn his losses of 1926 to profit during the current year.



October 1, 1926 with a retail stock of \$8,103. Your highest stock was \$17,676 on December 1—where it should have been—and dividing your average monthly retail stocks into your annual retail sales, we find that you secured a stock turnover of practically five times. From a figure viewpoint, this is good merchandising and the only question is whether or not your retail stock at the end of the period consists of new,

Radio Business That Did \$40,901 Last Year

No. 3—Cost of Doing Business										No. 4—Profit-or-Loss					
Occupancy Expense		Selling Expense		Publicity Expense		Administrative Expense		Other Costs Expense		Total Expenses		Gross Margin on Sales	Net Profit on Sales		
Dollars	Per Cent	Dollars	Per Cent	Dollars	Per Cent	Dollars	Per Cent	Dollars	Per Cent	Dollars	Per Cent			U	V
N		O		P		Q		R		S	T				
.....	Inventory
\$161	\$635	\$210	\$382	\$27	\$1,415	31.1	\$1,594	\$179	OCTOBER	
.....	To date	
168	687	316	418	18	1,607	27.5	2,088	481	NOVEMBER	
.....	To date	
164	812	440	454	31	1,901	17.1	3,965	2,064	DECEMBER	
.....	To date	
159	570	186	396	194	1,505	41.2	1,301	-204	JANUARY	
.....	To date	
158	528	142	310	16	1,154	32.0	1,293	139	FEBRUARY	
.....	To date	
156	481	121	251	372	1,381	47.9	1,041	-340	MARCH	
.....	To date	
155	439	115	238	23	970	43.2	724	-246	APRIL	
.....	To date	
153	415	108	231	14	921	55.6	596	-325	MAY	
.....	To date	
153	412	90	223	15	893	57.3	561	-332	JUNE	
.....	To date	
152	416	63	229	29	889	73.1	438	-451	JULY	
.....	To date	
152	421	81	230	34	918	114.2	289	-629	AUGUST	
.....	To date	
156	494	197	265	168	1,280	63.8	724	-556	SEPTEMBER	
1,887	4.6	6,310	15.4	2,069	4.9	3,627	9.0	941	2.3	14,834	36.2	14,614	-220	To date	
.....	Inventory	

salable merchandise, or of slow moving, obsolete goods. If it is the latter, of course your inventory is not worth its book value by any means, and a depreciation will be in order. This will tend to increase your loss on the year's operations.

Another point upon which I desire to comment favorably is the gross margin of profit which you have obtained. Observing this and also your transportation charges, it is evident that during the slack months you filled in your stock with whatever you needed from your local jobbers. This is good merchandising practice, even though the discount may be a little shorter. The mark-up, or gross margin, which you maintain on the year's operations is all that could be expected. As your business grows in volume, this can be increased 3 per cent to 4 per cent, but under the conditions I think that it is very satisfactory.

The returns and allowances do not appear to be excessive. In fact, I would say that they were less than the average, because it is frequently necessary to send radio merchandise out on a trial basis. You have apparently been careful to earn your cash discounts.

Your merchandising operation as a whole looks very favorable, and it is evident that you have given a

great deal of thought and work to it. Let us now consider the costs of doing business.

N—Occupancy. In view of the fact that you are paying a rental of \$150 a month, one cannot quarrel with your total "occupancy expense" of \$1,887 for the year, although this percentage of 4.6 per cent takes a big bite out of any possible profit. It is hardly fair, however, to criticize occupancy charges in the first year's operation. If this continues during the present year, it seems to me you will have to find some means of increasing your volume in order to reduce this percentage. Occupancy should not be over 3 per cent to 3.5 per cent of retail sales.

O—Selling. High. Of course, this includes salesmen's salaries, delivery expense, service department costs, and all supplies used in selling and delivering. But still it is high; especially in spots. The margin between operating your business at a profit and loss, namely \$220, is so small that I believe I see several places where this money could have been saved. For example, in the month of August, when you sold only \$804 at retail, the selling expense amounted to \$421. In the month of July, with sales of \$1,621, your selling expense was \$416. In other words, your selling expense during

these two months was actually a few dollars higher than in the months of May and June, when your sales were more than 50 per cent greater. From these figures, it is apparent that you cut your selling expense, beginning with April, to as low a figure as you thought you could get along on. This is a mistake. You knew what you were up against, especially in the months of July and August, and I believe that from May 1 to September 1, at least, you could have got along with the services of one less person. This in itself would have covered your loss for the year.

P—Publicity. It would be a dangerous thing to attempt to criticize this item, although its percentage of 4.9 might be a trifle high. I believe, however, you used good judgment here, because you must establish yourself, and I think a publicity charge of not exceeding 5 per cent is good business, especially for the first few years.

Q—Administration. Unquestionably this percentage of 9.0 is high. Invariably we find this condition in small businesses—high administrative expense. In this division of expense we include your salary, the salary of office employees, telephone, printing, postage, and miscellaneous office supplies. When we take all this into consideration, the total amount

Jim Robinson's Merchandise Sales, Gross Margin, and Net Profit and Loss by Months (right).

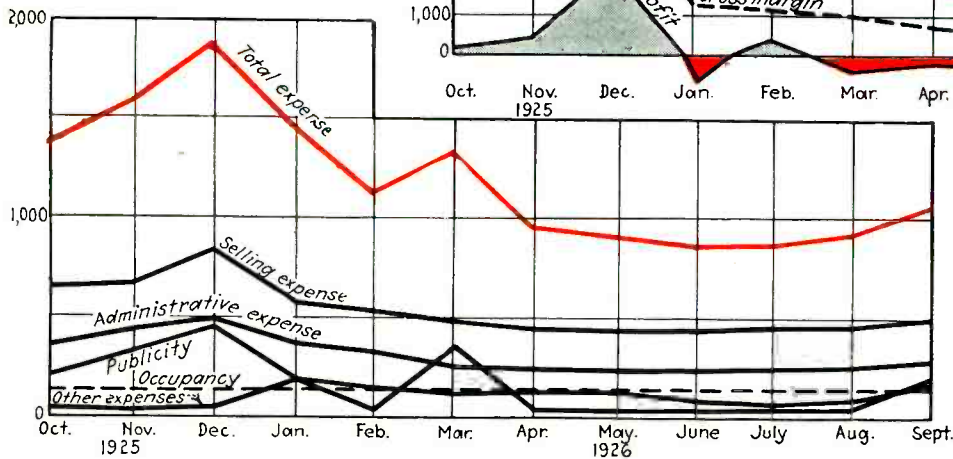
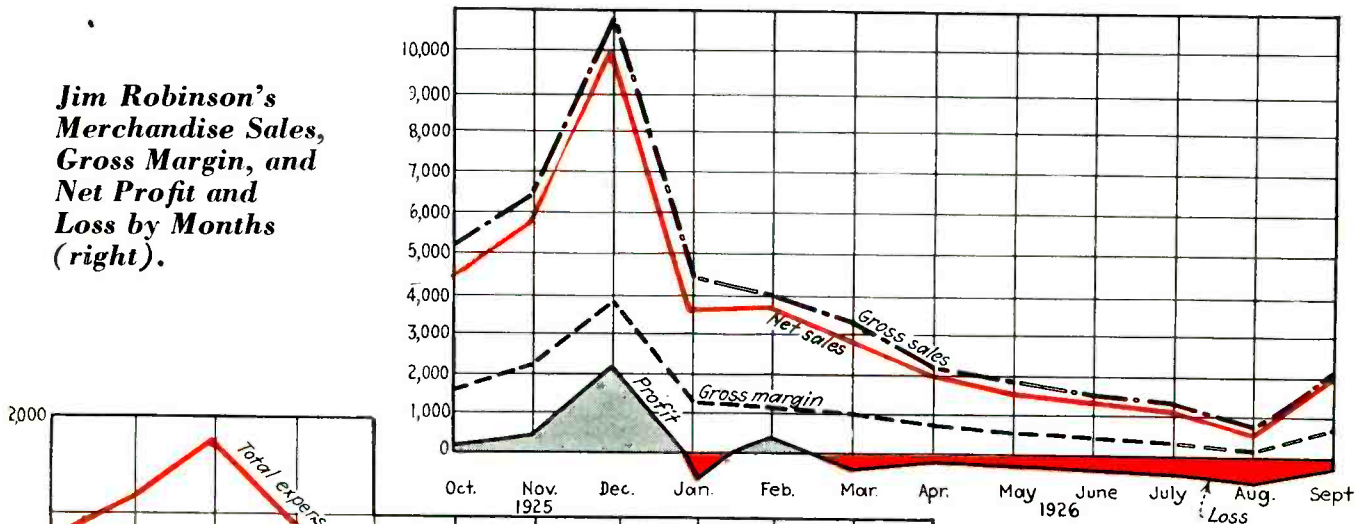

Jim Robinson's Store Operating Expenses by Months (left).

of \$3,627 for the year does not appear bad.

You state you are paying yourself a salary of \$50 a week, and unquestionably you are earning that. This leaves about \$20 a week for everything else. In looking over the figures in this column by months, it is difficult to pick out any particular weakness. It is simply a common case of where the business is not large enough to stand these fixed charges. Consequently the percentage mounts. You might, with a practice of strictest economy, have saved a couple of hundred dollars, but that is rather difficult for me to say.

R—Other Costs. This column appears all right. The bulges in the months of January, March and September are undoubtedly due to tax requirements, as this column includes taxes, depreciation, interest, insurance, and any other expense which cannot be allocated to the other divisions. The percentage of 2.3 is normal.

Volume Is Important Factor

Your monthly cost of doing business varies from 17.1 per cent in the month of December to 114.2 per cent in the month of August, showing conclusively what a powerful factor is volume. Your expenses varied as well, but not nearly in proportion, with a low of \$893 in the month of June, and a high of \$1901 in the month of December. You made profit in the months of October, November, December and February, and should have made a profit in the month of January. During the remaining months of the year you operated at a loss.

For the coming year, I would, by all means, concentrate on those months where you had a *small loss* during 1926. Do not worry so much about July and August right now, but make up your mind to make a profit in January, March April, May and June. If you do this, the rest of the year will take care of itself.

Combining January and February's operations, you showed a loss for the two months of \$65, whereas you should have made a profit in both months.

What I would do in February is to *budget my expenses* right now on the basis of last year's business. In 1926 it cost you 41.2 per cent to do business in January and 32.0 per cent in February. Retrenchment this year would have to come in selling, pub-

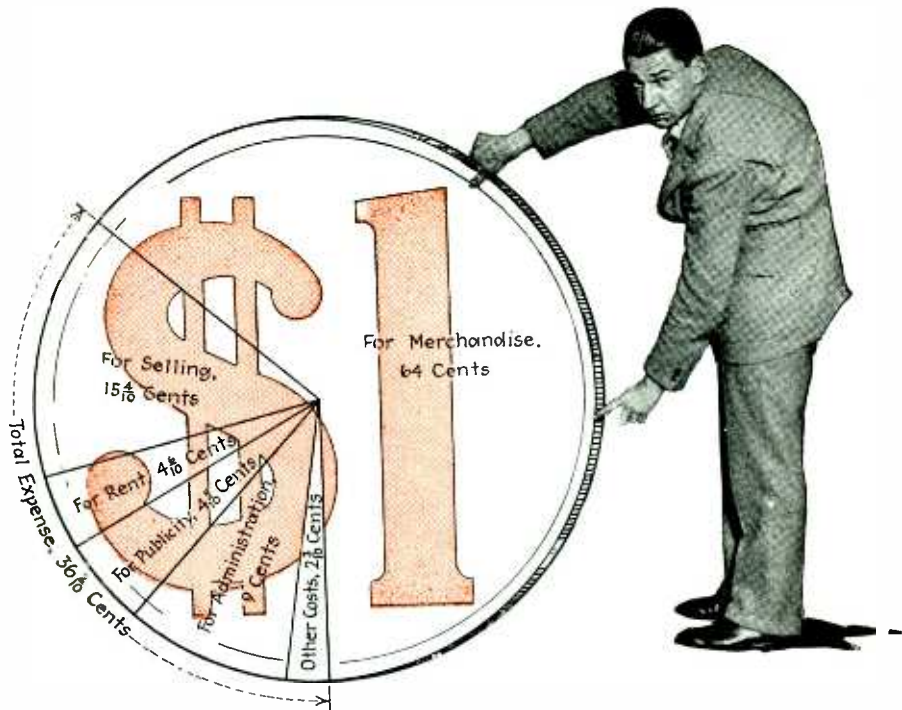

**Where Jim Robinson's
1926 Expense Dollar Went**

licity, and administration. Some from each, because you cannot reduce occupancy or taxes. Of course, if you can secure a gradually increased volume, everything will be all right, but do not figure on that in advance and go out and contract expenses against it, because in the event that you do not get it, you will put yourself in the hole.

Obviously, speaking of the operation as a whole, you must either reduce your expenses or increase your volume *without a corresponding increase in expense*. Probably the best way to accomplish this would be to attempt to handle some other line of merchandise in addition to radio during the months of May, June, July and August, at least, but it should be done on a basis whereby you would

have little or no stock investment, and it would be unnecessary to expand your organization or increase your expenses in any other way. Otherwise, you would be no better off than you are at the present time with a straight radio set-up.

I note your comments regarding how helpful this form has proved, and I am certain that its continued use will prove very valuable to you in guiding your business.

What a wonderful help it would be to you, and to other radio dealers, if you could have the detailed figures of their businesses worked out on a form like this, so that you could compare them with your own!

Faithfully Yours,
S. J. RYAN.

How to Make Your Business Pay

Maintain a mark-up or gross margin of at least 35 per cent.

Fill in stock during dull season from local jobber.

Take advantage of your cash discounts.

Occupancy costs should not exceed 3 to 3 1/2 per cent of total retail sales.

Administration expenses

should be kept as low as possible.

Publicity should not exceed 5 per cent of sales.

Budget your expenses in February on the basis of last year's business.

Have a side line from May to September—but with little or no stock investment.

The 1927-1928 Trends in

ACCORDING to present indications, the new radio sets for the season 1927-28 will embody no radical changes, either in circuit or cabinet design, over current lines. Rather there will be minor improvements designed to increase the saleability of the sets.

Manufacturers agree that simplicity of control is a necessity and, accordingly, most sets planned for the season to come will be limited to two tuning controls. Three-dial control is rapidly losing ground and single-control cannot always be reconciled to electrical efficiency. Although successful single-control sets will undoubtedly be marketed, many manufacturers are compromising on the two-dial system as the most desirable.

Drum-type controls and dials of the window-type also seem to be finding increasing favor. Few manufacturers, at this time, are adhering to the old-style large round dials. The trend, in this direction, is to make the tuning elements as inconspicuous and attractive as possible.

Shielding will also play an important part in next season's sets although there is a sharp difference of opinion between manufacturers as to the advantages of shielding. Manufacturers of totally shielded receivers maintain that their sets are greatly improved thereby, while other manufacturers claim shielding is a waste of money and that if the sets were properly designed there would be no need of shielding. One manufacturer specifically states his sets will not be shielded next year and makes the claim that shielding absorbs energy and that an extra tube must be added to overcome this defect. This leads to the conclusion that, while shielding will continue to be popular next season, it may be possible that unshielded sets will sell as well, and give as good results, as shielded receivers.

It is a well known fact that socket power devices have not always been sensationally successful commer-

cially, owing to the difficulty of designing units that would work efficiently on all types of circuits. The trend in this direction will inevitably be, engineers state, to design socket power instruments specifically for certain sets, or to build the unit in the cabinet as an integral part of the receiver, each constructed to meet the particular needs of the other.

There will be no radical changes in the design of receiving circuits this year, either, according to some of the leading radio engineers, unless some radical change is made in the design of vacuum tubes which would necessitate a corresponding change in circuits. While it is generally known that tube design has not been perfected and that changes are on the way, it has been definitely announced by the leading tube manufacturers that such changes, if they come this year, will come so late in the season that no market disruption will occur. The trade is therefore proceeding with plans for the new season with full confidence that radical revolutions will not affect this year's business.

Important improvements in tubes can undoubtedly be looked for within



the next twelve months, particularly in the field of 110-volt tubes, which, of course, will require radically new circuits. But this tube is not yet ready for marketing and will not be ready for some time to come. Manufacturers without exception have notified us that they are proceeding with their present lines practically unchanged.

In fact, the question uppermost in manufacturers' minds at this time is cabinet design rather than circuit design. Circuit design depends on new tubes and until new tubes are forthcoming, why worry about it? In the matter of cabinet design, however, there seems to be a hot controversy raging as to the logical place for the loud speaker.

The question of the moment which is agitating "radio architects" is: "Shall or shall not the loud speaker be removed from the cabinet?"

Where to Put the Speaker?

In several instances, leading manufacturers are committed to a definite policy of complete separation of the speaker from the set in all models, whether or not the console is large enough to accommodate the speaker. Manufacturers adhering to this trend in cabinet design state it is electrically wrong to place the speaker in close proximity to the circuit and they will not make and sell instruments which they know to be electrically wrong in spite of an apparent public demand for a complete unit.

Is the Era of Radical Changes Over?

Manufacturers' lines, this year, remain practically the same. No radical changes are planned for the immediate future. Minor changes and improvements are apparent and manufacturers are devoting much attention to cabinet design. Where to put the loud speaker is a question in the solving of which the retail trade is asked to help.

Cabinet and Circuit Designs

"Where to put the reproducer" is a puzzle confronting those who design receivers—Shall it be separated from the set or continued as part of the console? Question of 110-volt tube discussed.



The electrical reason for this separation is that when the speaker is near the circuit, the air vibrations set up by the speaker travel to the set and put the elements inside the tubes into vibration, resulting in howling and other noises. Mechanical shielding has little or no effect in diverting these sound waves, but, while they cannot be wholly eliminated, it has been found they can be dampened somewhat in several ways. These include weighing the tube down with a rubber or metal cap, or placing the loud speaker on shock-absorbing cushions. Sometimes, it will also be found, in placing the speaker unit too near the set, that a magnetic coupling is set up between the fields of the various units which tends to create a distinct howling.

Reception Said to be Improved by Separation of Speaker

For these reasons, and because the vibrations cannot be eliminated altogether, manufacturers who stand firmly for the divorce of the set and speaker maintain better reception can be obtained by the separation and that the public will accept their radio sets in two units when they are convinced that reception will be improved.

On the other hand, engineers of manufacturers who are placing the loud speaker inside the console with little or no detrimental effect apparent, put forth the assertion that the vibrations can be satisfactorily overcome and that to separate the set and speaker is an admission of weakness in circuit design.

These manufacturers state that the public demands a complete console and that therefore they should have it. And if the speaker can be incorporated in the console and still give good reception, why change?

There is still another group of manufacturers who are between the devil and the deep sea about it. They are asking themselves whether to put the loud speaker inside the console next season and if not, will the public accept a console containing only the set and batteries, with an external speaker which can be moved about and placed in any part of the room?

Retail Trade Can Help

Right here is where the retail trade can help to solve this perplexing puzzle in cabinet construction. What do dealers think about it? How do their customers feel about it? Dealers can perform a great service for manufacturers if they will find out from their customers whether or not consoles with an external speaker would be readily sellable, and write the results of their inquiries to the editors of *Radio Retailing*.

There are many men in the trade who believe a large part of the public would not be averse to a separate speaker, which may be placed in that part of the room where acoustical conditions required that it be placed most advantageously, which may be a spot far removed from the receiver itself.

The separate speaker idea would also simplify the "radio in every room" plan, giving the set owner the opportunity to place the set in an

out-of-the-way nook, and have several speakers in other rooms, or carry the speaker to whatever location in the house where reception was desired, obviously impossible when the speaker is built in the cabinet. Many houses are now being built with a special nook off the living-room for the radio set, permitting the speaker to be placed wherever desired.

Trend Toward Separation?

In spite of this controversy, and in spite of the desire on the part of many manufacturers to continue the console model complete in itself, there seems to be a growing movement toward dividing the receiver into two units—the detector circuit in one unit and the amplifying system in another unit, or other lines of demarcation.

Several companies have already

Please turn to page 64

Advertising—Making Every Dollar Bring in 15 More

Montalvo credits a 78 per cent increase in radio sales in a single year to an additional 70 per cent investment in advertising. He schedules his advertising appropriation on business desired rather than on business done, yet his expenditure does not exceed 6.8 per cent of total sales

DOES your advertising pay?" "How do you know it does?" Asked point-blank, these are difficult questions for any retailer to answer.

Ordinarily, the radio dealer who spends upwards of 5 per cent of his gross sales for advertising will answer in the affirmative to the first

question, then grapple helplessly with the second. He *knows* it pays, but he can't prove it!

Then again there is a type of retailer who wants firsthand information on his advertising. He not only wants to know definitely if it does pay but also how much. R. Montalvo, owner and manager of Montalvo's

Temple of Music, New Brunswick, N. J., is one of these dealers.

Late in 1925 Montalvo set out to make sure his advertising paid. Although he was morally certain that the value of advertising was cumulative rather than immediate, he collected and itemized advertising bills and segregated radio sales from the balance of his music business in the belief that an accurate picture of sales fluctuations in relation to advertising expenditures over an entire year would furnish a sounder basis for his 1926 appropriation.

Checking Up On '25

At the end of 1925 the character of his advertising in relation to sales was plainly indicated by a comparison of the black lines indicated on Graph "A." The curves traced on this graph were plotted from his actual figures for the entire year.

Tracing the dotted black line, representing his monthly advertising expenditure, then comparing its fluctuations with the sales curve for the same period, reproduced as a solid black line in the same graph, shows that the sales line closely follows the advertising line.

In January, 1925, for instance, his sales reached \$2,925. His advertising expenditure for the month was \$214. February showed a slight advertising decrease and a proportionate drop in sales. In March, advertising and sales went still lower. The sales line reached its low level in July and advertising in August. Both followed the down-trail from the first of the year to mid-summer. Throughout this period the curves were very similar, although his procedure in apportioning advertising during this time had been more or less haphazard.

June was the single exception. During this month Montalvo's advertising outlay had been high though no sales response was forthcoming. Possibly during this month

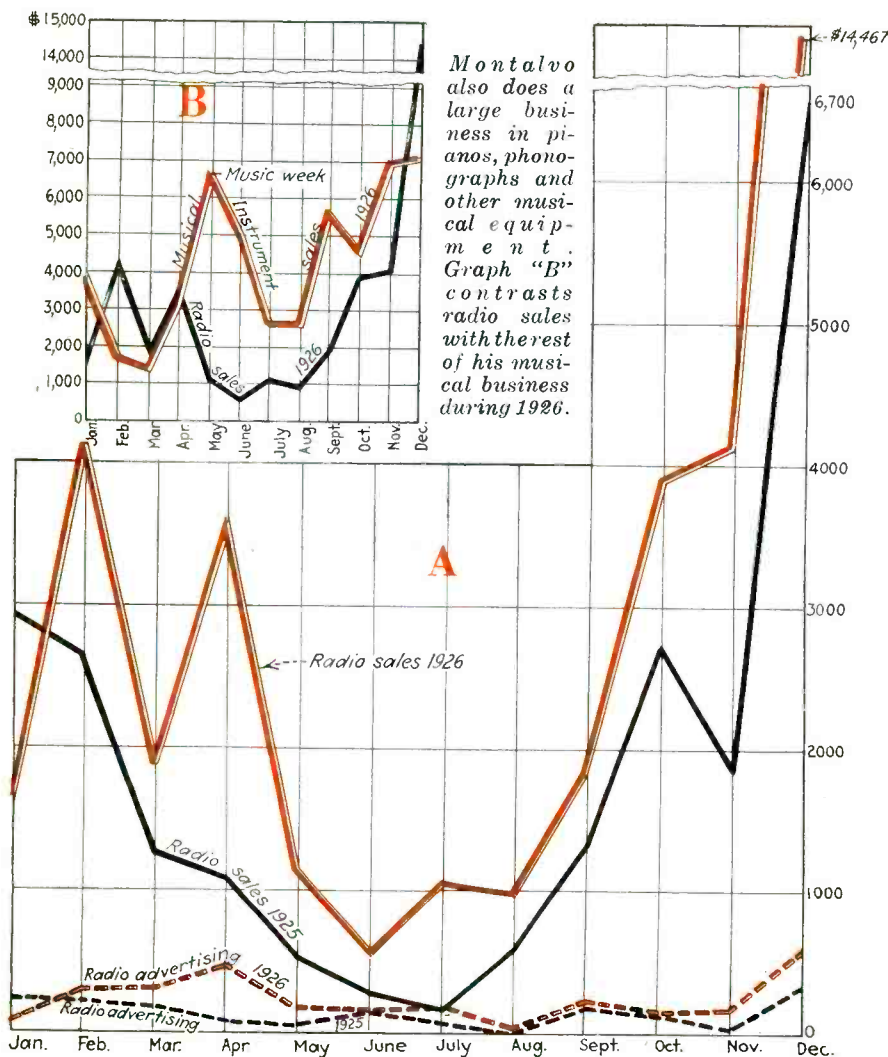

Montalvo also does a large business in pianos, phonographs and other musical equipment. Graph "B" contrasts radio sales with the rest of his musical business during 1926.

Montalvo's advertising expenditure from January to December, 1925-1926, is compared in this chart with his radio sales for the same period. The dotted black line represents advertising for 1925 while

the solid black line is plotted from his monthly gross sales for this year. The dotted red line represents 1926 advertising expenses contrasted with gross sales for this period, indicated by solid red line.



Dealers Who Have Made Radio Pay No. 2

the copy had not been effective—perhaps its effect was not felt until the following month when sales began the steady ascent to December's peak.

September's increased advertising expenditure added impetus to October sales, carrying them to approximately the January sales level. October's expenditure remained practically the same, but sales mounted in accord with the regular seasonal demand. In November the striking similarity of the advertising and sales curves again became apparent. Advertising had been permitted to drop to \$33. Sales dropped nearly a thousand dollars.

Examination of sales and advertising totals indicated that publicity represented 7.1 per cent of total sales for 1925.

All this proved to Montalvo that there was a definite tie-up between advertising and sales. Gross business had more or less followed his advertising efforts during the entire year.

Of course a seasonal demand for radio was apparent. Sales had naturally decreased during the summer months and probably no permissible amount of advertising could raise the line during this period. There had been seasonal demands for other musical apparatus, particularly noticeable during July and August.

Unless he could be reasonably certain of proportionately increased sales he could not rightfully afford to increase his advertising budget in proportion to these same gross sales. The business could not permit ad-

vertising to run higher than 7 per cent of sales.

But why could not the advertising outlay be increased, depending on it to increase sales and thus reduce its proportion in relation to gross sales? Why not base 1926's advertising budget on the desired business rather than on the business of the previous year?

Sales had followed advertising during 1925 rather than the "other way 'round." Advertising had influenced sales during the year when Montalvo's budget was planned merely as an item "not to exceed 7 per cent of total sales."

What Happened in '26

Accordingly Montalvo proceeded to plan his 1926 advertising budget on this basis of *desired* sales. During 1925 his radio business, aside from his piano and phonograph business, had grossed \$22,036. The town was capable of buying at least \$35,000 worth of radio sets from him during the year. His sales equipment, service department and office facilities were more than adequate to take care of this extra business. So 1926's advertising budget was based on the assumption that he would do \$35,000 worth of radio business that year.

Assuming that advertising costs could not safely exceed 7 per cent of

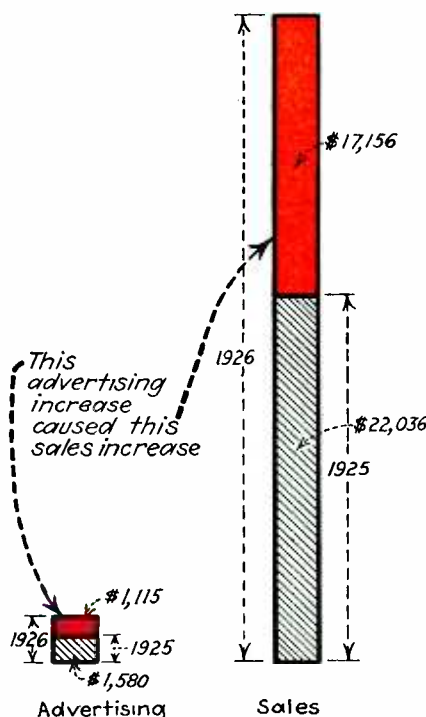

The proportionate increase in Montalvo's radio business during the year 1926, responding to an increase in radio advertising during the year is graphically illustrated in this comparison drawn to scale.

\$35,000, his expected gross business, he budgeted his total expenditure for advertising purposes of all kinds as \$2,500.

A comparison of the two red lines in Graph "A" proves conclusively that advertising during 1926 did pay on this basis—that it was actually responsible for a good deal of his business. The prospects brought to his store through advertising were enough of an influence to affect his sales curve.

The dotted red line in Graph "A" represents the advertising expense during 1926 while the solid red line represents sales during this period. Note how the peaks in the sales line follow closely after the peaks in the advertising line.

1926 Sales 77.8 Per Cent Greater

First of all Montalvo's radio business during the year 1926 was \$39,192, exceeding 1925 by \$17,155, approximately a 78 per cent increase. During this period he had spent the allotted \$2,500 and more, bringing the advertising total for the year up to \$2,695, or 6.8% of the radio sales.

It was apparent that he had increased his business to such an extent by actually inflating the advertising budget by more than \$1,000, as to reduce the appropriation from 7.1 to 6.8 per cent of annual sales. He had spent more but had more than made up for it by greatly increasing his sales. He had made every advertising dollar produce \$15 more in sales.

Comparing the 1925 and 1926 sales curves it is seen that his increased advertising budget had little appreciable effect on the character of the year's business in so far as periods of natural depression were concerned. The decrease during June, July and August was still apparent but the entire sales curve had been raised hundreds of dollars all along the line!

January, 1926, business fell below that of 1925. Poor judgment at this time led to a reduction of advertising to a lower level than that of the same month the preceding year, with a resultant drop in sales to a correspondingly lower level. Advertising and sales throughout the balance of the year stayed considerably above 1925's curve.

The immediate comeback of sales when advertising pressure was renewed in February may be noted. March dropped back several thousand dollars, paralleling the 1925 decrease despite increased advertising, due to general business depression. April sales mounted as a result of an advertising expenditure far in excess of the previous year. From that month on advertising and sales retained their normal relation, with sales running considerably higher than in 1925.

Although Montalvo has employed direct-mail, he finds newspaper advertising more effective in his territory. Circulars are occasionally forwarded to his prospect list, but the list itself has largely been compiled from prospects originally brought to

the store through newspaper advertising.

Forty per cent or more of the prospects entering the store in response to "ads" are later sold. Montalvo's policy is to waste little time mailing circulars but immediately to have his "closer" make a personal call if the sale is not closed in the store.

Reliable merchandise, service and honest values are his sales features. Therefore every "ad" stresses *Montalvo* and *Radio*. His copy is written primarily to advertise to New Brunswick the fact that he sells radio. Thus most of his successful "ads" have both his own name and the word *Radio* in bold face type.

As will be noticed from Montalvo's advertising curve, he believes in continuing his radio advertising in some measure throughout the summer season. His efforts at this time are usually centered on his best selling lines on which sales resistance is low.

His experience in advertising brings one point to the fore. "Advertising pays—provided the proper sales and follow-up methods are employed to back it up," he states. "Advertising, much like house-to-house canvassing, should have as its chief function the securing of new prospects. Its object is not actually to bring sales to the closing point but to secure prospects—to get people to write or come to the store.

"Advertising itself is valuable, but the dealer who relies on it alone to make sales is deliberately throwing away its principal benefits."

Month	Radio Advertising		Radio Sales		*Total Advertising		*Total Sales	
	1925	1926	1925	1926	1925	1926	1925	1926
January	\$214.65	\$54.60	\$2,925.82	\$1,589.47	\$533.70	\$103.50	\$14,040.37	\$5,764.50
February	210.75	273.15	2,631.15	4,140.79	481.54	485.17	10,595.91	5,683.54
March	179.02	291.00	1,260.90	1,878.93	414.85	641.50	11,489.34	3,204.75
April	90.60	456.15	1,077.30	3,552.07	204.87	1,292.17	5,935.03	6,738.52
May	43.75	167.10	512.77	1,115.68	118.57	389.77	4,376.53	7,759.45
June	111.00	147.00	270.75	547.42	283.42	69.231	3,436.59	5,554.53
July	77.02	157.12	153.15	1,056.07	182.05	422.85	3,604.44	3,738.09
August		27.00	589.12	975.00		40.50	3,153.63	3,670.41
September	186.00	217.95	1,309.57	1,841.55	723.37	482.50	11,295.84	7,227.93
October	120.00	139.50	2,704.90	3,895.35	233.44	151.17	4,072.26	8,571.21
November	33.15	187.65	1,873.95	4,132.81	79.12	224.83	4,704.91	10,941.85
December	315.00	577.50	6,718.53	14,467.02	1,186.86	1,339.32	9,074.74	21,527.67
TOTAL	\$1,580.94	\$2,695.72	\$22,036.91	\$39,192.16	\$4,441.79	\$6,265.59	\$85,779.59	\$90,382.45
Per cent of increase		70.5		77.8		41		5.3

*Radio, Phonographs, Pianos and Musical Supplies.

From this basic study of his business, Montalvo arrived at figures permitting the compilation of the graphs used with this article. In the two main columns at the left of the sheet, radio advertising and sales for 1925 and 1926 are listed in this order. The two columns to the right represent his total business which

includes radio. Advertising and sales expenses for his radio business, or total business for either 1925 or 1926 may thus be found by merely referring to the totals at the bottom. Month by month and year by year these same figures are available by merely tracing from the desired month and year headings at the extreme left.

He Made Service Pay!

When Price-Cutting Failed—

An ex-price-cutter tells how he put business on a firm financial basis

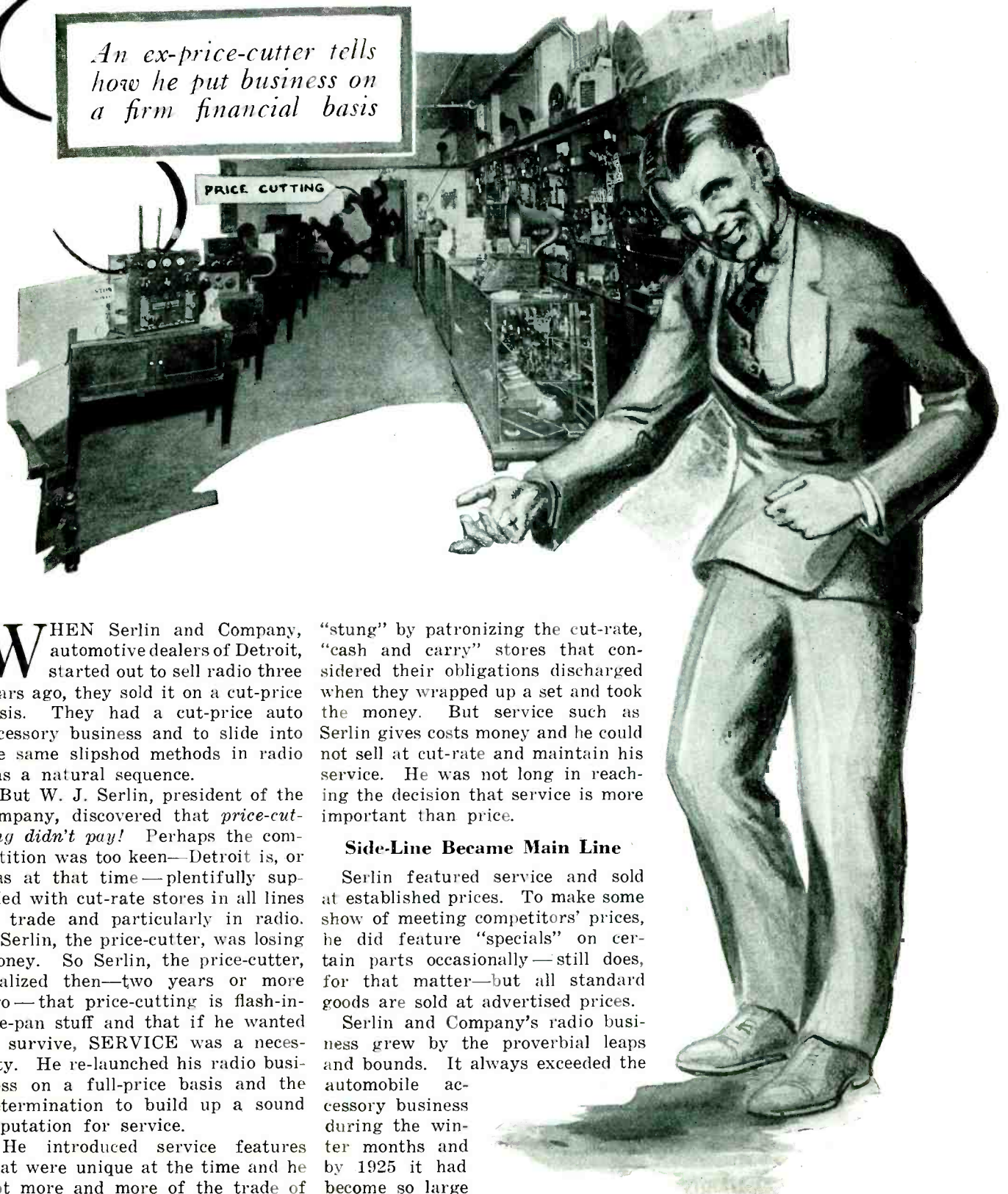

WHEN Serlin and Company, automotive dealers of Detroit, started out to sell radio three years ago, they sold it on a cut-price basis. They had a cut-price auto accessory business and to slide into the same slipshod methods in radio was a natural sequence.

But W. J. Serlin, president of the company, discovered that *price-cutting didn't pay!* Perhaps the competition was too keen—Detroit is, or was at that time—plentifully supplied with cut-rate stores in all lines of trade and particularly in radio.

Serlin, the price-cutter, was losing money. So Serlin, the price-cutter, realized then—two years or more ago—that price-cutting is flash-in-the-pan stuff and that if he wanted to survive, SERVICE was a necessity. He re-launched his radio business on a full-price basis and the determination to build up a sound reputation for service.

He introduced service features that were unique at the time and he got more and more of the trade of radio enthusiasts who had been

“stung” by patronizing the cut-rate, “cash and carry” stores that considered their obligations discharged when they wrapped up a set and took the money. But service such as Serlin gives costs money and he could not sell at cut-rate and maintain his service. He was not long in reaching the decision that service is more important than price.

Side-Line Became Main Line

Serlin featured service and sold at established prices. To make some show of meeting competitors' prices, he did feature “specials” on certain parts occasionally—still does, for that matter—but all standard goods are sold at advertised prices.

Serlin and Company's radio business grew by the proverbial leaps and bounds. It always exceeded the automobile accessory business during the winter months and by 1925 it had become so large that it actually

<p align="center">SERLIN & CO. SERVICE INSURANCE POLICY</p> <p>By this Service Policy, Serlin & Company, a Michigan Corporation, Detroit, guarantees to the purchaser of this</p> <p>No.</p> <p align="center">I.</p> <p>That this instrument is, to the best of our expert knowledge, free from all defects in material and workmanship.</p> <p>That the Serlin & Company will replace or repair FREE OF CHARGE any part or parts which prove to be defective.</p> <p>This guarantee, however, does not apply to any instrument which our examination and expert judgment shows to have been subject to misuse, neglect or accident, nor any instrument which has been subject to alterations or repairs by anyone except Serlin & Company Radio Engineers, which in our judgment affects its stability or reliability.</p> <p align="center">II.</p> <p>That Serlin & Company issues this instrument to the extent of the coupons attached to this policy.</p> <p>That the above service insurance shall consist of the adjustment and repair of receiver and equipment which in our judgment we deem necessary in order to correct all unsatisfactory conditions for which said receiver or equipment purchased from Serlin & Company is plainly responsible.</p> <p>That the above service shall be additional to the original installation of said instrument and shall not apply to aerial installation nor subsequent battery nor tube installations.</p> <p>That the above service shall be paid for by means of the coupons attached hereto, time to be computed from time of leaving our store and completion of service; or, for actual time consumed if instrument is brought to our Service Department by the purchaser.</p> <p align="center">SERLIN & COMPANY.</p> <p>By</p> <p>Service Policy No. //</p> <p>Issued To</p> <p>(SEAL) Expires</p>	<p align="center">SERLIN & COMPANY</p> <p>This Coupon will be accepted in full payment of one-half hour's service in accordance with the attached Policy No. Not good for materials. Void if detached. Not valid after</p> <hr/> <p align="center">SERLIN & COMPANY</p> <p>This Coupon will be accepted in full payment of one-half hour's service in accordance with the attached Policy No. Not good for materials. Void if detached. Not valid after</p> <hr/> <p align="center">SERLIN & COMPANY</p> <p>This Coupon will be accepted in full payment of one-half hour's service in accordance with the attached Policy No. Not good for materials. Void if detached. Not valid after</p> <hr/> <p align="center">SERLIN & COMPANY</p> <p>This Coupon will be accepted in full payment of one-half hour's service in accordance with the attached Policy No. Not good for materials. Void if detached. Not valid after</p> <hr/> <p align="center">SERLIN & COMPANY</p> <p>This Coupon will be accepted in full payment of one-half hour's service in accordance with the attached Policy No. Not good for materials. Void if detached. Not valid after</p> <hr/> <p align="center">SERLIN & COMPANY</p> <p>This Coupon will be accepted in full payment of one-half hour's service in accordance with the attached Policy No. Not good for materials. Void if detached. Not valid after</p>
---	---

With one masterly stroke Serlin offers prospects tangible evidence of his willingness to give adequate service after the sale and at the same time protects himself from the customer who expects unlimited free attention. He is one of a number of retailers who obtained the "Service Policy" idea from the December, 1925, issue of "Radio Retailing" and applied it profitably.

showed a bigger volume during the summer months, when automobile accessories are most in demand and radio is least in demand. During the radio season, the radio department ran as high as 600 per cent above the automobile accessory department.

The automobile accessory department was neglected, to a certain extent, in favor of radio. This was not as it should be, of course, so Serlin and Company sold out its auto department to others who would give their entire effort to it and continue to operate it under the Serlin name.

That was January 1, 1925. Relieved of the automobile accessory business, Serlin made a gain of approximately 33½ per cent for the year and maintained the same pace in 1926, in the face of competition that is featuring nationally advertised sets at prices ranging all the way from \$9.98 up.

The service which Serlin inaugurated several years ago, and which he believes essential to the proper conduct of such a business, includes a laboratory, where customers are privileged to come in and work on

their own sets, have their work done, or secure advice, and also a corps of outside service men who answer service calls promptly and efficiently.

The laboratory is located in the basement of the store and is completely equipped with electrical machines and tools of the most modern type. The man in charge formerly had been at the head of one of the largest broadcasting stations in the country and his assistant is a graduate electrical engineer who has specialized on radio ever since it became popular. Both men are radio enthusiasts and know how to sympathize with the radio "bugs" who besiege them with all manner of questions. They are prepared to explain all the hows, whys and wherefores of the subject patiently, simply, and intelligently. They are primarily service men and much of their time is occupied by giving advice, directing the work of amateurs who come in to use the laboratory, and making repairs on sets. They also build sets to order and do repair work on an hourly basis.

This service feature is capitalized

in the firm's advertising, practically every newspaper ad being prefaced by some comment on the importance of service. "Service goes hand-in-hand with Serlin," for example. Again—"With every purchase made here is the assurance of real helpful, expert advice—the kind that gives you confidence in yourself—and in this store. Bring in your set, complete or otherwise; have it checked up and tested by our experts at no cost to you. Completely equipped laboratory for the radio experimenter."

Another advertisement emphasizes the fact that: "A window full of radio doesn't make a radio store! Find out before you buy a radio set, or the parts to make one, whether the store to which you go offers anything more in the way of service than wrapping up your purchase and taking your money. With every purchase in our radio department there goes an assurance of expert advice always at your command. Our fully equipped experimental laboratory and staff of experts are maintained for the sole purpose of helping and advising our customers."

Mr. Serlin secured from this magazine last year the idea of giving service coupons with sets at the time of the sale and has incorporated it in his business. There is a service agreement, which is signed and stamped by the firm, and 18 coupons, each good for one hour of service. The service agreement and coupons are in the form of a folder and the perforated coupons may easily be detached. Two pages are detached, leaving only six coupons, when the sale is of an inexpensive set; one when the sale is of a medium-price set. All 18 coupons go with an expensive set. Paradoxically enough, though, the more expensive the set, the less service it is likely to require, and vice versa. When a service man answers a trouble call, he collects one or more of the coupons, depending on the amount of time he spends on the trip. The coupons are good for 90 days from date of sale.

Many of the service calls, as every dealer knows, are for ridiculous little things that are due to the owner's ignorance, but they must be taken care of, nevertheless.

Mr. Serlin finds that the demand for service is on the increase and he predicts that dealers are going to be compelled to give more service.

"When radio was new," he pointed out, "the majority of customers were

Please turn to page 59

Selling the Quality Market

"Radio Architect" did \$100,000 business in three years in a town of 9,000 by specializing in built-to-order cabinets and high grade sets

GREAT NECK, Long Island, is a town of 9,000. Located in a beautiful suburban section within commuting distance of New York and close to bathing beaches, its growth has been rapid. During the past five years property values have trebled. High grade shops line both sides of its main street. Ninety per cent of the homes are owned by residents.

In April, 1924, William Barrows, Jr., of Boston, Mass., decided to enter the radio business. After a preliminary survey of business conditions in several Eastern New York towns he opened a shop in Great Neck. In an 11 x 18 ft. shop he placed \$600 worth of radio apparatus, his entire stock. The monthly rental was \$30.

Today Barrows owns and operates the largest radio store in the town. His shop, located on the main street, occupies more than three times its original space and contains \$9,000 worth of

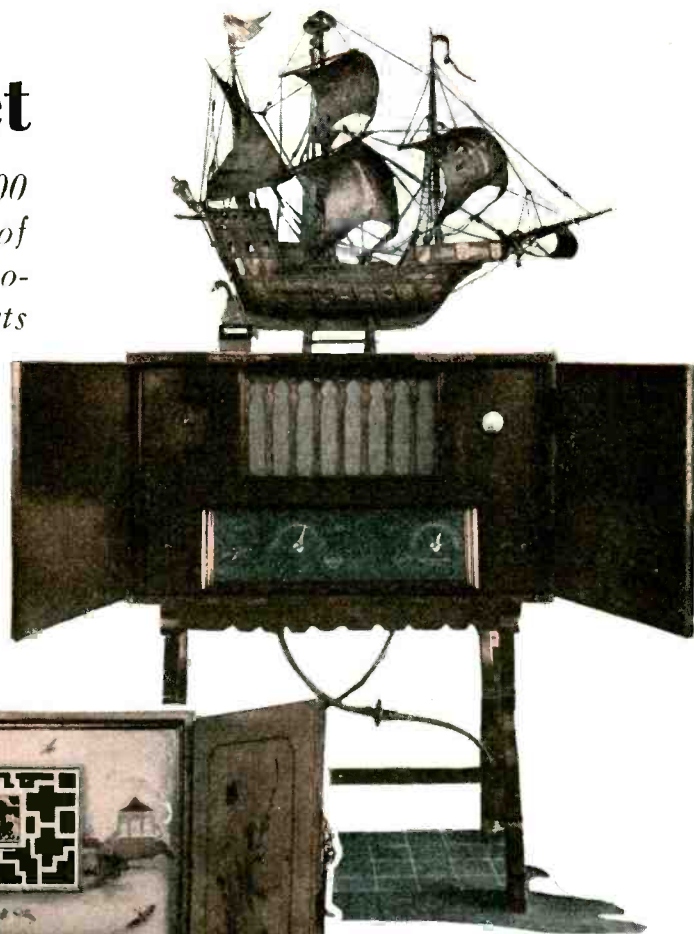

ness with one business policy firmly fixed in his mind—to carry nothing but quality merchandise. His first receiver retailed at \$350, an almost unheard of price at that time. He sold it and it stayed sold. Today his buying policy remains as inflexible as the day he started in business. Nothing but high grade merchandise finds a place in the store. He carries only three lines of receivers. The cheapest retails at \$160. Several are listed at \$1,400. Quality merchandise is the secret of his success.

The nature of the stock Barrows carries is conducive to good business. His experience with high grade merchandise may be outlined in a few sentences. Little cut price competition, many satisfied customers, less service and few "shoppers" to contend with is the result of his quality stock selection.

People come into the shop to be sold good merchandise. They are willing to pay for it when convinced that they are getting their money's worth. This is the reason why Barrows' customers are satisfied. The advertising value of a satisfied customer cannot be reckoned in dollars

Some of the special cabinets Barrows has made to customers' orders

radio apparatus; \$7,500 in radio receivers and accessories is in the homes of Great Neck prospects on demonstration, and Barrows has accounted for more than \$100,000 worth of radio business since his arrival.

Barrows went into busi-

and cents, but it is significant that the shop sold \$50,000 worth of radio apparatus last year with little direct advertising.

Cut-price competition is minimized. Though Great Neck is within twenty miles of the New York City shopping center, Cortlandt Street, Barrows has no competition. He is the exclusive local distributor of the three lines he carries and the type of customer who buys in his shop is not influenced by cut-price ads. The prime demands of his customers are satisfaction and service and Barrows is headquarters for both. Prices in the higher priced receiver class have been stabilized. He does not have to contend with unfair competition. Prices are quoted from the manufacturer's catalog. Customers are thus impressed with the reliability of his merchandise.

Service has been reduced to a minimum. Barrows spends less than 2 per cent of his net profits on service. His records show that only 5 per cent of the receivers sold in the past 2½ years have required service other than a normal replacement of batteries, for which he makes a reasonable charge. Every receiver is thoroughly tested before leaving the shop. "Naturally," he explains, "a man cannot reasonably expect to buy a receiver of the type he would care to own at a cheap price. He cannot buy an automobile of Packard or Cadillac quality at Ford prices. Chattering and Ampico pianos are not available at anywhere near the price of numerous "nameless" grands which have appeared on the market. The average resident of Great Neck cannot build the kind of a home he would like to live in for \$10,000, and it is not reasonable to think that the best receiver obtainable may be bought for \$75 or \$100. The receivers I stock are high priced, yes, but they are real value. The manufacturer can afford to construct them for years of use. That is the reason for my exceptional service record."

High priced receivers may be sold just as easily as the cheaper models, according to Barrows. "Of course it is impossible to make a success of a business in many localities exclusively on this basis, but there is a market for quality merchandise in every neighborhood. In mine it happens to be the bulk of the market.

"In my opinion, the average prospect can afford to buy a good re-

ceiver. A good salesman can persuade such a prospect to buy something that need not be replaced in a short time. The high cost of quality receivers is not a sales disadvantage. A comparative demonstration usually convinces the prospect that there is a difference that warrants the price. I estimate that 90 per cent of my business is completed on the comparative demonstration basis.

"From the standpoint of the dealer, the sale of high priced goods is very profitable. I can afford to spend more time in the sale of a \$300 receiver than if I am trying to sell a set listing at \$100 complete. One cheap receiver requires at least as much service as an expensive one and the margin of profit per unit sale is much less. The quality sale represents an investment of two to three



"Buzzing charger, trailing wires, wet batteries" are not pleasing to the housewife. A radio cabinet with a pleasing exterior is the secret of many of Barrow's sales to women customers.

times the money by a customer, and the receipt of double or triple the profit by the dealer. I can well afford to pay more attention to the service requirements of such a customer."

The Radio Architect

Barrows has created his own niche in the radio industry. At least insofar as Great Neck business is concerned. He resells many of his old customers by designing cabinets to match the interior of their homes. The "exclusive" idea is played up, for he will not duplicate. No two cabinets are alike and as they are built-to-order, design ideas of critical customers may be incorporated.

During the past year Barrows has sold 11 of these special jobs averaging \$900 per sale. The trade discounts are slightly higher than standards on radio equipment, and profits are absolutely clear.

"Custom-built cabinets is a two sale proposition," says Barrows. "The man usually selects the receiver for its mechanical and receptive qualities. He places it in his home with little regard for its appearance. Reception is satisfactory, he is pleased, but very shortly he begins to realize that it is necessary to conceal batteries and to equip the set with some sort of a cabinet so that it does not detract from the appearance of the home. Perhaps his wife has something to do with it. Trailing wires, buzzing charger or a wet battery standing ungracefully in a corner of the living room become objectionable after the novelty of the first few weeks of reception wears off.

"The wife usually selects a cabinet to go with her receiver. Both she and her husband must be sold on a 'cabinet to fit the home.' Advertising or flashy sales methods in connection with the sale of these expensive specials do not pay. Every sale I have made of this kind is the result of personal contact with the prospect. A word dropped here and there suffices to show that an old customer may be interested and I take advantage of all the 'breaks.'

"A photo of a similar cabinet is absolutely necessary in the sale of custom built cabinets. Few customers can visualize such a job unless the salesman is an apt hand with a pencil and can sketch the model or is supplied with a photo of standards. I recall an incident in the sale of an expensive receiver completed a few weeks ago. The prospect was a wealthy contractor. Probably he had put over a successful deal a few days before he entered my store, for he was very much interested in a \$1,400 model then on the floor. I tried to interest him in an exclusive cabinet job to match the Spanish interior of his home. His wife came down to the shop the other day and placed an order for a rather ornate stock receiver. She could not visualize the special cabinet."

While every town has not the "wealth per capita" which this Metropolitan suburb boasts, every town has an "exclusive" section whose residents can afford "special" jobs.

Radio Legislation In Sight

*Conferees Approach Agreement. New Radio Bill Introduced.
Engineering Council Appoints Radio Committee*

WITH a deluge of petitions, letters, and telegrams descending upon Congress, praying for radio relief, increasing pressure is being brought upon the Radio Conference Committee of both houses to speed its activities and to agree upon practicable radio legislation at once. Senator Dill and Representative White, the authors of the two radio bills in conflict, have held a number of conferences and are believed to be approaching agreement.

"The conferees have held many meetings," explained Senator Dill on the floor of the Senate, in answer to a question from Senator Bingham of Connecticut, "and at every meeting have made progress. We have reached a tentative agreement on the chief principle involved—control. A compromise between the House and Senate bills is being written. We are in sight of the end."

The Underhill Bill in the House

Notwithstanding the repeated assertions of members of the Conference Committee that they were near an agreement, a wholly new bill to regulate radio by placing it wholly and completely in the hands of the Secretary of Commerce, was introduced in the House on January 5 by Representative Underhill of Massachusetts, as House Bill 15909. Mr. Underhill in explaining his measure "granting authority to the Secretary of Commerce to regulate radio communications" explained that its purpose was to simplify radio control. "The other bills," he said, "are far too complicated. I have left out all minor details, because in my opinion these should be left to the Secretary to decide at his discretion." Other members of Congress doubted that attention would be given to this new bill, unless the conferees failed to agree.

Meanwhile Representative Crowther of New York, on the floor of the House, declared against the "foolish delay" of radio legislation in the Conference Committee. "The regulation of broadcasting is a simple matter," he said, "and the pleasure and comfort of many people are at

stake." Representative Treadway of Massachusetts, also expressed his impatience with the Conferees, and demanded action in one form of control or another.

Creation of a board having judicial functions in disputes over wavelengths and other radio controversies which may come up in connection with the licensing problem, was suggested by President Coolidge on Jan. 14 as an important factor in the machinery for handling the situation, it was stated officially at the White House.

It was stated that Mr. Coolidge desires, if possible, to avoid setting up a new independent commission and has been anxious that the radio licensing function be established in such form as to continue functioning with the Department of Commerce.

Radio chaos is inevitable unless Congress passes legislation to regulate broadcasting, Dean Dexter S. Kimball of the Cornell University Engineering School told the Ameri-

can Engineering Council at its meeting at Washington, Jan. 14. The Engineering Council represents the affiliation of the principal engineering societies of the country, to deal with national and governmental problems.

The council has appointed a committee to conduct a nation-wide investigation of broadcasting in an effort to bring out facts upon which an effective scheme of Federal control can be based.

The members of the American Engineering Council's radio committee are: Calvert Townley, Westinghouse Elec. & Mfg. Co., chairman; Alfred N. Goldsmith, Chief Broadcast Engineer, Radio Corporation of America; J. H. Dellinger, Chief, Radio Laboratory, U. S. Bureau of Standards; R. S. McBride, Consulting Chemical Engineer; L. E. Whittemore, American Telephone and Telegraph Company; Cyril M. Jansky, Prof. of Electrical Engineering, University of Wisconsin; O. H. Caldwell, Editor of *Radio Retailing*.

The Dill-White Compromise Radio Bill

As "Radio Retailing" goes to press—a compromise radio bill has been reported out of the Conference Committee by Senator Dill and Representative White, with the following provisions:

Commission of five members, appointed by the President and confirmed by the Senate; term 6 years.

During first year, Commission will serve full-time, at salary of \$10,000 per member, and will have full jurisdiction over licenses and revocations.

During second year and thereafter, Commission will act only as appellate body, being assembled on call, at \$30 per diem per member, and will decide only con-

troversial matters referred to it by Secretary of Commerce, or appeals from his decisions.

After first year, the Secretary of Commerce will have full and original jurisdiction over licenses to stations, renewals, etc.

Licenses for broadcasters to run 3 years, other stations 5 years.

No censorship or political restrictions placed on stations.

The loudspeaker that has

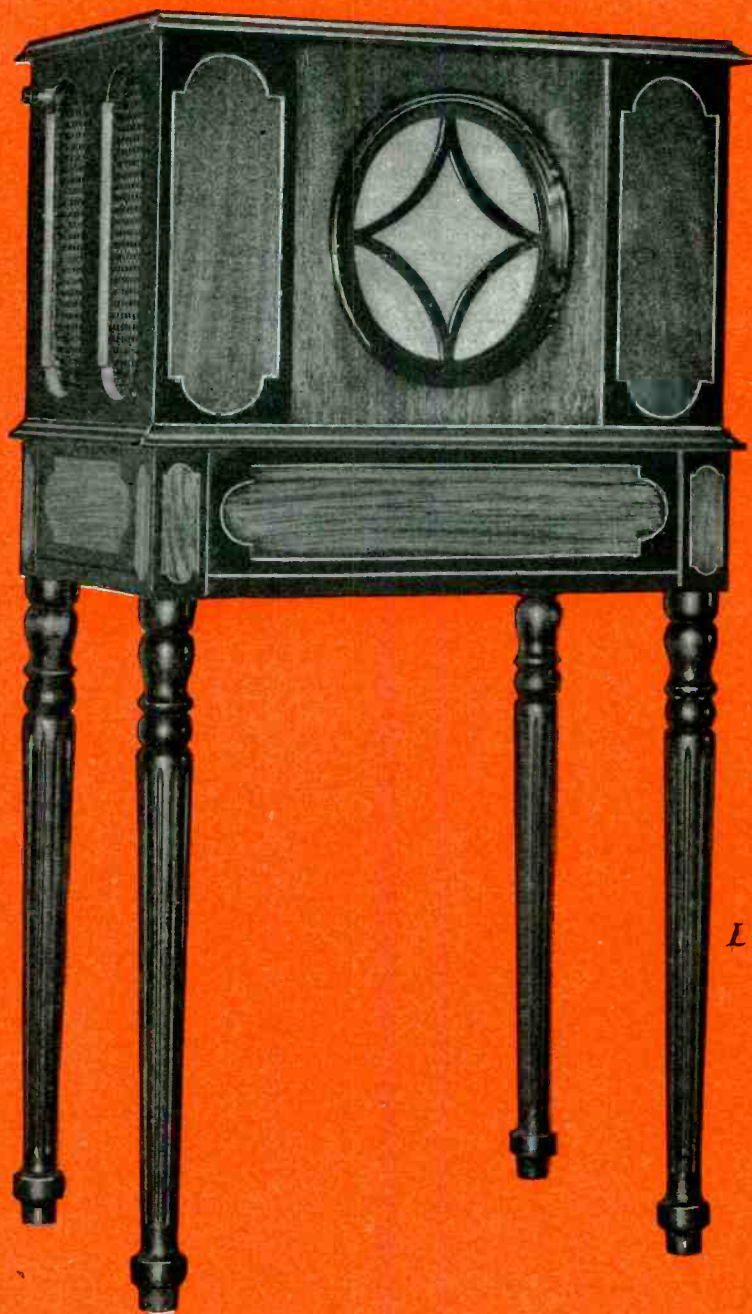

RCA
LOUDSPEAKER
104

RCA Loudspeaker 104
List. \$275
For 50-60 cycle, 110 volt
A. C. lighting circuit)

RCA *~* Loudspeaker

MADE BY THE MAKERS OF THE RADIOLA

made radio triumph in *MUSIC*

IT was in the designing of this remarkable loudspeaker that the development of the modern era of "electrical reproduction of music" began. It operates from the lighting socket—makes possible infinitely finer musical tone—at any volume.

When adapted with Radiola 25 or 28, it eliminates all batteries. With most other sets, it does away with "B" batteries. It makes any good radio set *entirely new* in performance—makes it modern.

In point of public demand as well as proved performance, RCA Loudspeaker 104 is the leading *musical instrument* of radio today! Sell it by home demonstration—and it quickly sells.



RCA Loudspeaker 100—clear at any volume a set can give it. List, \$35



RCA Loudspeaker 102— with a power amplifier, A.C. operated. List, \$140

RADIO CORPORATION OF AMERICA
New York Chicago San Francisco



RCA *~* Loudspeaker

MADE BY THE MAKERS OF THE RADIOLA

Know Your Business at a Glance



How one standard record form has been adapted to every book-keeping need—a practical and simple method of control.

By RAY V. SUTLIFFE

Editor's Note: The January issue of this magazine contained an article which described the methods used by Glidden Baldwin of Danville, Ill., in preparing a sales quota and budget control for the entire year. The need, in this connection, for keeping a complete record of pertinent business statistics was stressed.

Certain facts and figures concerning every business should be recorded

daily and summarized every month whether or not it is the intention of the owner to set a sales quota to shoot at.

But in case the stimulating influence of a sales goal is set, then the need for a few simple records of past progress is imperative.

In this article Mr. Sutcliffe describes such a fact-finding system. He uses for his example Mr. Baldwin's sin-

gle-form control method. It was from this form that Baldwin assembled the facts for his quota sheet which was analyzed last month. This system is so simple that it can be maintained by the average clerk or by the proprietor with an expenditure of a comparatively small amount of time each day. That effort will be well spent, indeed, as Baldwin's business proves.

"YOU'RE just in time to enjoy a venison steak," exclaimed Baldwin, "let's talk it over at lunch." Baldwin, it appears, had found time, just before the holiday rush, to spend a week in the woods of Wisconsin and had returned in triumph with a fine young buck. "It was my bookkeeping system that really let me get away," he declared. "You see I felt that everything would go along smoothly without me there for a few days and I knew that when I returned I would be able, from the books, to find out in quick order just what had happened since I left."

Right here may I pause to remark that a fresh venison steak is just as much a treat for editors as for ordinary mortals. After it had been dis-

posed of, Baldwin told me about his foundation facts-keeping system.

"The sales quota and budget forecast which I am keeping may not be absolutely essential to the success of a retail radio store, but certain daily and monthly records are," he said.

Baldwin then listed the following "key" records. His system consists of a number of identical form cards, on which are written in the numerical headings in the list below. Here they are, grouped according to main classifications and supplemented by explanatory remarks.

A. Financial Administration

1. Accounts Receivable

A daily running balance of moneys received on customers'

accounts and the outstanding total. (See B-3.)

2. Notes Receivable

A record of customer notes due and of payments made. (See B-3.)

3. Accounts Payable

A running balance of moneys owed and payments made—by day and by account.

4. Accounts Payable, No. 2

A record by separate sheets of each creditor's account.

5. Notes Payable

A record by individual notes of payments made on same, and due dates.

6. Discounts Earned

When a bill is discounted the earned cash discount is en-

How Baldwin's "One-Form Control System" Does It

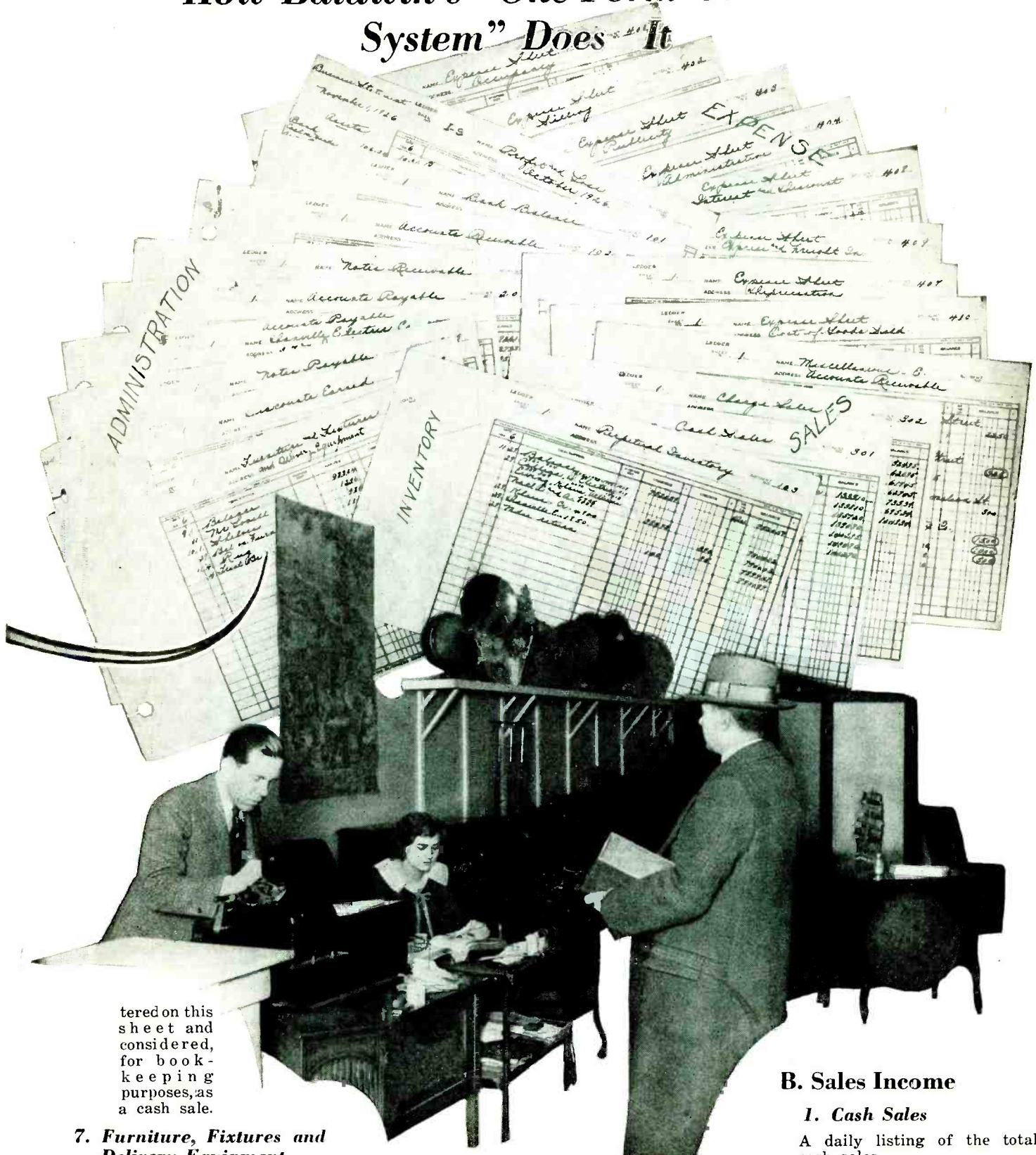

tered on this sheet and considered, for book-keeping purposes, as a cash sale.

7. Furniture, Fixtures and Delivery Equipment

A record of fixed assets. From this balance is deducted monthly the proper amount (according to the item) for depreciation.

8. Bank Balance

A duplicate of the bank book.

9. Monthly Profit and Loss Statement

This is rendered in two ways. (a) Selling expenses (itemized) plus cost of merchandise, plus net profit, equals sales; (b) an asset and liability statement.

B. Sales Income

1. Cash Sales

A daily listing of the total cash sales.

2. Charge Sales

A daily listing of the total charge sales.

3. Accounts Receivable

A separate page for each important customer account

showing purchases and payments; and a "miscellaneous" sheet for smaller accounts.

C. Stock Record

1. Perpetual Inventory

Baldwin makes an honest attempt to keep this. A hard thing to do, but he has an efficient helper who knows stock costs and watches stock flow. To keep inventory up to date, when incoming items are recorded at invoice (cost) prices, necessitates the costing of all sales. This is desirable, however, as it gives the information from which the total cost of the month's sales may be determined and this latter figure is essential in arriving at the net profit.

Baldwin's bookkeeper-clerk "costs" each sale on this perpetual inventory sheet daily when she takes off the day's sales from the register slip. This is done by assigning to each sale its proportionate share of the total expenses.

D. Expense Control Sheet

1. Occupancy

Watchman, rent, water, light, heat.

2. Selling

Pro rata portion of owner's salary and of that of the bookkeeper-clerk, service men and salesmen, according to the time devoted to selling.

3. Publicity

Newspaper advertising, solicitations, direct-by-mail and window cleaning.

4. Administration

Miscellaneous postage, supplies for office, wrapping materials, etc. Put here the proper proportion of bookkeeper's salary based on time spent in clerical work. Telephone and telegraph.

5. Service

That monthly servicing expense, if any, not covered by service charges. The servicing income and outgo should, therefore, be kept as a separate account. Proportionate service car expense.

6. Delivery and Installation

Oil and gas, garage rent, tires, pro rata driver's salary and installation expense. The latter can be estimated from the sales slips closely enough. Former expenses shared with "Service."

7. Taxes and Insurance

Paid yearly, but must be divided in twelve parts and

entered on the monthly statement.

8. Interest on Borrowed Capital and Invested Capital

On the theory that this tied up capital, if invested, would pay six per cent. Interest on borrowed money is an expense.

9. Express and Freight

10. Depreciation

Twenty per cent on automobiles; eight per cent on fixtures.

11. Bad Debt Losses and Collection Costs

12. Cost of Goods Sold

This is necessary if net profit be determined. (See C-1.)

THERE are 25 vital subjects concerning one's business on which every merchant should be fully posted at all times. This article tells what these items are and how this information, in simple and complete form, may be obtained.

It is self-evident that this information, concerning the state of one's business affairs, which the preceding records make available almost at a glance, is exceedingly valuable.

"But isn't it complicated?" or "That stuff may be all right for Baldwin, but it would be too much for me to keep up!" I can hear many dealers exclaim.

Wait a minute. Read a little further. It will be time well spent.

Recording Machine Cuts Clerical Labor in Half

There are two reasons why it is entirely feasible to keep the information just outlined. First, the fact that there are many inexpensive recording machines on the market for making the original entry of all manner of transactions at the time they occur. Second, the use of one simple form for the permanent recording of all these items of business information. Note also that much of the information which goes in groups A and D, "Financial" and "Expenses," for example, is entered but once a month. Many other operations take but a few minutes a day and must be kept if anything at all

is to be known about the business. Why not, therefore, keep this pertinent information in orderly fashion, and, by the expenditure of two or three more hours a week on the books, have, at the end of the month, a picture of that month's business which really means something?

Most registering machines provide means to enter the name and nature of the transaction and keys which permit the quick and accurate printing, on this same slip, of the amount involved and the account to which it is to be credited or debited. Baldwin's cost \$135 and is equipped with the following key characters: PD (paid out); GR (goods returned); CH (charge sales); AC (received on account or in full); NS (no sale); E (service); D (sets); C (tubes); B (batteries); A (accessories), and identification keys for five clerks. It will be seen that salespeople are enabled to make a record, at the time the transaction occurs, of these all-important facts; name and address of the customer or creditor; identification specifications of the items involved; date; amount; nature of transaction; department and clerk who handled it.

For making the original entry speedily and accurately there is the machine, but what of the final record? One form and one book are sufficient, according to Mr. Baldwin. The form, in his case, measures 7x9 in. At the top is space for the account name or number and the necessary identification information. The ruled portion of this universal card reads, from left to right, like this: date, description, posting reference, charges, credits, debit or credit, balance.

The daily bookkeeping routine proceeds somewhat in this manner: The first thing in the morning the printed and written entries on the machine slips of the previous day are transferred to their proper places in the "one-form" record book.

For instance, the first slip taken up may be the charged sale of a \$65 set and \$10 worth of tubes. This is entered on account sheets B-2 and B-3. It is then filed for reference when the perpetual inventory C-1 is brought up-to-the-minute. When paid, the item is checked off on B-3 and also entered on A-1.

The next slip may be "cash paid out for expressage, \$1.84." This is entered on "Accounts Payable," A-3, and also D-9, "Express and Freight."

Please turn to page 64

Television Among Month's Radio Events

Getting Radio Ready for Future Wars

A radio receiver and transmitter in an armored motorcycle is a recent German invention.

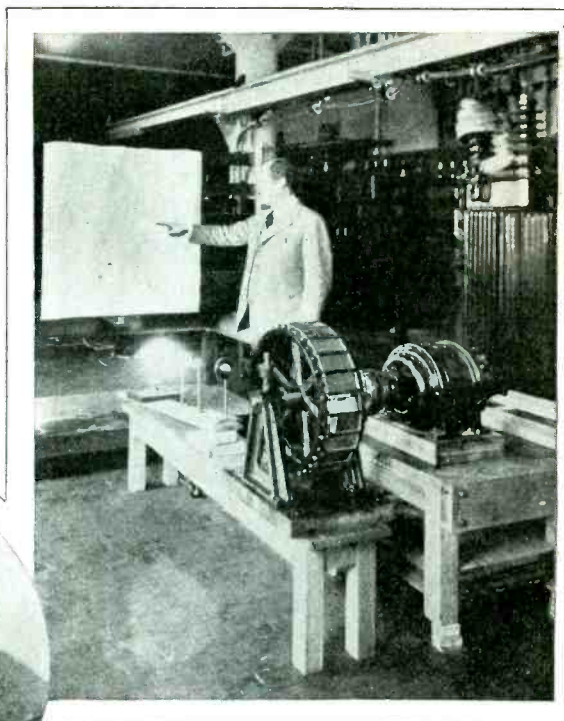

Tracing Static

The instrument shown at the right is an electrometer for measuring the quantity of electricity in the air. It has proved very valuable in radio experiments. The one pictured here is in use at the Carnegie Institute.

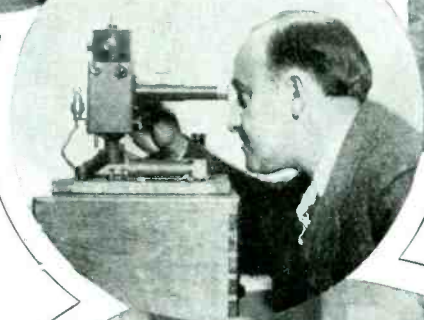

Makes Television Possible

Above, Dr. E. F. W. Alexanderson and his invention which promises to make television possible. This machine projects moving pictures of what is happening miles away. Dr. Alexanderson is seen pointing out on the screen the spots of light that paint a picture in one-sixteenth of a second.

What, No Batteries?

Senator Dill, right, author of the Senate radio bill, is seen tuning in. He looks a bit nettled as he tries to bring in his station clearly.

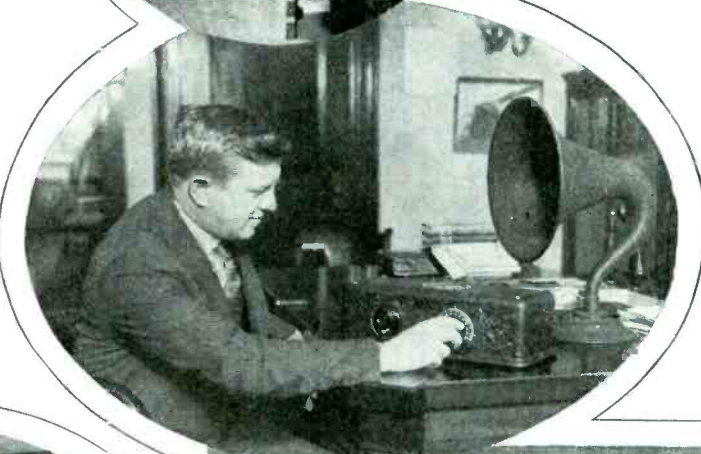

"Showing Up Interference"

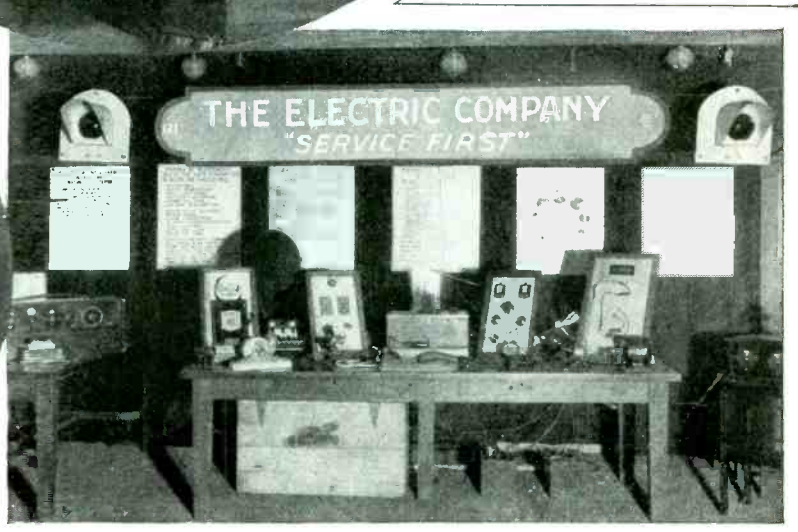
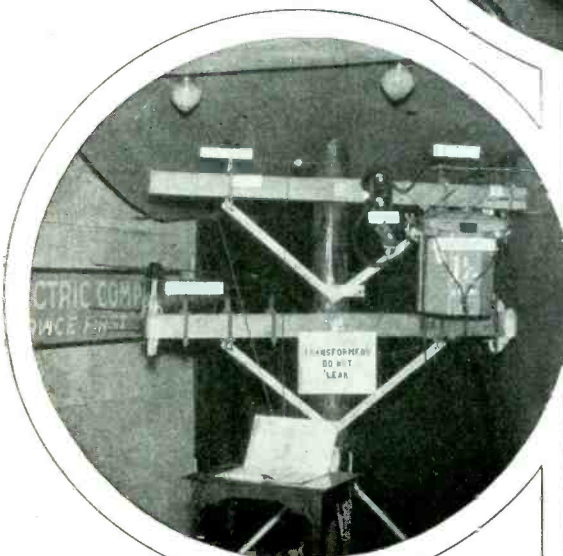

This exhibit of the Indiana and Michigan Electric Company at a recent radio show at Milwaukee was designed to show the causes of interference and their

remedies. The photographs show how the sources of interference and the methods of overcoming them, were graphically explained.



Separating
Those Who Want to Buy

ALMOST every customer who buys a radio set likes to come in and talk about it. Sometimes he has just connected up with Oshkosh or got Denver on his set, but more frequently he wants to know just what is the cause of the strange noise which comes when he turns his dial in a certain direction and whether it can be true, as his neighbor says, that the power lines in his vicinity are spoiling his programs.

This conversation is of value to the store which sells radios because it means a friendly relation between itself and its customers and because, also, it means that when the neighbor next door expresses a desire for a set just like the one he has come in to hear, that fact will be reported as well, or he will be sent in to make the inquiry himself. On the other hand, as every dealer knows to his sorrow, there are times when the conversational customer is a nuisance.

How many times has a sale been lost or threatened because the cus-

tomer has been hurried in his decision through seeing others waiting for the salesman with whom he was talking? That the others may only be waiting to report that their set had been acting up and they wish someone would drop around to look at it, they cannot know, but they are conscious of the necessity of making a prompt decision and, being hurried, it is too often "no." Or, if the man with the small complaint happens to be first, how long will the hesitating prospect wait while the necessarily courteous exchange of amenities goes on before him?

Many stores provide separate salesrooms in the form of demonstration booths into which individual customers may be taken and where

the sale may be completed without interruption. But this takes the salesman off the floor and makes the situation in regard to the waiting prospect even worse. If no one at all is there to wait on him, he soon goes about his business and makes his inquiry elsewhere.

A method to keep the interest of the owner of a new set and secure his good will, and at the same time keep the sales floor free from conversation and confined to selling, has been devised by the radio department of Meier and Frank, Portland, Oregon, under the management of William A. Hodecker. This method is to create two entirely distinct departments, both of which function in the sale of radio, one confined to

Meier & Frank, Portland, Oregon, devise "Information Window" to give salesmen more time for selling.

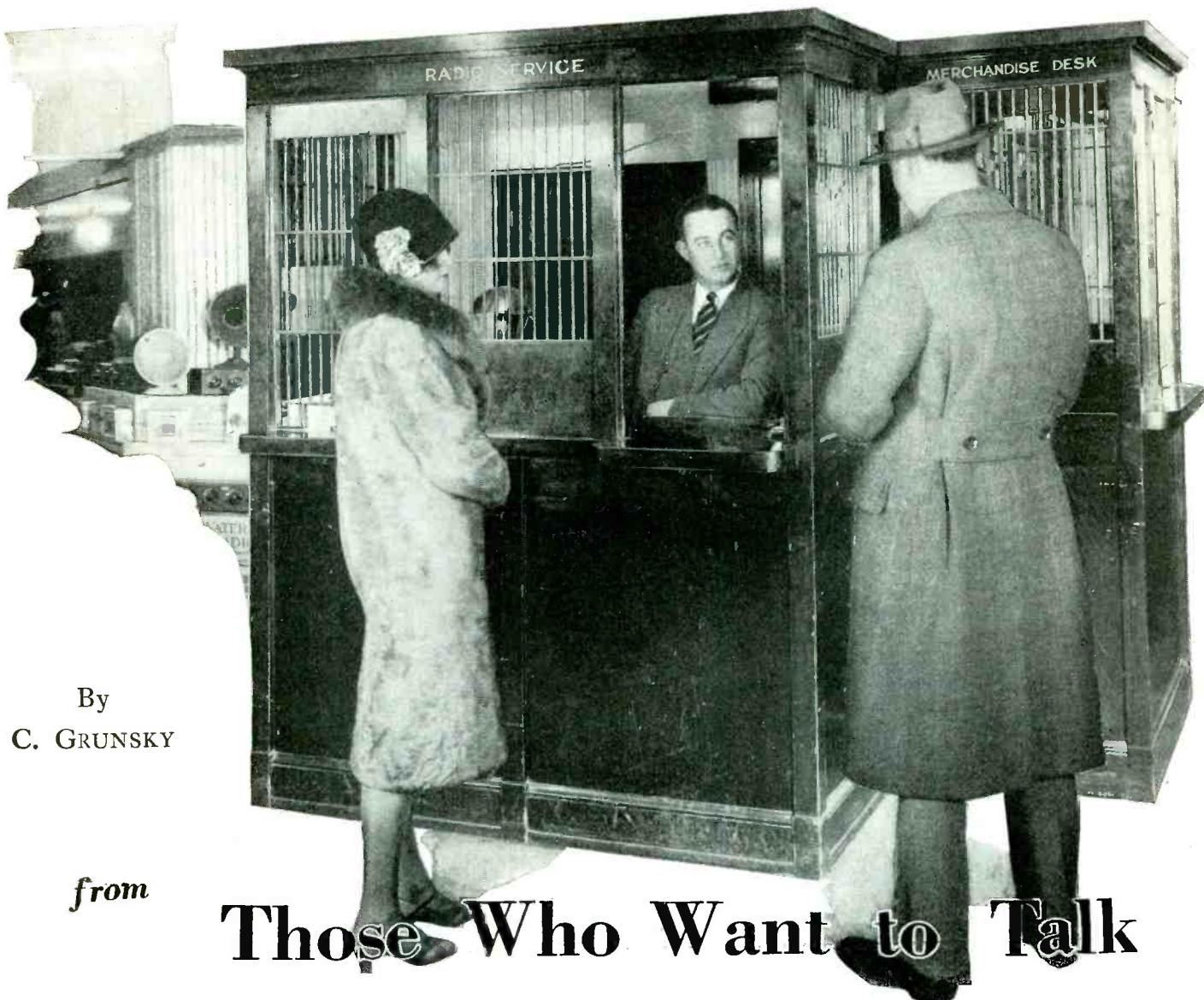

By
C. GRUNSKY

from
Those Who Want to Talk

making the sale and the other handling all other contacts with the customer.

The initial step in this separation has been the barring of all technicalities from the process of selling. The salesmen under Mr. Hodecker are instructed to sell the broadcasting programs, entertainment in the home, music, education, enjoyment—anything but machinery.

Further to expedite sales, no demonstrations are given, either in the home or in the store. This means, among other things, that no salesman is in the field away from his post of advantage and also that he is not secreted for an indefinite period at the customer's whim. Sales take a much shorter time to complete on an average and therefore a smaller sales force is required to handle them.

The policy of the Meier and Frank store has long been an absolute guarantee of satisfaction with all

goods sold and this is given unquestioningly with radio. If the customer understands in the first place the limitations as well as the possibilities of radio, if she has been sold the instrument which fits her needs and her purse, she will not bring it back. If she does, the store feels that it is a cheap protection of its reputation to make the necessary exchange. The actual loss under such a policy as this has been found to be very small, almost negligible. In this connection, the lessening of the cost of overhead is an item which should not be overlooked.

The questions asked of the customer are these: What is your neighborhood? Do you want dry or wet batteries or eliminators? How many tubes? What is the price range in which you are interested?

Long experience with sets sold into all sections of the city has built up in the minds of the salesmen a very complete picture of receiving condi-

tions in all districts. It has shown also that it does not pay to sell an expensive set to a customer living in a neighborhood where reception is poor and where nothing can be counted upon but local broadcasting. It is better to be frank in the first place, to explain to the customer what conditions are in that district and to advise the purchase of a less expensive set which will cover adequately local stations.

If the customer is mechanically inclined and insists upon talking hook-ups and wiring, he is turned over to one of the experts from the service department who can compare notes with him to his heart's content.

This service department is a separate organization entirely from the sales force and deals with the customer as a rule without any reference to the other department. In other words, the salesman does not take the data for a service call and

Please turn to page 64

Analyzing the World Market for Radio Equipment

By HARRIS E. DEXTER
Chief, Electrical Equipment Division
U. S. Department of Commerce

RADIO equipment is the second largest group of purely electrical material, so far as value is concerned, exported from this country. Interest in radio broadcasting is increasing throughout the world, as is attested by the value of radio receiving apparatus exported from the principal manufacturing countries. Of this total business about 50 per cent is in American-made apparatus, though only about 5 per cent of the radio equipment made here is exported. As broadcasting stations are established in areas not now served, as the quality of programs improves, as the purchasing power grows, and as better receiving sets are made, the market may be expected to expand. An increasing amount of this business may come to American firms, as our equipment is generally regarded as the best.

Probably no industry has ever shown the rate of growth attained by the radio business as a whole. Table "A" on this page gives the value of radio equipment exported from the United States during 1923, 1924, 1925 and most of 1926 to various areas and to the world as a whole. During these years our business increased 3.4 times.

The variations, month by month, in this total business for the same years as well as for the most of 1926, are shown also by the diagram on the following page.

United States Radio Exports

	1923	1924	1925	1926 10 mos.
Netherlands.....	23,859	53,665	138,695	128,560
United Kingdom.....	199,626	142,291	644,916	348,137
Canada.....	799,584	2,420,882	3,703,132	1,902,663
Cuba.....	212,288	103,486	84,087	83,575
Argentina.....	646,993	291,740	408,593	553,447
Brazil.....	23,484	178,910	358,256	203,954
Other South Am.....	136,670	245,187	232,374	140,604
Australia.....	210,214	1,052,707	675,483	1,046,632
Japan.....	45,761	358,222	2,216,535	495,837
Other countries.....	1,149,632	1,183,824	1,446,716	1,237,134
TOTAL.....	3,448,111	6,030,914	9,903,787	6,140,543

Table "A"

THIS is the first of a series of three articles on the radio export situation prepared exclusively for *Radio Retailing* by the U. S. Department of Commerce.

The United States is the leading radio exporter of the world. Its exports total radio equipment in 1925 was \$3,407,325 greater than that of the United Kingdom, its nearest competitor. British radio exports to Europe, Oceania, and Africa were greater than ours, but American manufacturers provide keen competition in those areas and their sales are steadily increasing.

Exports of radio apparatus from the United States reached a total value of \$9,903,857 in 1925. American sales to the United Kingdom were valued at \$644,916.

Exports from the United Kingdom were valued at \$6,496,532 for 1925. The value of direct exports from the United Kingdom was \$6,275,918 and that of re-exports totaled \$220,614. British shipments to the United States totaled \$268,847, of which \$7,338 was of the re-export class.

The European purchases of radio from the United Kingdom, excluding those of the Channel Islands, totaled \$2,681,339—a little more than three times the value of American exports to European countries, excluding the United Kingdom. The total American radio exports to Europe,

excluding those to the United Kingdom, were less than the British sales to the Irish Free State, Netherlands and Spain. Spain and Hungary were the only European countries to which we shipped more radio equipment than did the United Kingdom. (See Table "B").

Radio Exports of the U. S. and the United Kingdom to Europe in 1925*

(*Including exports of the United Kingdom to the Channel Islands and to the United States and those of the United States to the United Kingdom. Latest figures available.)

Countries	U. S. Exports	U. K. Exports
Austria.....	\$8,181	\$66,189
Azores and Madeira.....	895	2,266
Belgium.....	18,524	101,359
Bulgaria.....	441	939
Czechoslovakia.....	71,372	07,778
Denmark, Iceland and Faeroe Islands.....	29,077	132,905
Estonia.....	137	2,036
Finland.....	1,452	5,858
France.....	38,661	188,923
Germany.....	22,975	74,231
Gibraltar.....	430	2,335
Greece.....	1,499	46,396
Hungary.....	2,670	2,440
Irish Free State.....	656	394,557
Italy.....	53,071	148,744
Latvia.....	325	724
Lithuania.....		35
Malta, Gozo and Cyprus Islands.....	1,306	7,015
Netherlands.....	138,695	296,997
Norway.....	52,092	125,144
Poland and Danzig.....	2,207	155,853
Portugal.....	14,942	32,914
Rumania.....	1,408	55,584
Russia.....	28,419	64,795
Spain.....	230,265	216,586
Sweden.....	122,451	161,594
Switzerland.....	10,227	91,840
Turkey, in Europe.....	195	7,499
Yugoslavia.....	43	11,236
Total.....	852,616	2,504,372
Channel Islands.....		52,781
United States.....		261,509
United Kingdom.....	644,916	

Table "B"

Exports to the Channel Islands, the United States and the United Kingdom are separated from the European group in order that a more accurate estimate of the relative importance of British and American sales in Europe may be made.

The Canadian Market

American radio exports to Canada during 1925 totaled \$3,703,133; the United Kingdom's \$259,251. Our sales to Latin America exceeded the United Kingdom's by \$1,485,023 to \$343,317. Mexico purchased \$272,135 American equipment and \$1,713 British. United States exports to Central America and the West Indies were more than 7 times greater

than the United Kingdom's and our sales to South America were more than three times the British. British sales in Central America and the West Indies exceeded ours only in the case of the British West Indies and the Dutch West Indies, which purchased about 88 per cent of the total radio equipment shipped by the United Kingdom to Central America and the West Indies.

South America Favors United States' Manufactures

American radio manufacturers' sales to South America were more than treble those of the United Kingdom to that continent and the Falkland Islands, although British shipments to Guiana and Peru exceeded ours.

The Peruvian Broadcasting Co., controlled by the Marconi Co. of Great Britain, had a monopoly on the importation of radio equipment. This caused the greater sale of British radio to Peru during 1925 but the monopoly does not exist now and American shipments should increase. Brazil was the leading South American market for United Kingdom radio exports, but even there they were less than one-third those of the United States. The Falkland Islands purchased radio valued at \$19,951 from the United Kingdom and none from the United States. Over 7 per cent of the total shipments of the United Kingdom to South America went to British possessions. (See Table "C.")

Radio Exports to Canada and Latin America in 1925

(Latest figures available)

Countries	U. S. Exports	U. K. Exports
Canada	\$3,703,133	\$257,747
Mexico	272,135	1,713
Central America and West Indies:		
British Honduras	2,549	375
Costa Rica	4,447	
Guatemala	13,408	856
Honduras	9,670	
Nicaragua	7,476	
Panama	15,964	
Salvador	37,354	
Bermuda	12,189	1,349
British W. Indies	11,324	12,948
Cuba	84,087	749
Dominican Republic	9,360	
Dutch West Indies	1,624	13,961
French West Indies	11	
Haiti	2,129	
Virgin Islands	2,173	
Total	213,765	30,237
South America:		
Argentina	408,593	82,737
Bolivia	1,458	
Brazil	358,156	112,229
Chile	113,671	36,787
Colombia	12,742	4,832
Ecuador	9,594	219
British Guiana	1,086	6,686
Dutch Guiana	979	
Peru	34,394	45,765
Uruguay	55,307	366
Venezuela	3,143	2,155
Falkland Islands	999,123	19,591
Total	999,123	311,367
Total for Latin America	\$1,485,023	343,317

Table "C"

Radio Retailing, February, 1927

American radio exports to Asia, excluding the Philippine Islands, exceeded the British by \$808,909. British exports were valued at \$1,497,350, of which over 23 per cent went to divisions of the British Empire. Japan was the leading market for British radio equipment, but even there American sales were more than double those of the United Kingdom. The United States radio exports to Japan alone were almost \$726,000 greater than the total sales of British radio in Asia. Our radio exports to Netherlands East Indies topped the United Kingdom's by \$3,383, and our shipments to China were greater by \$1,851. United States radio exports to the Philippines were valued at \$109,030. No British shipments to these islands were recorded.

British radio exports to Oceania totaled \$1,056,583, 36 per cent greater than ours. The United Kingdom exports to Australia alone were valued at over \$200,000 more than the American shipments to entire Oceania. Our sales to New Zealand exceeded the British by \$33,454, or 51 per cent. No British shipments were recorded for French Oceania. Our exports to that territory totaled \$312.

United States radio exports to Africa totaled only \$25,281; the United Kingdom's \$336,825. British South Africa, the leading market in this area, bought radio valued at \$20,334 from American manufacturers and \$259,285 from the United Kingdom. Egypt took \$2,796 worth from the United States and \$29,099 from the United Kingdom. French Africa, which purchased \$275 worth of American equipment, was the only territory in this area which imported more radio manufactures from the

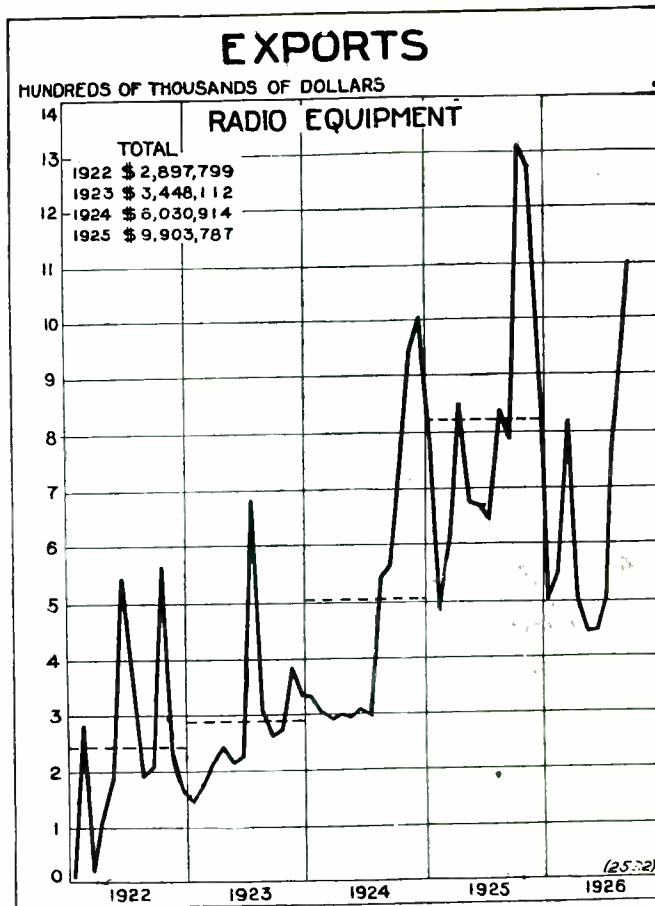

The variations, month by month, in the total exports of the United States during 1922, 1923, 1924, 1925 and most of 1926, are shown in the above diagram.

United States than from the United Kingdom. The total British radio exports to South Africa was 10 times greater than our shipments to the whole of Africa.

Table "D" gives the export value of radio apparatus in 1925 from the United States and the United Kingdom to Asiatic, Oceanic and African purchasers.

Radio Exports to Asia, Oceania and Africa in 1925

(Latest figures available)

Countries	U. S. Exports	U. K. Exports
British India	29,941	269,133
Other British East Indies	7,208	29,050
China	30,381	61,976
Dutch East Indies	14,438	11,055
Japan and territories	2,223,340	1,083,074
Philippine Islands	109,030	
Other Asia	901	22,229
Australia	675,483	973,842
New Zealand	98,365	62,100
Other Oceania	3,751	1,970
British South Africa	20,334	253,500
Other Africa	4,947	77,453

Table "D"

In the March issue of "Radio Retailing" will appear the second of this series of three articles on the Radio Export situation written exclusively for this publication by the U. S. Department of Commerce experts.



Napoleon is reputed to have said that an army will fight better after it has been fed. This dealer feeds his prospects before asking them to "sign up"

Sandwiches and "DX" for the Guests—and

More Business for the Dealer

How Alfred Auger of Middleboro, Mass., sold twenty-eight sets in a town of 9000

ALFRID AUGER, of Middleboro, Mass., believes in mixing business with pleasure—and gets some very good radio prospects as a result. Auger has three or four "preferred" customers. To these he is unusually nice. Drops in on them at eleven or twelve o'clock at night, if he sees a light in their sitting room as he goes by. Gives them the best of personal attention. Sees that their sets are always right up to scratch.

So friendly has he intentionally become with this little group that any one of them is more than glad to help him stage a real "DX radio party" any time he wants to.

What is a "DX party?" Simply this. The lady of the house provides a midnight spread. Sandwiches,

cheese, coffee and cake. The man of the house invites in six or eight friends. He tries to have as many of these as possible real prospects. The party starts at ten with the regular run of radio programs from eastern stations. Sometimes the guests dance, sometimes they just sit and listen.

At eleven the dealer drops in and starts reaching out for his elusive friend, "DX." When the clock strikes twelve refreshments are served. The party usually breaks up around one.

This little scheme is cleverly planned, combining, as it does, the lures of entertainment and food and the thrill of "getting California." And what a wonderful opportunity for Mr. Dealer to "get under the

skin" of his prospects. Everyone on an equal basis. All are in a jovial mood.

Auger told a representative of *Radio Retailing*, that he sold twenty-eight high class sets during the past winter by contacting prospects in just such an informal—and personal—way. And Middleboro has a population of but nine thousand residents.

Voltmeter Free with Set of Giant 45-Volt B Batteries

A western New York radio concern gives a voltmeter free with every set of giant 45-volt B batteries. "The customer never forgets who gave him his much needed battery tester," it says. "Furthermore, this plan has started a good many using the giant battery who formerly were content with the ordinary results that the smaller size gave them."

What This Industry Needs

Timely topics of paramount interest and importance to the trade are discussed this month by radio executives and other readers

Misleading Advertisements Should Be Stopped

Editor, *Radio Retailing*:

In recent issues of your publication we have noticed several misleading advertisements pertaining to so-called A-Battery Eliminators. These advertisements claim that the devices contain no battery, which examination shows not to be the case, as each of the units so advertised actually contains a six-volt storage battery.

As you know, everyone interested in radio has been looking forward to the day when batteries would no longer be required for operating a radio receiving set. In view of the successful performance of many B-eliminators, radio fans are easily misled by the above type of advertising and believe that the devices offered are outright A-battery eliminators instead of merely a power unit, containing ordinary storage battery cells, such as they actually are.

This misleading advertising is not only fraudulent, in our estimation, but is demoralizing temporarily the sale of battery chargers and storage batteries, for the reason that both the trade and set users are led to believe that a real A-eliminator has been produced at last and that it is, therefore, useless for them to purchase an obsolete storage battery and charger.

We believe the time has come for action against misleading advertisements of this nature and we would appreciate a thorough investigation on your part, of all such advertising, including our own.

CLARENCE E. OGDEN,
President, Kodel Radio Corporation,
Cincinnati, O.

New Records in Sight for 1927

Editor, *Radio Retailing*:

The radio industry enters the year 1927 on a firmer and more substantial basis than it has ever known before. From the viewpoint of both the manufacturer who produces radio equipment and the public that uses it, the new year seems certain to bring new high records in achievement and satisfaction.

I believe the public recognizes that the day of superficial innovations in radio equipment has passed. Public interest today is centered in the practical and permanent features of radio installation and successful manufacturers have concentrated on the production of equipment to meet that need.

Radio is now accepted with as much definiteness as the telephone, the auto-

mobile or the motion picture. This explains the U. S. Census Bureau figures on manufactures which show an increase of 1,000 per cent in the production of multiple tube receiving sets between 1923 and 1925. We found it necessary, in the Atwater Kent Manufacturing Company, to speed production up to over 5,300 sets a day to meet the 1926 demand.

The utility value of radio, its practical and cultural value, is today recognized as even greater than its worth as an instrumentality for entertainment. The result is that 1927 finds the field for radio expansion and development immeasurably widened, the position of the industry strengthened, and the demand for efficient, simple, high-grade sets greater and more generally distributed than at any time in radio history.

A. ATWATER KENT.

Improving the Parts Business

Editor, *Radio Retailing*:

Your "Merchandising Radio Parts" section of *Radio Retailing* is very, very interesting. In fact, it is a long step in the right direction. There is no question that you are exactly right in the thought that the parts business is a real business, and should not be neglected. As a matter of fact, this is our only business, and therefore it vitally affects us.

Unfortunately, our experience has clearly demonstrated, there are certain abuses to be cleared up, or the radio parts business is going to continue in bad repute, so far as legitimate dealers are concerned. We hope that you, in this new parts section, will help to discourage these abuses, so that eventually it will be a clean business and one that a person, partnership, or corporation will be glad to enter. To aid in clearing up this situation we would suggest the following remedies.

The first is manufacturers' co-operation. We can count the names of the manufacturers *who are ethical*, on our fingers. By this we mean manufacturers who will not sell to consumers direct, either at full retail prices, dealer's prices, or jobber's prices, and who refer all inquiries of consumers direct to their dealer and jobber organizations. In competing with a factory which manufactures certain standard radio parts, we are simply butting our heads against a stone wall.

The second is the elimination of the cut-price jobber who sells to set-building amateurs at dealer's prices with no regard to the dealer, so long as they send a check with the order. This type

of jobber also sells the dealer, and then turns around and sells the dealer's customer at the same price he sells the dealer. This goes a long way to discouraging dealers from starting in business, and eventually if it continues will mean the complete elimination of the dealer in over 90 per cent of the communities, so far as radio parts are concerned.

Third, the elimination of the cut-price dealer in the larger communities who advertises standard merchandise at ridiculously low prices in the radio magazines, so that the country and small city dealers have no chance for legitimate competition, because as a rule, they have to pay as much for this merchandise at wholesale, as the retailers in the larger centers sell to the consumer for.

We believe that the manufacturer can stop all this if he wants to. If he does not do it, there is going to be a great reaction. Either the manufacturer will drive the retailer out of business, or the retailers will form an organization that will be country-wide, and will back the manufacturers who treat them right, and boycott manufacturers who use unethical methods of distribution.

Fourth, in every city that can support more than a few dealers, lines of merchandise should be exclusively with good dealers, as much so as in the automotive game. This will encourage the dealer and he will try to sell, whereas if everybody handles a line they do not attempt to move any more of the manufacturer's goods than a person offers to buy, and then it becomes a price proposition.

There is no question that these things are going to be done in the future, so why not start the ball rolling now in that direction? We believe all the missionary work should be done directly with the manufacturer, and if he is shown that he is not gaining one iota by improper and unethical business methods, we know he will try to do better, but so long as no one complains he will continue to get all he can.

We would like to hear from you on this subject.

A. GREENSPAN,
Radio Apparatus Co., Inc.
Omaha, Neb.

"Hastening the Weeding-out Process"

Editor, *Radio Retailing*:

The 1926 radio season presented some unusual situations. Unprecedented buying in October was followed by a sharp let-down in early November, due largely to unusually warm weather for the season. "Indian Summer" was the reputed cause for the slowing down of sales in other lines as well.

This slump during the first weeks of November was further aggravated by unsatisfactory reception due to the jamming of the air and the large num-

ber of stations within the receptive zone of the average receiver. This unexpected condition called for better, more selective sets than most manufacturers had provided. Thus a further hesitancy on the part of the buying public was brought about. Prospects wanted better sets than manufacturers had found it possible to produce.

Then, too, there was a general unwillingness on the part of the public to invest in anything—a general economic wariness. This puzzled radio manufacturers who had not experienced such temporary demand fluctuations. Others who had employed their manufacturing facilities in other lines were more fortunate.

The unusual trend of business in late 1926 will certainly have an excellent effect on the industry as a whole in that it will speed up the weeding-out process; cause a slacking of interest in radio by many of the smaller manufacturers, jobbers and dealers. Increased opportunity for the stronger, more able will be the natural result. Prospects for 1927 are bright. For those manufacturers who follow the trend of public demand; for those distributors who pay more attention to creating confidence rather than gross sales; for those dealers who realize their responsibilities to co-workers in the other branches of the industry—as well as to their own customers—radio holds a promising future.

A. H. BARTSCH,
General Sales Manager,
American Bosch Magneto Company.

Organization Needed

Editor, *Radio Retailing*:

Organization—plenty of it—is the crying need of the radio industry today. This is true of any branch that one may care to name. Broadcasters have shown a decided reluctance to get together; manufacturers allow petty, selfish interests to bar them from working together for the good of the whole industry; and lastly, the dealers themselves know practically nothing of the meaning of the word “organization.”

One has only to take a trip through the rural districts of the states to see this. In practically every town it is the same old story—unfair competition, price cutting, indiscriminate demonstrations of sets, and the hundred and one other little things that ruin business for every dealer in the community.

Take for example one of the towns which the writer happened to visit this past summer. The name of the town is unnecessary. This particular community has a total population of about eleven hundred people. Sixteen radio dealers were endeavoring to do business among this number of prospective customers. Each dealer carried from three to five different lines of merchandise. Each one hated the other—looked upon him as an enemy. They cut prices of standard sets. They made any number of demonstrations without making a single sale, merely trying to outdo competitors in generosity. They claimed the impossible for their various lines. Their advertising was exaggerated. Interference was rife in the town, but none of the dealers would do anything

about it, simply because he feared that it would help his competitor. They ran down each other's goods. Those who could not meet the price cutting on standard products, sold inferior goods, which could be bought for less than standard products and sold for less, retail, than the cost price on the standard material to the other dealers.

Anyone gifted with the least amount of imagination can see what the natural result was. The prospective customers in the trade territory held off buying. Some of them because they were waiting for lower prices—cut-rate prices. Others would never buy a radio set as long as they could have them in the house on “demonstration.” Many folks had a radio set in the house all winter without ever buying one. When one dealer took his set out after a demonstration, without making the sale, another would gladly grab at the chance of putting one in. Interference was so bad that those people who really owned receivers could get no enjoyment out of them. The general attitude of the public was that of distrust. And the dealers brought it upon themselves.

Now look at the other side of this question. Not far from this town was another community of about fifteen hundred population. This town boasted eight radio dealers. None of them carried more than two lines of sets. These dealers had formed a sort of club. They would meet every Monday and talk things over. Competition was keen, but it was clean. They exchanged information among one another as to the credit standing of customers. They adopted a policy for demonstrating. They would make a demonstration on deposit of ten dollars. An aerial would be put up and the set left installed for five days. At the expiration of that period, either the set was sold and the balance of the purchase price paid, or it was taken back and the deposit retained to cover the cost of aerial construction. Then a card record was made of the demonstration, and if the set was taken back, notation was made of that fact and the reasons therefor. This information was available to the other dealers, thereby shutting out the “demonstration hounds.” Every dealer in the town worked on the same plan.

Interference in the town was bad. The dealers held a meeting and decided to do something about it. They ran down the interference to the source. Discovered that it was caused by power lines, telephone ringers, motors and other electrical equipment. They went to the power companies, the telephone company, the owners of the trouble making equipment, and explained to them what was happening and asked for their co-operation. They got the co-operation and the interference was eliminated.

Then there was the matter of publicity. Each dealer took his turn at furnishing good radio publicity to the town paper. The newspaper ran it. People read it. Prices were maintained. And all on the strength of a “gentleman's agreement” on the part of the dealers to play fair and boost for radio.

These two instances are not fiction. They are absolute facts. And what a lesson in team-work is offered there!

The dealers who worked together increased business and all of them made money. The others destroyed the confidence of the public and all of them lost money and sales.

It costs nothing to shoot square with your competitor.

W. R. FRANK,
President,
Northland Radio Co.,
Minneapolis, Minn.

“Sell the Prospective Buyer Broadcasting”

Editor, *Radio Retailing*:

The great field today for the radio salesman is made up of people who do not yet own radio sets of any sort. These people are not primarily interested in buying receiving sets; what they will buy, if they buy anything, is broadcasting. Before the salesman can sell his particular type of receiving set, he has got to make the prospective buyer realize that he wants what the broadcasting stations have to give him.

The weakness I have observed in the work of most radio salesmen is that they do not realize that their main job is to sell broadcasting rather than a specific type of receiving set. There is no use trying to convince a man that he wants an XXX machine unless you have first convinced him that the broadcasting stations are sending out material which will be of service and pleasure to him. I have found very few salesmen who know anything about the programs on which their whole business depends, and I am quite sure that their selling efficiency is greatly curtailed by this ignorance.

A radio set is not like a lawn mower or an automobile or a sewing machine, which performs certain definite functions at the will of the owner. A radio set is absolutely useless except as the broadcasting stations give it material to work with, and unless the customer is definitely sold on radio programs, there is no reason why he should buy a radio set at all.

I believe that the future of radio retailing depends largely on the ability of radio salesmen to sell the idea of broadcasting. The radio stations are eager to co-operate, for more sales of radio sets mean more listeners for the stations. I believe that every radio retail salesman should make a point of getting in touch with the broadcasting stations which serve his territory, of finding out everything he can about their schedules and programs, and of putting himself in a position where he can talk intelligently to every prospective customer about the radio service which the station is prepared to give.

H. A. BELLOWES,
Manager, Gold Medal Station WCCO,
Minneapolis-St. Paul, and Regional Chairman,
Western Division, National Association of Broadcasters.

Editor, *Radio Retailing*:

Radio Retailing is a big help to the dealer as it offers many solutions to problems and offers many wonderful suggestions.

R. B. HENDERSON,
Detroit, Mich. R. B. Henderson Co.

He Made Service Pay

(From Page 42)

set-builders who were more or less mechanically inclined and who took pleasure in tinkering with their own sets. Most of our service then consisted of giving advice right here in the laboratory. But radio is no longer a novelty and, while there are still many builders, the class of people who buy radio sets is quite different. Now they don't want to have to do a thing except tune in and sit down to enjoy the program. They don't know anything about the mechanical features of their sets and they don't care to learn. They won't take the trouble, even, to master the simple details of operating the sets. The result is, we are constantly getting service calls that seem ridiculous. The batteries are not connected up, they twirl the dials around and can't get reception, or anything imaginable is likely to be the cause of a service call. 'Let the dealer fix it; if we monkey with it, we may get it out of whack sure enough,' seems to be their attitude.

"We install every set we sell and we go to great pains to instruct the owner in its proper use and care, but some of them certainly fail to profit by our instruction. That's all in the business, however, and we emphasize cheerful service, no matter what the circumstances. The demand for more and more service is really becoming a problem, though, and I frankly can't see how the dealers who operate on a cash-and-carry basis, with no service whatever, can continue in business. I don't believe they can continue in business in smaller cities and towns, where the amount of new business is limited. In a big city, there are always many people with whom price is the first consideration, of course, and the cut-rate dealers can keep attracting new customers by their price advertising.

"Our business is increasing steadily, even at a time such as this, when the cut-rate places are advertising nationally-advertised sets at one-third regular prices and even less. We haven't found it necessary to unload yet. We have found that our net profit on sets is too uncertain, due to the amount of service required, to permit cutting prices under any circumstances. Of course, if we didn't give service, we could sell at a discount but we believe that service is more important than price,

particularly in a reputable store that is undertaking to build business for the future, as well as for the moment."

Serlin and Company sells on a time-payment plan, but insists on a minimum of one-third down. In this policy too, it has made a change based on experience. The management used to be of the opinion that it should reduce the amount of the down payment during the dull summer months in order to stimulate business. Now it goes to the other extreme and increases the down payment to 50 per cent in the summer. The reason for this is, Mr. Serlin explained, that people are outside so much, and take so little interest in radio during the summer that they are more likely to turn a set back

on the dealer than during the winter, when they are inside more and getting more enjoyment from their sets.

In line with the general policy of the store, Serlin's doesn't guarantee distance with any set. "We tell customers that owners have gotten such and such stations on similar sets," Mr. Serlin said, "but that we don't guarantee any set to get any station outside the city. Too much depends on the operator and on conditions, such as the aerial, location, and so on. We have learned from experience that it pays to be ultra-conservative in selling radio."

So Serlin of Detroit—the man who couldn't make price-cutting pay, is putting it over on the basis of service!

How times have changed!

Automatic Switch Turns Radio On and Off After Store Has Closed

Vallejo, California, is the home of a radio dealer, L. N. Messenger, who makes an automatic "time" switch work for him after the store is closed. Messenger has mounted a cone-speaker, varnished to prevent deterioration, over the entrance to his shop at 342 Virginia Street. Leads from this speaker run inside the store to the output jack of a power-amplifier and B battery eliminator which is in turn connected to a five-tube radio receiver.

One of the automatic switches in a double-pole "torque" clock is connected in series with the set's A battery while the other, working in unison, is connected in the electric light line which supplies the store window's flood lights with power.

When Messenger closes the shop at night he tunes the receiver to the wavelength of a local station, sets the clock "on" switch for 7:30, the "off" dial for 10:30, locks the store and goes home. Promptly at 7:30 the clock turns on the window flood lights and then starts the receiver. The broadcast program continues until 10:30, when the

clock again turns the store lights off and disconnects the receiver. The tube tester shown above the "torque" clock in the insert is not connected in any way with the time circuit.



At 7:30 p.m., the time switch in the enlarged insert turns on window flood lights and starts set.

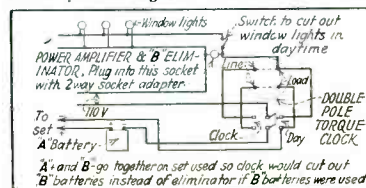

For the Service Department



A monthly department for the dealer, service man, and salesman.

Conducted by
H. W. BAUKAT

Visible Card System Prevents Errors

ONE of the perplexities the radio dealer has to face is the ease with which service appointments are overlooked. The Youngstown Radio Shop, Youngstown, Ohio, has solved this problem with a service card appointment holder which visualizes each assignment by the day and shows which service man is taking care of it.

This holder is made of metal and is divided into seven horizontal and six vertical compartments. The seven horizontal rows corresponding to the seven days of the week and the six vertical to the five service men and the service repair bench. The service men are designated A, B, C, D and E, starting from the top.

When a call for service is received over the telephone, it is written out on the service card and filed according to the day promised and the service

man at liberty or qualified for the particular job. By referring to the illustration above, it will be seen that Monday's work is all cleared up, and that only service man A has some back work for Tuesday. This photograph was taken on a Wednesday noon. It will be seen that the service department (lower row) has a number of assignments and also service men A, B and E. The number of future service calls are also quite evident at a glance. The convenience of a large-size map of the city near the board is apparent.

An individual service record is kept for each customer. An alphabetically arranged card record of persons who purchase their sets from the Youngstown Radio Shop is also kept. Service cards of persons who purchased their sets elsewhere are kept in a separate file. Use of a system such as this makes a very favorable impression upon customers and is a time saver for the dealer.

Lining Up the Dials

A customer recently complained to his dealer that his tuned radio frequency set did not read alike on all three dials. The second and third dials agreed but the first one differed notably. The dealer tried at first to explain to him that the aerial naturally threw the first dial reading off and that the fault was not with the receiver. The customer was not satisfied,

Name <i>J. B. Browning</i>		Phone <i>6-38</i>	Set <i>R. C. L. 85</i>	SERIAL NO.	
Address <i>35 Elm St.</i>		Model <i>Dec. 25th</i>	<i>Price Radio Co.</i>		
Occupation <i>Bank Cashier 1st National</i>		Prospect for <i>6 Tube Amplifier</i>			
DATE	TROUBLE REPORTED	TROUBLE FOUND	DATE REPAIRED	BY	NATURE OF WORK, REMARKS
<i>6-3</i>	<i>Howling</i>	<i>Jude Lopez</i>	<i>6/3-25</i>	<i>J. B.</i>	<i>new socket</i>
<i>7-1</i>	<i>weak</i>	<i>B. Battery</i>	<i>7/1</i>	<i>J. B.</i>	<i>2 "B" Batteries</i>
<i>10-11</i>	<i>Out of off</i>	<i>set loosened</i>	<i>10/15</i>	<i>J. B.</i>	<i>sold him a 6-amp</i>

Service work is greatly facilitated and chances of error minimized with the card holder here described which uses cards similar to the one above

however, and insisted on having the defect remedied. Here is how the dial was made to agree with the other two.

A .001 mfd., variable condenser was connected in series with the aerial placed in back of the cabinet where it would not be seen. By adjusting this condenser to the proper value the reading on the first dial was made to agree with the other two. After the value of this condenser is once found it need not be changed at all.

In some cases it will be found that even a still larger condenser will be necessary in order to bring the readings together. A fixed mica condenser of some small value can then be placed directly across the variable until the desired results are obtained. Very little loss of volume if any will result and as a rule the receiver is made more selective by the use of this condenser.

Radio Shop Issues Service Contract

Henkel's Radio Shop, Lansing, Mich., issues the "service contract" illustrated below, with every receiver sold. To avoid confusion and misunderstanding in the customer's mind concerning just what and how much service he is going to receive, the contract goes into minute detail, listing precisely what the customer is to expect in the way of service. For a flat sum yearly (\$10), the customer will have his set serviced once a month, emergency calls to be charged for at the minimum rate of \$1 per call. On the reverse side of the duplicate contract retained by the store,



Removing dents and scratches from highly polished cabinets with a "shellac stick" by the aid of a spatula and an alcohol lamp

space is marked off for complete information about the set and owner, and for a record of the calls made and work done.

Ugly Dents and Scratches in Cabinets Easily Repaired

Sometimes expensive cabinets will get scratched. Little pieces are chipped out of the surface of the wood here and there. This does not, of course, affect the quality of the radio from an electrical standpoint, but it does make it hard to sell the particular cabinet.

A substance known as a "Shellac Stick," resembling in appearance ordinary sealing wax can be used to fill up defects of this kind, with astonishing results. These sticks can be procured from paint supply houses in a wide variety of colors, matching the usual shades and finishes of wood.

The easiest way to use the preparation is to light a small alcohol lamp,

as shown in the photograph, heating an old table knife, or spatula, and holding the stick right over the defect in the wood, carefully fill up the blemish. Then smooth off even with the surface. A little practice will show how long the knife should be held over the flame so that when it is pressed against the shellac stick, it will melt, but not burn out the color. After this is done rub the surface carefully with polish and the cabinet will be restored to its original finish.

Wet Tree Branches Cause Interference

Tree branches that are either wet or ice covered coming in contact with power lines, where the insulation on the wire has been rubbed off, create small arcs. This is very annoying to radio reception in the near vicinity. Watch for such leaks and report them to your local power company, which is always glad to know about them.

Service Charge Includes Clean Up

Here is an idea which makes the service charge less objectionable to the customer. One company in New England makes a regular service charge of \$1.50 for each call. This is what the service man does and it may easily be seen that the customer is getting his money's worth even if the call was made for just a minor trouble. To start with, the storage battery is tested; a piece of heavy sand paper is then used to clean off the terminals and shine them up; and finally a little vaseline is rubbed on the terminals to prevent corrosion.

The contacts and wires for connections are gone over and replaced where it is advisable. The B battery

Date.....	HENKEL'S RADIO SHOP		Expires.....	
Agreement Begins.....	125 West Washtenaw St.	Lansing, Mich.		
	RADIO SERVICE AGREEMENT			
	In consideration of the service to be rendered by the			
	HENKEL'S RADIO SHOP			
hereinafter called the company, in connection with the correct operation of.....	Radio Set			
Style.....	Ser. No.....	I hereby agree to pay the		
sum of.....	Dollars (\$.....)	payable as follows:.....		
This agreement does not cover the replacement of tubes, batteries (including recharging of storage batteries), ear phones, loud speaker or any other part. The Company agrees to put the above described instrument in correct operating order, if needed, at or near the date of beginning of this contract, and to give the following service for a period of twelve (12) months from said date.				
Antenna	INSPECTION OF	Tube Sockets	This Agreement is not to be confused with the Manufacturer's Guarantee, which does not cover service, but guarantees material and workmanship only. Defects that might arise from lack of proper care of this instrument are not evidence of poor material or workmanship.	
Ground	Resistor	Filament Switch		
Lightning Arrestor	Potentiometer	Batteries		
Loop	Transformers	Tubes		
Jacks	Inductances	Selectivity		
Condensers	Crystal	& Etc.		
	Battery Connections			
To make twelve (12) voluntary inspection calls from Radio Service Department, calls to be approximately thirty (30) days apart, and to respond to emergency service calls on the basis of \$1.00 minimum per call. Service men to receive and report to office any and all suggestions for the betterment of this service.				
Damage by fire, water, action of the elements, or accidental or malicious injury is not covered by this agreement.				
Accessory Equipment: Tubes..... Loud Speaker..... Console Speaker.....				
Phones.....	A Battery.....	B Batteries.....	C Battery..... Loop.....	
Signed..... 192.....				
Address..... Res. Phone..... Bu. Phone.....				
Accepted..... 192..... (Dealer)				
By.....				

A well-written contract such as the above makes the servicing of radio sets a much easier and more pleasant business

is given a test, or if an eliminator is used, the voltages checked up. The tubes are removed from the socket and the prongs are cleaned with sand paper as are also the tube prongs. A milliammeter is placed in the B lead and each tube is tested for emission. The tubes are then replaced in the sockets where they work best.

The ground connection is given a cleaning and the antenna installation looked over. The insulators are cleaned and the wire tightened up. This sounds like a lot of work, but in reality, if it is done systematically there is very little time consumed. Should the service man find extensive repairs needed, a correspondingly higher charge is made.

Radio-Equipped Auto Traces Interference

A compact service car for the location of radio interference troubles has been equipped by the Portland Electric Power Company of Portland, Ore. The equipment has been mounted on an automobile in such a way as to be especially flexible in use and convenient to the operator of the car.

The receiver is 21 by 7 by 6 inches in size and is strapped to a shelf at-

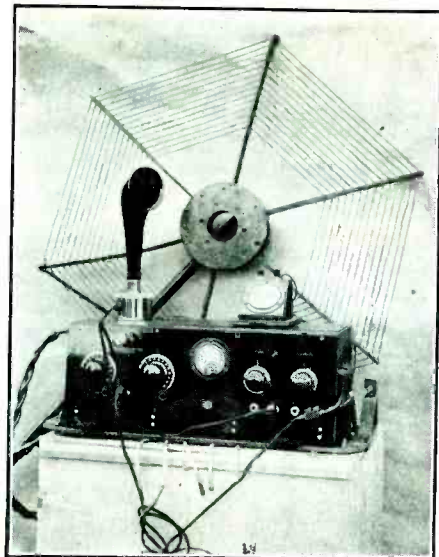

Here is the 10-tube set together with the loop, horn and thermo-galvanometer, used by the Portland Electric Power Co., for tracing radio interference.

tached to the dashboard of the machine, so as to be within easy reach of the operator of the car. A slight modification of a super-heterodyne circuit is used. The simplicity of operation is another factor of importance, the adjustment of two dials being all that is necessary.

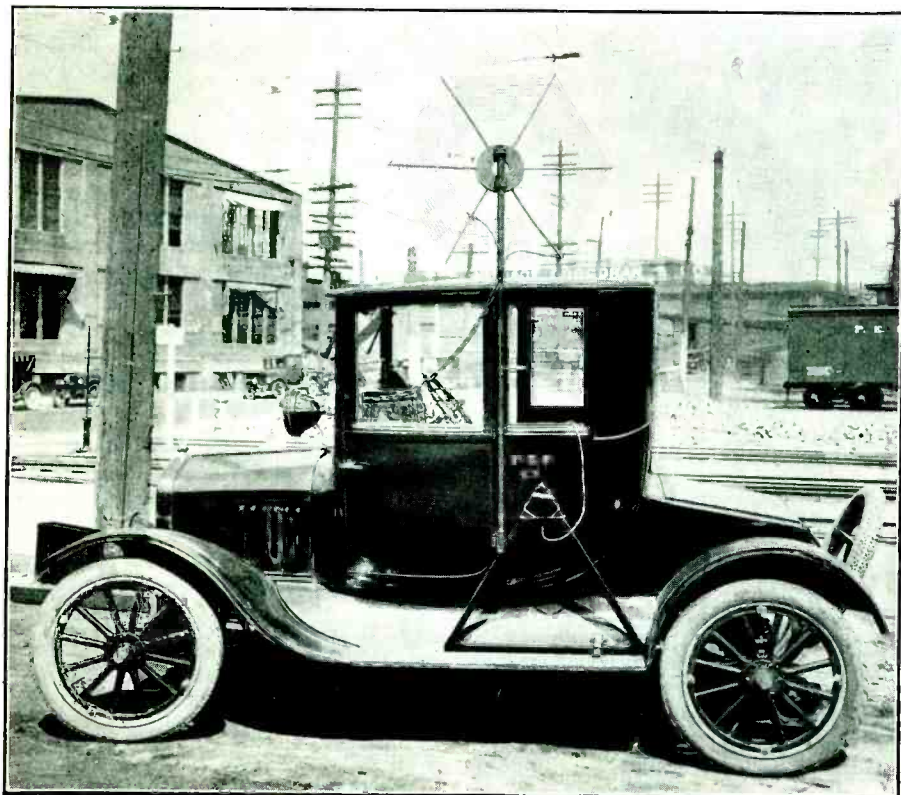

The Portland Electric Power Company, Portland, Ore., is doing excellent work in tracing down and eliminating interference with radio reception in the section around Portland. By means of the radio-equipped auto pictured above, it is possible to find the exact location of the disturbing noises.

A loud speaker fitted with a small rubber horn is mounted in the rear corner of the car behind the operator. The condition of the receiver, the strength of signal and other important information are tested by means of a thermo-galvanometer which is connected through a transformer with the receiver.

The loop is hexagonal in shape and consists of braid covered enameled wire mounted on bakelite spreaders and is mounted on a short mast supported from brackets on the left door hinges. This enables it to be swung in any direction by the operator of the car, while at the same time, it does not interfere with the free movement of the door. All connections to the receiver are made so that the entire equipment may be disconnected readily and removed from the car.

Exploring Coil Used

A triangular frame mounted on the running-board bears some two thousand turns of wire which, when connected to the audio amplifiers of the receiver, serves as an exploring coil and enables the operator to follow overhead and underground lines upon which a given signal has been imposed, or upon which there is a flow of current. A smaller coil, rectangular in shape, is used in distinguishing which of several lines is the one responsible for the current causing the interference. Grounds in trees, poles and other trouble spots are also located in this way. An audio frequency signal or disturbing noise often indicates the immediate vicinity of the source of the interference. The radio receiver gives the general location and the exploring coils permit a narrowing down of the possibilities and the ultimate tracing of the exact source.

A and B batteries are carried under the seat of the car.

The receiver is shielded from interference from the electrical equipment on the car by means of 20-gauge brass. The disturbance which still remains from the ignition spark is obviated by a push-button switch arrangement mounted on the steering wheel, which makes it possible to cut off the ignition temporarily. Ten UV-199 tubes are used in the set, no microphonic noises from this source having been observed.

The arrangement is extremely flexible and satisfactory in operation and has done much to eliminate radio troubles in the Portland district.

Audio Frequency Amplifying Units

In the first group below are audio amplifiers which use the same battery supply as the set. The second use 110-volt house current and in some cases are also B socket power units.

Audio Frequency Amplifiers

Manufacturer's Name and Address	Trade Name	List Price	Number Tubes Used	Type of Tubes To be Used	Type of Socket	Over-all Dimensions in Inches	Type of Coupling	Filament Control Provision
Alden Mfg. Co., Springfield, Mass.	Truphonic	\$25.00	3	3-201A, 1-Hi-Mu 1-201A and 1 Power, or 2-199 and 1-120	UX	12½x2½x2¼	Combination Transformer and Double Impedance	Rheostat
Allen-Bradley Co., Milwaukee, Wis.	Bradleyamplifier	15.00	3	2-201A or Hi-Mu and Power Tube	UX	9x3½x2½	Resistance	None
American Specialty Co., Bridgeport, Conn.	Kelford	8.00	3	201-A	UV	9½x3½ base	Resistance	None
Daven Radio Corp., Newark, N. J.	Daven	15.00	3	2 Mu-20 and 1 Mu-6	UX	10½x3¼ base	Resistance	Not Necessary with these tubes
De Jur Products Co., New York City	Planofier	8.00	3	2-201-A and Power tube	UX	8½x3¼ base	Resistance	None
Mountford, C. E., New York City	Mountford RC 30	6.50	3	201-A	UX	10½x3½x2	Resistance	None
Muter, Leslie F., Chicago, Ill.	Muter	6.00	2	201-A or Hi-Mu	UV	7 x 3½ base	Resistance	None
	Muter	8.00	3	201-A or Hi-Mu	UV	10½x3½ base	Resistance	None
Pentz Radio Factory, Minneapolis, Minn.	Pentzlyne	7.00 to 14.00	1 and 2	201-A, Hi-Mu or Power	UV	Various-In small cabinets	Transformer	Rheostat and switch
Sonatron Tube Co., Chicago, Ill.	Sonatron	20.00	3	Hi-Mu, 30, 20, 6	UX	Resistance	Switch
Trelcott Co., Louisville, Ky.	Trelcott	7.00*	1	B. M. 201-A	UX or UV	7x6x3	Transformer	Switch

Note—In all cases —B is connected to +A *Price includes tube.

Power Amplifiers

Manufacturer's Name and Address	Trade Name	List Price†	Voltage and Frequency Used Volt Cycle	Can Be Used As B Eliminator	Voltages Supplied	Type of Tube Used for Rectification	Type of Tube Used for Amplifier
Freshman Co., Chas., New York City	Freshman	\$50.00‡	110 60	No	UX-216-B	UX-210
General Radio Co., Cambridge, Mass.	General Radio	68.00	110 60	Yes	45, 90, 180	UX-213	UX-171
Graybar Electric Co., 100 E. 42d St., New York City	Western Electric 6925 B Western Electric 6031 B	115.00 160.00	110 60 110 60	No No	205 D 104 D	205 D 104 D
Martin, Glenn L., Cleveland, O.	Standard Amplipower Special Amplipower	49.50 80.00	110 60 110 60	Yes Yes	10-125 10-125	Any 5 volt tube Any 5 volt tube	UX-171 UX-210
Pacent Radio Corp., New York City	Powerformer	82.50	110 60	Yes	80-90, 135	UX-216-B	UX-210
Radio Corp. of America, New York City	RCA-AP935	105.00	110 60	No	UX-216-B	UX-210
Radio Receptor Co., New York City	Powerizer	49.50	110 60*	Yes	Det. and Amp. Variable to 150	UX-216-B	UX-210
Timmons Radio Prod. Corp., Germantown, Philadelphia, Pa.	Timmons Timmons	45.00 70.00	110 60 110 60	No Yes	22, 45, 67, 90	UX-216-B UX-216-B	UX-210 UX-210

* Also 25, 40 or 50 cycle at any voltage. † Without tubes. ‡ With tubes

How to Make Quick Circuit Tests

Tests for open circuits without taking the receiver apart can be made with a very simple, easily constructed piece of apparatus. An old vacuum tube base is used for the purpose of making contact in the socket. The glass is first removed and then a flexible lead about two feet long is soldered to each one of the contact pins inside of the base. It is best to use a different color wire for each lead. This brings out the plate, grid and filament contacts of the tube socket. By placing a pair of head phones or voltmeter and

a battery in series a complete circuit will be shown by the movement of the meter arm or by the click in the phones.

In the two radio frequency tubes a closed circuit should be shown between the grid lead and the negative filament, and an open circuit between the plate and either filament. The detector tube should show an open circuit on both these tests. The first and second audio tubes should show a complete circuit between the grid and negative filament and an open circuit between the plate and either filament.

The plate circuit may be tested in

each case for continuity by placing one lead of the battery on the B binding posts supplying the particular tube socket under test. This method saves considerable time for the service man and the test can be included easily in the regular procedure.

Choke Coil Construction

A good type of choke coil to be used in connection with condensers for eliminating interference in power lines from small motors consists of 100 turns of No. 18 double cotton covered wire, wound in a single layer on a fiber tube of about 3 in. diameter.

Know Your Business at a Glance

(From Page 50)

After the previous day's transactions have been transferred to their proper places, with the aid of an intermediate collating sheet if desired, the morning's mail is opened and the incoming checks (if any) and bills (there will always be found plenty of these) are listed and entered on a memo pad for totalling and recording.

Further detailed suggestions as to the keeping of these records would be confusing. This, after all, is best left to the special requirements of each dealer's business and may be readily worked out by each individual from a study of the accompanying illustrations and the classified listing.

Rate of Progress and Present Position

The question now arises: "Are all these records necessary?" Baldwin's success confirms my own opinion that they are. They form a continuous and connected story. They are a part of two dominating thoughts—the compiling of a monthly profit and loss statement and the accurate determination of assets and liabilities. The former will show the *rate of progress*, the latter the *present position* of the business. From a study of the profit and loss sheet, therefore, will come a knowledge of the course to be charted if the ship is to be speeded up and the snags of last month's passage avoided. From the latter statement is derived information concerning the firm's stability. Bankers require such a presentation before loaning money, and time payment companies, also, before purchasing contracts.

Less Than 14 per Cent of Total Expenses Controllable

But there is still another reason justifying these records. On the average less than *fourteen per cent* of total expenses are controllable. When it is considered that the degree of success or failure, of profit or loss, which the retailer will have is confined within the narrow bounds of that fourteen per cent—or less—the merchant must realize the need for accurate, complete and informative records.

In that Illinois town where Abraham Lincoln practiced law for many

years, and where he built the legal reputation and skill that sent him to the White House, there now resides a dealer in radio exclusively who has averaged a net profit of seven per cent a month throughout the year on a gross volume of but \$23,000 because he has realized the importance of business control—of locating the petty leaks in time to prevent their development to disastrous proportions.

1927-1928 Trends in Cabinet and Circuit Designs

(From Page 37)

marketed, and others are planning to market, receivers in two units, each unit embodying some part of the circuit, as, for instance, the tuning unit small and compact so as to be easily carried from room to room, while the amplifiers and battery units remain stationary. Others incorporate the speaker and eliminator in one unit separate from the set and have found it readily marketable.

Long Air Column Speaker Becoming Popular

Furthering this trend toward separation, is the fact that long air column speakers, approximating 96 inches, are finding increasing popularity with the public because of their deep, rich tones, and to build horns of this type into the same cabinet with the set and batteries or power units, often results in a bulky, unwieldy job, expensive, difficult to ship, and not as popular as the smaller consoles.

The vibrations caused by a too close proximity to the circuit are said to be less pronounced with air column type speakers than with cones, although several manufacturers are successfully building cones inside of their consoles with no appreciable disastrous results.

Manufacturers are waiting for the trade to express its opinion on these questions and the trade can provide its manufacturers with some valuable information if it will answer them—

Will the public readily accept the console and speaker separation if better reception results? Will the increasing popularity of long, air-column horns have an appreciable effect on the sale of cones?

Separating Those Who Buy from Those Who Talk

(From Page 53)

later pass it over to be carried out by the mechanical department, but the customer applies direct to this department, handling his own business in another part of the store, adjoining but perfectly distinct from the sales section.

A booth is provided, similar to an information desk or cashier's window and here a clerk is always to be found who not only can answer questions as they come up, but is in constant touch with the service men in the field, so that any inquiry can be answered promptly. Six service men are kept continually busy in the field.

Contacts After Set Is Sold Come Under This Department

When a set is sold, it is turned over to this department and from this time on the customer's relations are entirely with this personnel. He pays his installments at this window, and here he comes for service or to ask advice or to make arrangements for overhauling his equipment. The service man takes the set into his home and installs it, calling later to see that it works properly, and incidentally collecting new leads.

The regular salesman does not go into the field, all sales being made on the floor of the store. Of course, considerable advertising is done in the newspapers and direct-by-mail appeals go out to the full list of the store's clientele from time to time.

The result of these methods has been a very large volume of business handled in a small floor space with no very large staff of salesmen.

And yet the sales floor does not give the impression of hurry, or of impatient waiting on the part of unserved customers. This is because all extraneous business not directly associated with selling has been directed elsewhere. A line may form in front of the service window with no serious results, because each of the persons in it is there to ask a favor and is willing to wait. But let a line form behind a clerk who is selling radios, a line of prospective customers each of whom feels that he is about not to ask but confer a favor, and the result is inevitably sales lost. In the separate service department the Meier and Frank Company feels that it saves the salesmen's time and money and expedites sales, thereby increasing them.

Radio Retailing's Monthly Section of
Sales Ideas in Pictures



The Cleveland Radio Supply Company of Oakland, California, attributes its \$150,000 annual radio business to the efforts of one outside salesman backed by a store of distinctive appearance. The store fairly radiates individuality and is one of the most attractive on the Pacific Coast

How Outstanding Radio

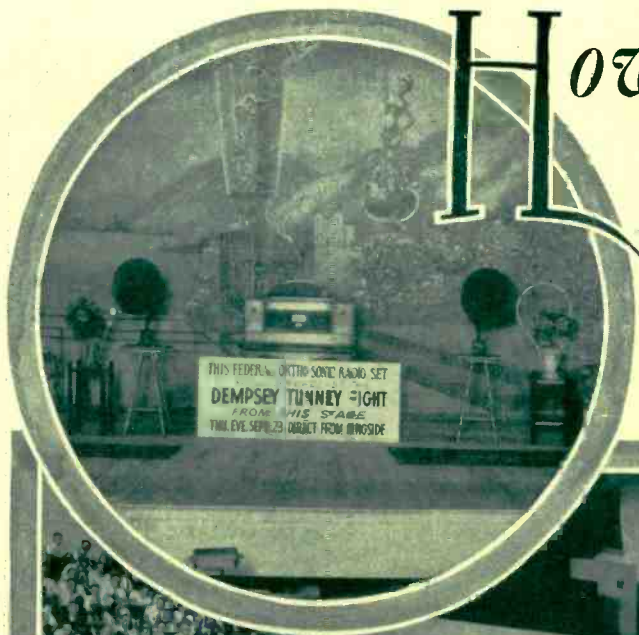

Timely exploitation of sport events and concerts leads to added sales



Left—R. E. Torque Co., Philadelphia, broadcast from the stage of a local theater the big fight.

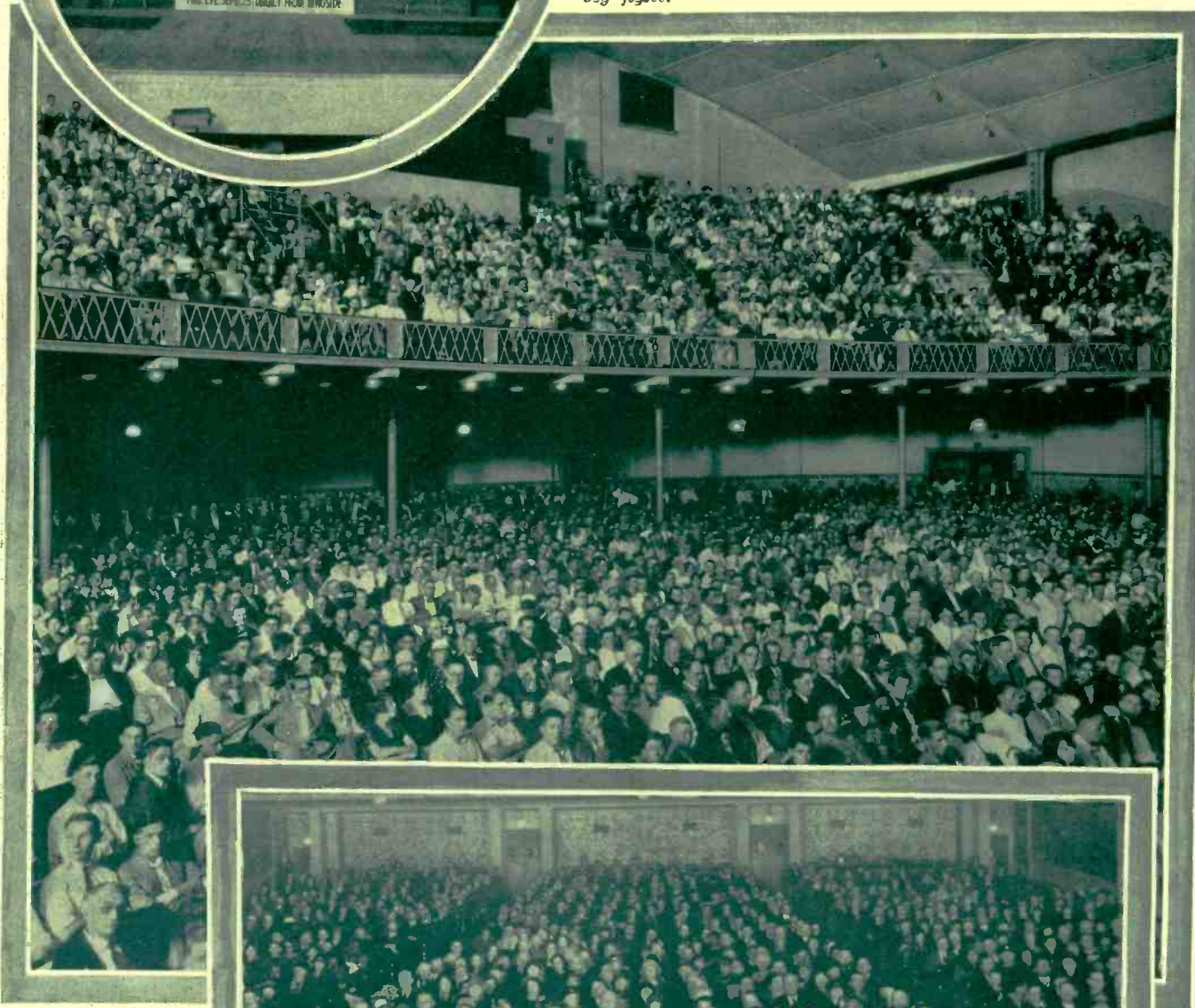

Above — How the Day-Fan Electric Co., Dayton, O., filled Memorial Hall, Dayton, for the fight returns.



Above—The Northwest Radio Trade Association rented the Lyceum Theater, Minneapolis, and staged a free radio show before a capacity house of 2,000

people on New Year's Night to hear the John McCormack concert from New York which was rebroadcast by WCCO, Minneapolis.

Programs Are Being Merchandised

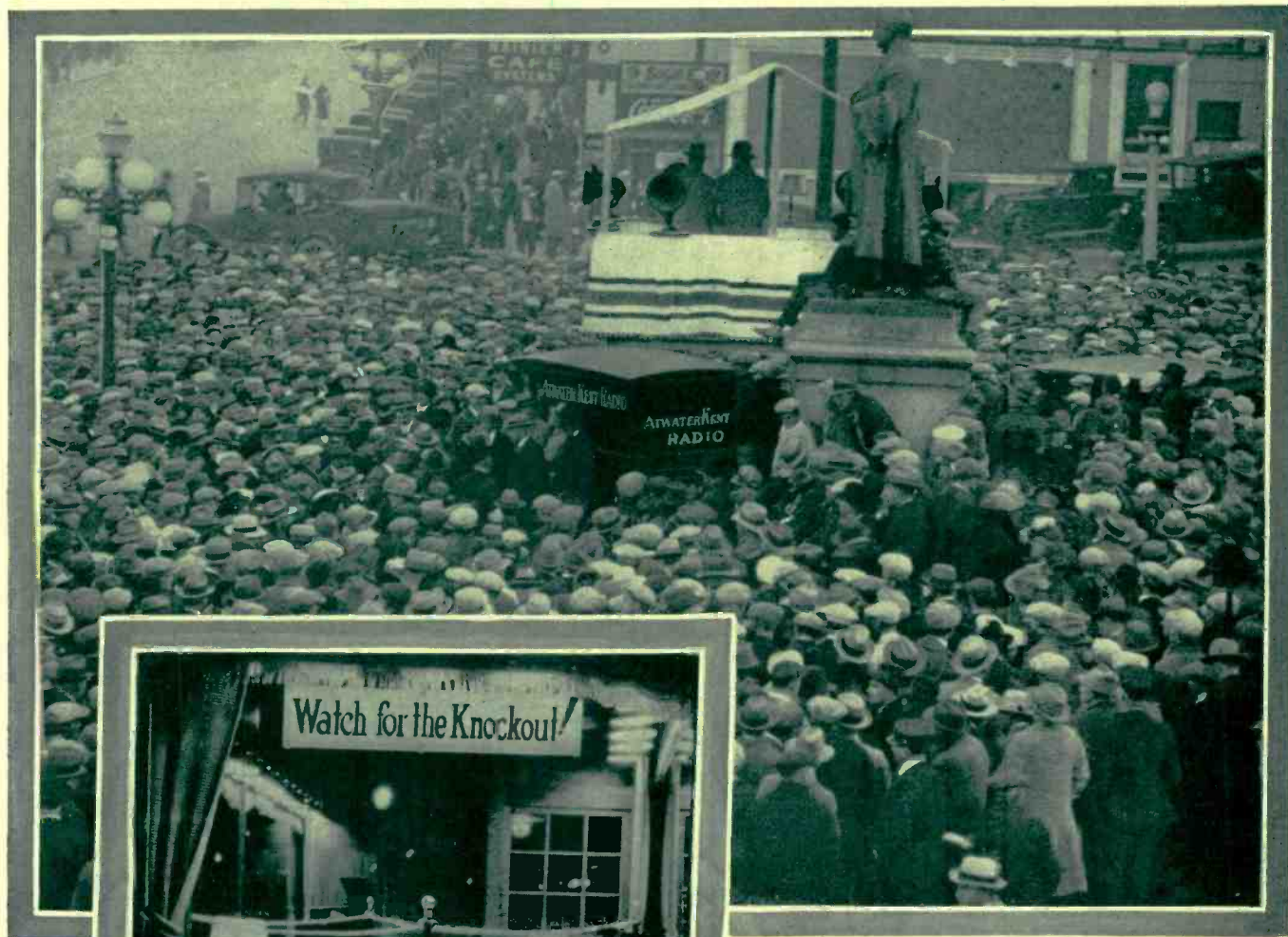

Above—The *Sunset Electric Company*, Seattle, Wash., broadcast the *Dempsey-Tunney* fight in Times Square, Seattle.



A miniature ring in its window display, with a receiver nearby was used by the *Wright Music Co.*, Cleveland, to tie in radio with the broadcasting of the *Dempsey-Tunney* bout.

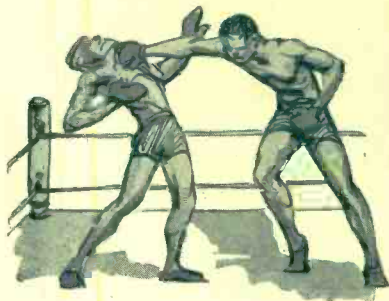

Above—The *Radio Reception Studio*, Hollywood, Cal., broadcast the *World Series* through *Stromberg-Carlson* receivers as well as recorded the plays on the scoreboard. Other outstanding pro-

grams which may be similarly exploited are being broadcast regularly. Are you taking fullest advantage of the merchandising possibilities they offer, as the dealers cited on these pages are?

Forest Grandeur Enriches

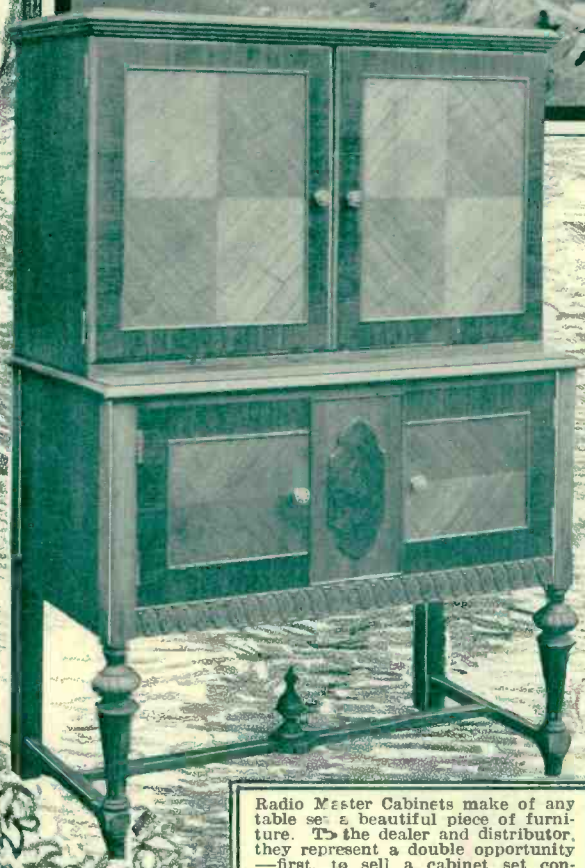

Radio Master Cabinets make of any table set a beautiful piece of furniture. To the dealer and distributor, they represent a double opportunity—first, to sell a cabinet set containing the radio you consider the best—second, to sell cabinets to owners of table sets.



Man's Triumphs

IN THIS great factory, stretching along the Saginaw River, forest giants become beautiful radio cabinets—beautiful furniture.

From the trees cut by our own lumberjacks to the splendid finished product, almost every operation is conducted under the supervision of the Ward Industries. Logs are brought by rail to our own sawmill, where they are sawn into timber or "peeled" or sliced into veneer—for the making of plywood—seasoning—kiln drying—are all done in our factories.

When the lumber and plywood are ready, our artist craftsmen—virtuosos in wood—make them into Radio Master Cabinets. Radio Master Cabinets have enriched man's latest and most startling triumph—the radio, helping to make it a delight to the eye as well as the ear.

With the capacity of a million feet of lumber a month, we supply fine lumber and plywood, not only to our own cabinet factory, but to others throughout the country.

A big factory where things are done in a big way—where nothing is allowed to stand in the way of craftsmanship—of uncompromising quality in all products.

Relations with customers are conducted on the high plane such a factory would lead you to expect. Our dealer and jobber policies are fair—arranged to allow excellent profit. They are definitely fixed, so that no customer receives to the least degree any advantage over any other.

You will find Radio Master Corporation a most satisfactory firm with which to deal—hundreds of others have found it so.

RADIO MASTER CORPORATION



H. KOLP

Striking Displays that Stopped 'em!

Tying Up Radio with the Movies

How a radio window display may effectively co-operate with a moving picture feature shown at a local theater is illustrated in this window (right) of the Helbrung and Grimm Furniture Store, St. Louis. The showing of the "Black Pirate" was the occasion for this display which shows a radio set on a miniature steamer.

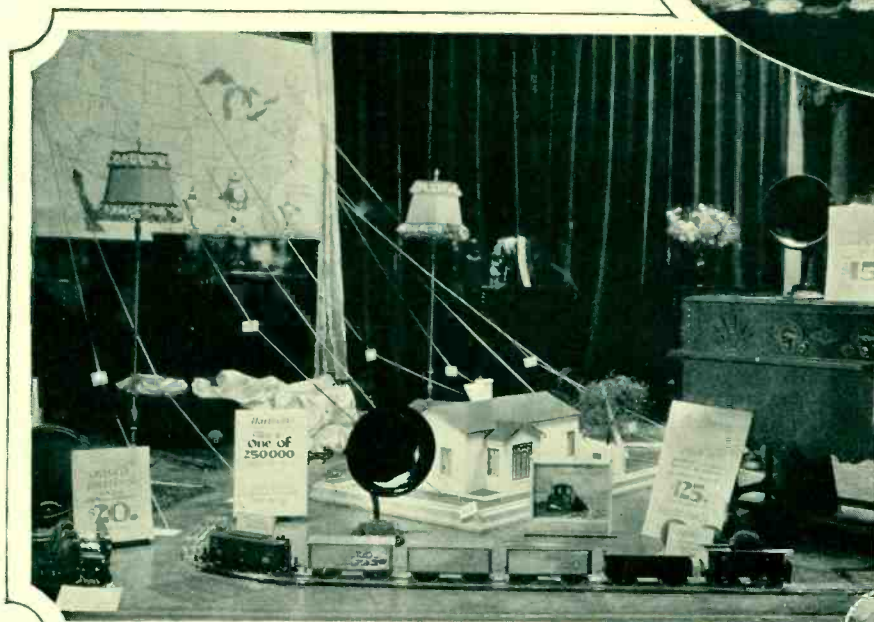

"Carload Just Received"

The window exhibit at the left shows how Hartman's Furniture Company of Chicago got across its announcement "A Carload of Radios Just Received." The toy electric freight train running around a miniature bungalow kept the space in front of the window crowded. Attention was drawn to the principal stations that can be heard in Chicago by ribbons attached to a large wall map and centering on the bungalow.

Visualizing Radio Programs

Radio programs are "visualized" in this window, right, of the Empire District Electric Company, Joplin, Mo., by draping white maline as flowing out of the loud speaker. On the maline are placed cut-outs of famous radio artists.

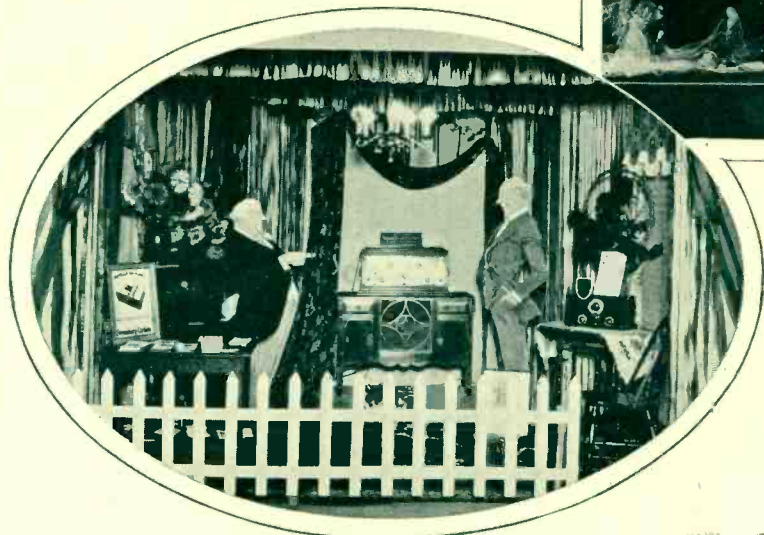

Smiles and Radio

Genuine happiness—as expressed in the broad smiles of these two cut-out figures—has radio as its basis. That is the evident message of this novel exhibit, shown at the left, of Henry Worthington, a Coshocton, Ohio, dealer, at a recent county fair. This is a type of display that is effective and inexpensive and can be used in windows as well as in an exhibition booth.

Sales Letters That Carry a

Unique Personal Appeal

Independent Radio Sales, Inc.
616 SOUTH MAIN AVENUE
EXCLUSIVE RADIO
SIoux FALLS, S. D. Aug 7, 26. PHONE 997

G. I. MORGAN
PRES. AND GEN. MGR.

TO: Mr. Thomas Lucas
65 James St.
City

Authorized Dealer
RCA

Dear Mr. Lucas:

Is it a fact that there is about radio a never falling lure? Somehow one never seems to tire of turning those little black disks and of listening to entertainment from the four points of the compass.

Take the prominent Rotarian whose countenance smiles at you from the attached clipping for example. I feel quite sure that he would agree with the truth of this assertion—if he would but permit us to demonstrate the fascinations of radio reception to him.

What do you say to this, Mr. Thomas Lucas?

Our phone number is James-258.

Sincerely Yours
G. I. Morgan
President



Independent Radio Sales, Inc.
616 SOUTH MAIN AVENUE
EXCLUSIVE RADIO
SIoux FALLS, S. D. AUG 7, 26. PHONE 997

Authorized Dealer
RCA

To Mrs. Guy Fairweather
49 Lincoln St., City

This charming bride should have a radio set. Now-a-days the little nest is not considered properly "feathered" unless this "music box of magic" occupies its rightful place therein.

Now is the time to buy, Mrs. Fairweather. Right at the start of life's greatest adventure. Give yourself every minute you can get to enjoy this modern blessing. Our phone number is James-158.

Sincerely Yours
G. I. Morgan
President



It would be difficult to conceive a more striking method for gaining immediate attention than to attach the reader's picture to a sales letter containing a personal reference.

WHY that's me! I must see what's in *this* letter." And that is exactly what G. I. Morgan of the Independent Radio Sales, Inc., Sioux Falls, S. D., wants his prospects to do. Morgan is gaining this more than usual attention from those to whom he addresses his "personalized" letters because each one applies only to the recipient and because this "self-interest" text is typed around a clipped photograph of the individual to whom the letter is addressed.

Each Sales Letter Sounds a Personal Note

Wouldn't you be more than ordinarily impressed if, when opening the day's mail, you came across your own well-known features attached to this:

"Take the prominent Rotarian whose countenance smiles at you from the attached clipping for example. I feel quite sure that he would agree with the truth of this assertion—etc."

Mr. Morgan states that he is hearing from the majority of those

to whom such letters are sent. Owing to the nature of this direct-by-mail promotional stunt, it is not possible for him to prepare more than six or seven of these missives a week. "But, believe me, it's time well spent," he says.

Here is Morgan's method of procedure:

He scans the local newspapers and other sources such as souvenir programs for personal items which are accompanied by a cut of the man or woman to whom they refer. He clips articles of this nature and places them in a special file. Then, at the first opportunity, he prepares a letter in which some personal mention is made about the person to whom it is addressed.

The specific information for each letter is readily obtained from the publicity which he has clipped. As shown by the accompanying illustrations, the portrait of the prospect is carefully pasted on the letterhead. Newlyweds and substantial members of his community are the ones singled out for this attention.

This task is not so arduous as

might appear at first glance because the body of the letter follows a set form. One or two lines only are required to give it the personal touch.

Mr. Morgan hears from over 50 per cent of all those to whom he writes, and the proportion of sales that follow this unique scheme is large. Other dealers might find it just as helpful.

Sign Attracts Customers in Cold Weather

A sign reading "Come On In And Get Warm" has been very effectively used by the Arrow Radio Company, 60 Warren Street, New York City. According to J. Schonbrun, store manager, at this season of the year many people jump at the chance to enter a store and "warm up." Therefore, he issued this invitation and placed a few chairs close to his parts counter for accommodation.

Approximately fifteen people a day take advantage of this offer, and although on entering they may not intend to buy anything, some discussion on radio generally starts and few leave the shop without purchasing some article.

"Voltmeters seem to be the weak point," says Mr. Schonbrun. "I find that few set owners have one of these instruments and always suggest them. A local newspaper radio section is kept handy, as by merely mentioning a new circuit or 'stunt' in it a conversation can be easily started. Conversation breeds familiarity and usually results in sales.

This idea may be used to advantage by dealers in outlying towns whose stores are located near bus terminals, trolley stations, or other transportation centers. For there is nothing more profitable to the retail merchant than a large personal acquaintance.

Sorting the Antenna Wire Stock

Rolls of antenna wire detract from the appearance of the store and slow down sales when thrown indiscriminately into boxes or placed in confusion under the store counter. Small pegs driven into the floor or fastened on the wall behind the sales counter in "ring-toss" fashion do much to keep the wire stock in order. Assigning one "peg" to each type and length roll eliminates confusion and presents a good appearance.

"Radio Retailing" Now in Its Third Year

"To bring before the radio dealers of America the best merchandising thought and practical experience—to disseminate sound business practices throughout the industry—and to lead a prospering retail trade in supplying the needs of millions for the world's most marvelous merchandise—the publishers dedicate these pages."

In the above words, in January two years ago, the plans and purposes of *Radio Retailing* were set forth. The months since have been hectic and busy for the radio trade and for ourselves. But as we glance back through the pages of 1925 and 1926, with all their problems of stock shortages, dumping, the gyp, changing models, ether confusion, etc., we realize how much dangers have been faced and triumphantly passed, and how much has been accomplished toward stabilization of the radio industry.

But there is still much to do, and *Radio Retailing* sees its own part in bringing about further progress, as follows:

Costs and profits of radio selling must be determined and analyzed. A simple, uniform bookkeeping system for radio retailers is needed.

A uniform date for announcement of lines must be promoted. Trade-in practices must be standardized. Servicing must be developed as a means to customer satisfaction and to more sales.

The retail trade must be aided toward a greater dissemination of radio to the public, and thus to greater expansion and profits.

The great farm market has yet to be realized upon. Parts sales must be developed. And local interference must be minimized.

To these purposes and to helping the radio trade realize its fullest development and usefulness, the editors and publishers rededicate their efforts for 1927.

* * *

The Question of Sidelines and Off-Season Sales

THE question whether or not radio retailers should sell a sideline during the summer is again in the spotlight. Theoretically it should not be necessary. Actually, it is apparently the only way—or one of the few ways—by which radio dealers can keep their heads above water from May to September.

Theoretically, the radio industry should embark upon a vigorous campaign to keep retail sales going twelve months a year. Manufacturers, for one, should not set a bad example by adopting a policy of retrenchment and timidity when sales begin to drop off. In fact, when the sales curve starts downward that is the time when sales pressure is most needed.

Off-season advertising and sales effort should not be noticeable by its absence. Consistent application toward the goal of retail radio sales throughout the twelve months should be the united effort of the industry. In the course of time such a procedure could not do otherwise than achieve beneficial results.

Meanwhile, in the absence of such united industry action, it will probably be wise for retailers to invest—in a small way at first—in some sort of a sideline that has its sales peak during the warm weather. What that sideline shall be, each individual dealer must decide for himself, after due study of his local conditions.

* * *

What Does the Farmer Do— Winter Evenings?

ENTERTAINMENT—without the long trip to town over sleety roads, without the discomfort of a blanket-wrapped, ear-muffled expedition into a freezing world and a stiff, sharp wind, is what radio offers the northern farmer this winter.

Towns are a long way from the farm home when the going is rough. The pleasure of an evening at the "movies" is often offset by the discomforts of the trip. Radio offers better entertainment than the farmer can possibly buy, and cheaper—in the glow of his own fireplace. Orchestral concerts from New York, Chicago, Los Angeles, singers from Davenport, Hastings and hundreds of other cities merely at the twist of a dial.

Ask your farm prospect what he does of a winter evening. Sell him a radio set and *entertainment* now, with the assurance that when winter is over and the family can get to town comfortably next spring, the set will be worth its weight in gold as an oracle of market quotations, produce reports and weather forecasts.

* * *

Encourage Your Dealer Friends to Attend the Trade Show

SEVERAL leading manufacturers have signified their intention to hold their 1927 sales convention for dealers and jobbers at Chicago next June at about the time of the RMA trade show at the Stevens Hotel the week of June 13, thus giving their distributors an opportunity to kill two birds with one stone.

It seems to be a logical move and one that should be given serious consideration by every manufacturer. The more men of the trade there are in Chicago at trade show time, the more successful the industry's first trade show is going to be. Dealers, distributors and manufacturers should make every effort to be in Chicago next June and attend the show.

* * *

One Way to Increase Exports

THERE is one very definite way to increase American radio exports, according to officials of the Export Division of the Department of Commerce, and that is, to make American programs available for rebroadcasting in foreign countries.

In most countries, broadcasting is scarce, and what there is, is low in quality. If technical problems can be overcome, and a suitable arrangement made whereby programs broadcast in this country can be picked up and rebroadcast by foreign stations, American radio exports will benefit. Recent developments in the short wave field offer the hope that this can be done successfully if stations here and "over there" will co-operate.

This to Say—

**Radio
Retailing**

Vol. 5, No. 2

The Public Shows Itself Willing To Pay for Programs

A SIGNIFICANT development in the annals of broadcasting is reported from the Pacific Coast where 7,000 San Franciscans subscribed \$25,000 to make possible the broadcasting of the weekly programs of the San Francisco Symphony Orchestra. The orchestra, which ranks among the foremost in the country, settled upon this figure as the necessary recompense for the anticipated loss of attendance due to the broadcasting of programs. Instead of attempting to raise the money within the ranks of the trade, the radio men undertook a campaign of publicity under the direction of the Pacific Coast Radio Trade Association and succeeded in interesting the public sufficiently to meet the obligation. The result is a greater appreciation on the part of the public of what they are getting over the air—and the foundation laid for a civic pride in local broadcasting which may lead to further developments in the future.

* * *

Helping the Interference Situation by Self-effacement

UNTIL a few months ago, the Youngstown Radio Shop, Youngstown, Ohio, owned and operated its own broadcasting station. "But we decided to shut down in favor of Cleveland," states R. G. Phillips, the majority owner of this station. "We became convinced that we should step out in favor of the better programs which the larger city was able to present. In a city of only 50,000 population, it is practically impossible to compete in variety and quality with the metropolitan centers. From the cold dollars and cents viewpoint, I am convinced that it costs the Youngstown Radio Shop less money to pay for time on the Cleveland wavelength and I know we get better distribution of our advertising message."

Here is an instance of an alleviation of the present interference situation coming from within the industry. Mr. Phillips' reasoning is sound. It is to be hoped that many more of the smaller stations with limited facilities will also see the light in the near future and help solve, by the process of self-effacement, the perplexing situation that will face the radio administering body when it shall be appointed.

* * *

Ethics in Advertising

UNITS supplying A-battery power from the light socket cannot be termed "battery eliminators" if they contain storage cells of any kind.

Unless all storage cells are eliminated altogether from the A-power unit, it is wholly misleading to advertise the unit as "batteryless" or "eliminates the storage battery." It may eliminate the nuisance, and fuss entailed in caring for a large, separate storage battery, but it does not eliminate the storage battery unless it contains no storage cells, and should not be advertised as an A-battery eliminator. This applies to manufacturers as well as dealers.

Radio Retailing, February, 1927

Radio Retailing was the first radio magazine to cooperate with the National Better Business Bureau in attempting to set up a code of ethics in radio advertising and it is in conformity with the policy both of the Bureau and of this magazine, that A-battery power units be advertised as outlined in the paragraphs above.

* * *

Statistics—and the Function of a Trade Paper

ASSUREDLY it is not the function of a trade paper to prepare statistics concerning the industry it represents. It is the function of a trade paper to disseminate statistics as they are prepared by the industry itself.

In the absence, however, of any success on the part of the industry in collecting its own figures, it becomes the duty of a trade paper to make some sort of an attempt at the job. That job, in the past, this publication has tried to do.

Such statistics as we have prepared have been at best only estimates. Pretty accurate estimates, it's true, but estimates, nevertheless, due to a disinclination on the part of manufacturers to trust anybody with their individual production figures—even officers of their own associations—as these officials themselves have told us. They probably believe it is nobody's business and they may be right, but without accurate individual figures, there can be no accurate total figures, and no one can deny the advisability of knowing accurately the gross figures on yearly sales and production.

The plan of the Radio Manufacturers' Association to have production figures collected through the Harvard School of Business sheds a ray of hope on the subject. With this move *Radio Retailing* is heartily in accord.

* * *

Wild Rumors—Investigate Before You Believe Them

ONCE again wild rumors concerning the financial stability of many radio manufacturers are being circulated in the trade. Most of these rumors are unfounded in fact and circulated maliciously.

When you hear—or read—a rumor concerning a manufacturer in which you are vitally interested, don't jump at conclusions. Verify it—or prove it unfounded—before you pass judgment. Give your manufacturers an even break—don't believe the worst until the worst is proved. There are many ways of ascertaining whether the rumor is false or true.

Radio Retailing offers its assistance in answering inquiries of this nature.

* * *

1,000 Defenders of the Faith

OVER 1,000 readers of *Radio Retailing* signed and returned the "Letter to Congress" printed in the November issue. Which proves many things, foremost among which is that a great industry like ours will rise in defense of its rights when the facts are presented to it.



What's New in Radio and

This editorial section is prepared purely as a news service, to keep readers of "Radio Retailing" informed of new products.

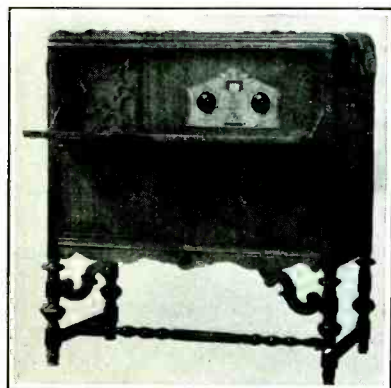

Seven-Tube Single Dial Neutrodyne

Radio Retailing, February, 1927

Illustrated is the seven-tube, completely shielded single-dial control Neutrodyne being made by the King-Hinners Radio Company, Inc., Buffalo, New York. This console model, known as No. 72-H has an enclosed loop, uses standard tubes and is equipped with UX type sockets. It has an over-all height of 40 in., a depth of 22 in. and width of 36 in. Straight-line wavelength condensers are used to tune the 4 stages of radio frequency. Transformer coupled audio frequency amplification is used and provision is made for the use of power tubes. According to the manufacturer the completeness of the shielding prevents any direct coil pick-up. The cabinet is of blended two-tone design. The intended retail price with built-in loop, \$375. No. 71-H, which is similar, but not furnished for loop operation, has an intended retail price of \$325.



Cone Reproducer

Radio Retailing, February, 1927

The Wirt Company, 5221 Greene St., Germantown, Philadelphia, is making a cone reproducer under its own name. This is made in a drum form and is easily adjustable by means of a knob located at the back of the reproducer. The free-edge cone used is designed for operation with the new power tubes. The finish is a soft neutral bronze, and the grill work is backed with silk. Intended retail price \$20.

Eight-Tube, Loop Operated Receiver

Radio Retailing, February, 1927

Illustrated is model 850, an eight-tube, single control, loop operated neutrodyne set, being made by Freed-Eisemann Radio Corp., Junius & Liberty Sts., Brooklyn. This walnut highboy console is of Italian Renaissance design. The upper left hand door conceals a cone speaker covered with carved grill work. The right hand door closes the compartment in which the loop is located. Set is completely self-contained and another compartment is provided for A and B battery supply. The drum control is illuminated, and each stage is individually shielded by a copper compartment. Intended retail price \$650. This same receiver in a table model has an intended retail price of \$385.

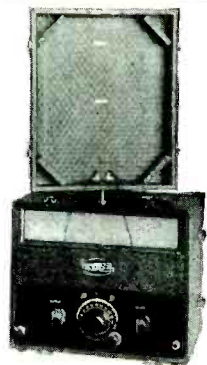

Portable Five-Tube Receiver

Radio Retailing, February, 1927

The Traveler Manufacturing Corp., 3337 N. Halsted St., Chicago, is making the illustrated portable receiver. This is a single dial control, 5-tube receiver, incorporating two stages of radio frequency, detector, and two stages of audio frequency. It operates on a loop and uses 199-type tubes. The loud speaker is built in and the total weight completely equipped is 24 lb. The case is black leatherette. The intended retail price without accessories is \$65; completely equipped, \$84.25.

Reproducer Comparator and Distortion Indicator

Radio Retailing, February, 1927

The Trimm Radio Mfg. Co., 24 So. Clinton St., Chicago, is manufacturing the illustrated device, by means of which a quick comparison may be made of any one of four reproducers. It also has a 0-15 milliammeter in series with the switch. By means of this device, not only can a quick comparison of the values of various loud speakers be made but indication of proper biasing is also at once evident on the meter. If there is any distortion present this is readily seen. This device should prove a great aid for both salesmen and service men.

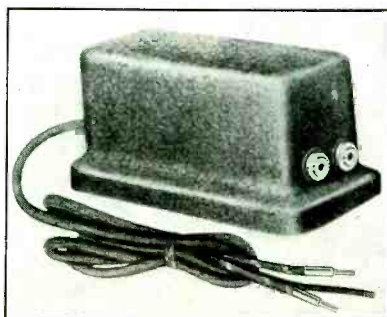
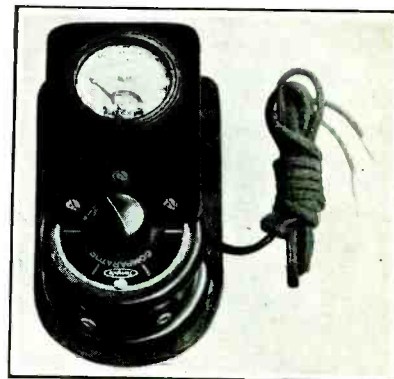

Filter for Loud Speaker Circuit

Radio Retailing, February, 1927

A device called the "Orthophone" is being made by Amsco Products, Inc., Broome & Lafayette Streets, New York City, for use in a loud speaker circuit. This consists of reactances, designed to eliminate the direct current from the loudspeaker winding and is made so that it may be attached externally between the output of the receiving set and the loudspeaker. If desired it may be mounted within the receiving set itself. Use of this device, according to the manufacturer, will give improved reproduction and relieve the strain which might have been placed on the loudspeaker. The intended retail price is \$6.

Where to Buy It

For Additional Information
on New Parts See Page 93

All announcements appearing on these pages are published without advertising considerations of any kind whatsoever.



Six-Tube Single Control Receiver

Radio Retailing, February, 1927

The illustrated model No. 6-G, is the latest addition to the Kolster line of receiving sets made by the Federal-Brandes, Incorporated, Woolworth Building, New York City. One of the unique features of the set is that the two doors, which cover the panel when the set is not in use, can be swung back until they rest against the sides of the cabinet, out of sight instead of projecting forward at an angle. A single control tunes the station selector. An elliptical cone speaker is built into the cabinet below the panel. A lower compartment in the console is used for batteries or eliminators. Either an outdoor or indoor antenna may be used. Intended retail price, \$185.

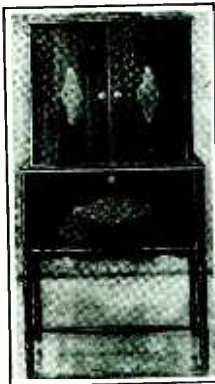

Five-Tube, Two Dial Control Receiver

Radio Retailing, February, 1927

The Valley Electric Co., 4515 Shaw Ave., St. Louis, has introduced a new two dial control receiver, known as Model 52. Its dials are mounted in the rear of the panel and windows are provided for reading the scale. A small switch is provided at one corner of the set, the operation of which gives long or short antenna effect. The antenna circuit is tuned separately. A volume control is provided as well as a filament switch. The circuit uses a potential balance method and is so designed that a power tube may be used in the last stage, the change being accomplished by means of a simple switching arrangement in the interior of the set.

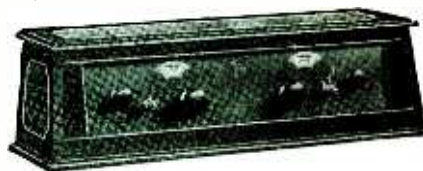

Single Tube With Three Sets of Elements

Radio Retailing, February, 1927

The Emerson Radval Corporation, 25 West 43rd Street, New York City, is making the illustrated multivalve tube. This contains three separate grids and plates with a single five-volt filament divided into three sections connected in series so as to operate from a six-volt storage battery. The tube is equipped with a standard base and may be placed in an ordinary socket operating as a single tube if desired. The two extra plate and grid connections are brought out at the top of the bakelite socket as shown in the illustration. The characteristics of each of the three units contained in the multivalve lie between the 199 and 201A tubes. The plates will take any voltage up to 135. The intended retail price is \$6.50.



B Battery Eliminator

Radio Retailing, February, 1927

The Northland Radio Company, 301 N. Seventh St., Minneapolis, Minn., makes the illustrated B battery eliminator No. 1, designed to operate on 105-120 volt, 50 or 60 cycle current. This is said to deliver ample constant current at 100 volts to operate a set using up to ten tubes. The intended retail price is \$24.50.

B Battery eliminator No. 2 is designed to deliver up to 135 volts, has an intermediate voltage of 90 and a variable detector voltage of 15 to 90 volts. The intended retail price of this model is \$29.50.

B Battery eliminator No. 3 is designed for use on direct current and is incased, as are the other two models, in 22-gage pressed steel. It is said that this model will also deliver constantly without variation, ample current to operate any multi-tube set. The intended retail price is \$21.

Modified Cone Reproducer

Radio Retailing, February, 1927

The illustrated Model S-3 reproducer is made by Claravox, Inc., Canton, Ohio. The cone or diaphragm, which has been treated to protect it from atmospheric conditions, rests on the convex of the standard where it is thoroughly protected by a scross grill. The speaker is also equipped with a special filter system placed in the base of the standard. Two models are being made at present, the S-3 and R-3. Model R-3 has a silk covered grill with a gilt molding set into the opening of the bell. Model S-3 has a polished walnut rim 1 1/2-in. in diam. by 1 1/8-in. wide with a black inner and outer edge which, together with a gold inner rim, give it a very attractive appearance. The intended retail price of Model S-3 is \$48, that of Model R-3, \$42.50.

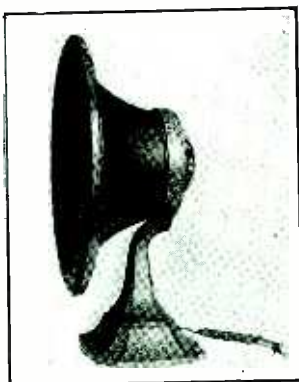

Short Wave Converting Unit

Radio Retailing, February, 1927

The Crosley Radio Corporation, Cincinnati, is now in production on the illustrated device known as "Lowave." This is intended to be connected to the antenna post of any radio receiving set and by means of a switch will allow the set to be operated on shorter wave lengths. It does not interfere in any way with reception of ordinary broadcasting wave lengths according to the manufacturer. It resembles an ordinary radio receiving set as can be seen, except that it is but one-third the size of the average five-tube set. It will operate with any type of set—even a crystal receiving set. However, it is intended primarily for use with the usual type of radio receiver having four or more tubes.

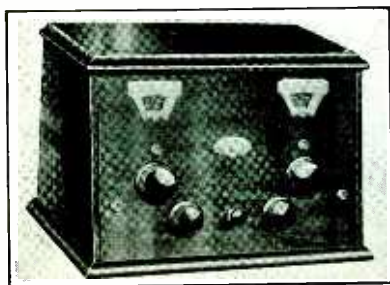

Wave-Traps

Radio Retailing, February, 1927

The Day-Fan Electric Company, Dayton, O., is making the illustrated wave-trap known as the "Fantenna." This is adaptable to practically any radio receiving set using tubes and is said to greatly increase volume and range. It is simple to install, requiring only the connection of three wires and does not use any tubes. Intended retail price \$25.



What's New in Radio and Where to Buy It—



Power Unit Test Panel

Radio Retailing, February, 1927

The Gould Storage Battery Co., Inc., 250 Park Avenue, New York City, is making the illustrated Power Unit Test Panel, designed for use by service men. Although it is primarily designed for the Gould Unipower line of eliminators it may be readily used to test A and B power supply units of other manufacturers. The panel is of Bakelite, and all necessary meters for routine test as well as tests of separate elements of power units are mounted on it. Where direct current only is available, a small rotary converter, also supplied, enables the proper servicing of alternating current equipment. Intended retail price of the rotary converter is \$39.35. The panel is portable and is accompanied by full instructions. Intended retail price \$64.50.

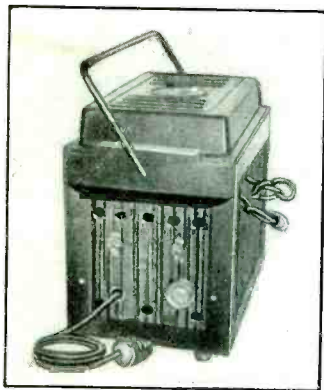

Power Unit for A-Battery Supply

Radio Retailing, February, 1927

The Victor Storage Battery Co., Rock Island, Ill., is making an A power unit which includes a 2-amp. rectifying tube in combination with a 16 amp.-hr. storage battery. It is designed for use on a 110-volt 60-cycle current. The charging unit also can be operated on a trickle rate of $\frac{1}{2}$ amp. The over-all dimensions of the unit are 10 $\frac{1}{4}$ in. long 7 in. wide and 9 $\frac{1}{2}$ in. high.

Window Lead-In

Radio Retailing, February, 1927

The B & B Engineering Co., Chicago, is making lead-in insulators of copper ribbon with a heavy woven fabric covering. This is impregnated in a water-proofing compound. The ends are equipped with Fahnestock clips securely riveted. These lead-ins come in 16 in. and 12 in. lengths with intended retail prices of 35 and 30c. each respectively, if enameled, and if plain copper 25 and 20c. each.

B Power Unit

Radio Retailing, February, 1927

A B power unit has been introduced by the Valley Electric Co., 4515 Shaw Avenue, St. Louis, which uses a Raytheon tube. According to its manufacturers, the unit is capable of supplying plate current to sets capable of using from one to twelve tubes. Two sets of connections are provided to the primary of the transformer permitting a change from a high voltage tap to a low tap. A toggle switch is mounted on the eliminator so that the plug to the house current may be left connected at all times.



Copper Shielded Tube

Radio Retailing, February, 1927

The Strongson self-shielded copper plated radio tube made by the Moulded Products Corp., 549 W. 52nd St., New York City, isolates microphonic noises originating within it and prevents electrical and magnetic interaction between tube stages, by drawing off this interference through a ground to the negative A terminal. This is said to aid tuning and to give better tone. Intended retail price, \$3.50.

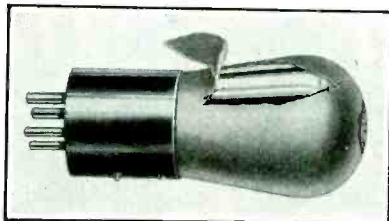

Charge-Indicating Hydrometer Ball

Radio Retailing, February, 1927

The Chaslyn Company, 4611 Ravenswood Ave., Chicago, makes the SOS Hydrometer and the Chaslyn balls used in it. These balls are arranged in three colors, white, green and red. When all three float in a solution the unit is fully charged; if the white one sinks the charge is dropping slightly; if the green one sinks the charge is very low; and when the red one sinks the unit is dead. These balls may be used not only in hydrometers but in electrolytic types of power units and B-storage batteries. They are made of strong composition and not affected by acid. The retail price of the hydrometer complete is 75c.



A and B Battery Charger

Radio Retailing, February, 1927

The King Electric Manufacturing Company, 1681 Fillmore Ave., Buffalo, N. Y., is making the illustrated "Electron Junior" battery charger. It uses a standard 2 $\frac{1}{2}$ amp. tube and has a three winding transformer. The case is dark blue. Intended retail prices, complete with tube, are as follows: For use with 25 cycle current, \$25; 40 cycle, \$22; 50 cycle, \$20; and 60 cycle, \$18.50.

Interference Eliminator Filter Condenser Unit

Radio Retailing, February, 1927

Radio interference filter No. 1, as illustrated, is being marketed by the Tobe-Deutschmann Company, Cornhill, Boston. This is designed for eliminating interference caused by household appliances using motors up to and including $\frac{1}{4}$ -hp. It is made small enough so that it can be incorporated as part of the device. In all cases, this filter should be placed as close to the offending motor as possible. The leads to the



brushes should be cut as close as possible to the motor and the filter placed so that at the end where there are three leads, the center lead is connected to the frame of the motor.

News of Latest Products Gathered by the Editors



Output Transformer

Radio Retailing, February, 1927

No. 27-B "Output Superaudioformer," manufactured by the Pacent Electric Company, Inc., 91 Seventh Avenue, New York City, is designed for use in loud speaker filter circuits. Placed between the plate of the last audio tube and the speaker it isolates high voltage from the speaker windings. The primary winding of the transformer, through which the direct current plate voltage is carried to the plate of the last audio tube, is designed to carry up to 40 milliamp. The unit will operate at voltages up to 500. Intended retail price, \$7.50; unshielded, \$6.

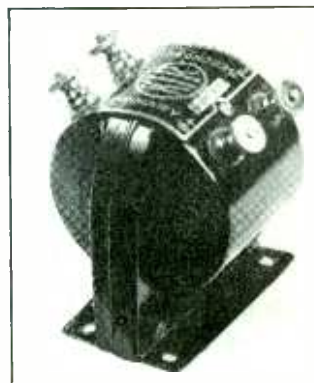

Shielded Audio Transformer

Radio Retailing, February, 1927

The "KIR" audio transformer, illustrated, is manufactured by S. J. Wise & Company, 40 Place Verte, Antwerp, Belgium. It is totally shielded in a black enameled case and is equipped with nickel-plated connection terminals. According to the manufacturer, the transformer provides excellent amplification especially at low frequencies. The turn ratio is approximately 3 to 1.

Tuned Radio Frequency Coils

Radio Retailing, February, 1927

The Robertson-Davis Company, Inc., 412 Orleans Street, Chicago, manufactures a line of radio frequency transformers mounted in Bakelite cases, known as "Melocouplers." Model 120, illustrated, has a bank wound secondary of low d.c. resistance and is used in circuits where a low primary impedance is desired. Model 160, mounted in a similar case, is a duplicate but with a higher primary impedance. Melocoupler 135 is an intermediate transformer for long wave reception, designed for use at wavelengths above 2,400 meters when shunted by the proper variable condenser. The natural resonant frequency in this later model is about 124 kilocycles. Melocoupler 120 and 160 may



be used in super-heterodyne construction as mixing transformer and oscillation transformer respectively. Both these instruments are especially recommended in the construction of the "Melocoupler" circuit. Height, 2 1/2 in. Intended retail price, Model 120, \$5.75; model 135, \$6 and model 160, \$5.25.

Fixed Condenser in Cartridge Container

Radio Retailing, February, 1927

"Bee-Cee" by-pass and filter condensers, manufactured by Brown & Caine, Inc., 2317 Calumet Avenue, Chicago, in capacities from .1 mfd. to 2 mfd. are incased in cartridge-like containers with nickeled metal ends. The condensers are impregnated in "Halowax," a moisture excluding compound. These condensers may be obtained in two types, with a rated voltage of 180 d.c. or designed to operate continuously on voltages up to 360. Intended retail prices range from 75c. to \$2.50.



Coupling Unit for Truphonic Audio Amplification

Radio Retailing, February, 1927

No. 301 individual "Truphonic" coupler, made by the Alden Manufacturing Company, Springfield, Mass., is incased in a metal container similar to that of a large audio transformer and may be used to construct an amplifier similar to the complete, "truphonic" unit manufactured by this company. This system is said to provide nearly perfect audio amplification over the entire broadcast frequency range and to operate efficiently when used with any of the various type tubes on the market. A patented feature in the coupler used as a first stage step-up



unit is a device designed to prevent "motor-boating," which commonly occurs in impedance and resistance amplifiers when used with B battery eliminators, according to the company. The unit is intended to retail for \$5.

Variable Balancing Condenser With 14 to 1 Vernier

Radio Retailing, February, 1927

The Canotex Company, Auburn, N. Y., manufactures the illustrated balancing condenser in two sizes. No. 1 has a minimum capacity of 13 mmfd. and a maximum of 20 mmfd. No. 2 has a minimum capacity of 4 mmfd. and a maximum of 70 mmfd. Both units are easily mounted, and are provided with 14 to 1 verniers and a lock screw adjustment which permits constant capacity to be maintained. Intended retail price, \$1.

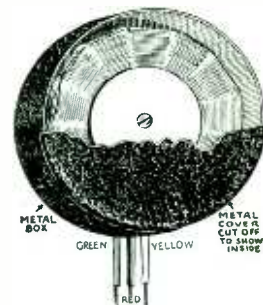

Shielded R. F. Coil

Radio Retailing, February, 1927

Sharp tuning and low distributed capacity is claimed for the illustrated coil manufactured by the Feri Radio Manufacturing Company, 1167 Bedford Avenue, Brooklyn, N. Y. The coil is wound pancake form and is totally shielded in a lacquered metal case. Terminals are brought out through the case and are well insulated. Made in sets for use with tuning condensers of standard capacities. Intended retail price, sets of three, \$6.

Complete Five-Tube Shielded Receiver Kit

Radio Retailing, February, 1927

The Grimes "I. D. S." kit, manufactured by the Grimes Radio Engineering Company, Inc., Long Island City, N. Y. contains complete equipment for the assembly of a five-tube, shielded receiver employing the "Inverse Duplex" system of reflexing, including a knock-down, crackle-finished aluminum cabinet. The set is designed for three control operation. The panel is drilled and engraved. Parts of well-known manufacturers are made up in the kit. Sampson supplies the loudspeaker output impedance, DeJur the resistance audio amplifier, Benjamin the tube sockets, Lind the tuning condensers, Electrad the volume control resistance, Sangamo the fixed condensers, Dubilier the output blocking condenser and Acme the connection wire. The intended retail price of the assembly is \$57.50.

What's New in Radio and Where to Buy It—

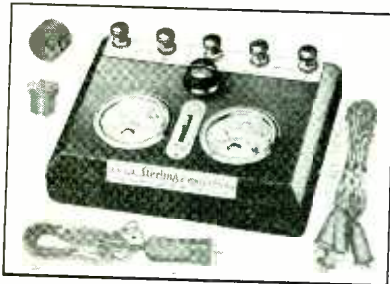

Testing Instrument for B Eliminator

Radio Retailing, February, 1927

The Sterling Mfg. Co., 2831 Prospect Ave., Cleveland, O., is making Type R-4 110 "Universal Sterling B Power Tester," designed for use with B battery eliminators. It is equipped with a coupling switch whereby the voltmeter and milliammeter can be operated together, or by turning the rheostat knob the milliamp. load may be varied at will and its corresponding voltage output read simultaneously on the voltmeter. When the switch is placed in the opposite position the 0-300 scale voltmeter and the 0-100 scale milliammeter function independently. Over-all dimensions are 7 in. long, 5½ in. wide and 2½ in. high. The finish is dark green frostine with nickel trimmings. The complete equipment consists of 4 black and red insulated connecting leads, 2 socket plug and leads with 2 adapters for all sockets, also hook-up diagram. This tester can also be used to check the output of any d.c. generator such as is used in transmitting sets. Intended retail price, \$40.



Power Unit for Filament Supply

Radio Retailing, February, 1927

The Acme Electric and Manufacturing Company, 1444 Hamilton Avenue, Cleveland, is making a power unit for filament supply. The storage battery is of 50 amp-hr. capacity and the trickle charger incorporated has two rates, one of ½ amp. and the other of 1½ amp. A small switch controls the rates. The unit is mounted in a rubber case that has four compartments. Three of these compartments hold the 6-volt storage battery elements, and the fourth compartment contains the trickle charger. The intended retail price is \$35.00. The price of bulb is \$4.00 extra. This unit is designed to operate on 110-volt, 60 cycle current.

Correction of Address

In the January issue of *Radio Retailing*, on page 67, the Delta Electric Company of Marion, Indiana, was erroneously listed as Marion, Ohio. This company manufactures the Delta battery chargers.

Filter Unit for A Battery Elimination

Radio Retailing, February, 1927

The "Abox Filter" is made by the Abox Company, 215 N. Michigan Ave., Chicago. This consists of two condensers, and a choke coil arranged in the conventional filter circuit. The condensers are a new electrolytic type of large capacity and, according to the manufacturer, will smooth out low voltage currents up to 5 amp. For A battery elimination with this filter unit, the charging device, with the exception of vibrating type of charges which are not recommended, is connected directly to the filter which in turn is connected to the radio set. The unit is shipped dry in a paper carton and upon receipt it is necessary to add distilled water before attempting operation. Intended retail price, \$19.50.



Antenna Kit

Radio Retailing, February, 1927

The Cornish Wire Company, 30 Church St., New York City, is now making a complete line of antenna kits. These kits cover the entire price range from a list of \$4.50 for the No. 1 deluxe kit, containing the highest grade products, down to a cheap kit listing at \$1.75. The No. 1 kit lists at \$4.50; No. 2 at \$3.50; No. 3 at \$3; No. 4 at \$2.50; No. 5 at \$2; and No. 6 at \$1.75. Kits Nos. 1, 2 and 3 contain the Brach Storm King Lightning Arrester. Each kit contains all of the necessary equipment to install a good antenna. These kits make it much easier for the dealer to handle antenna equipment.

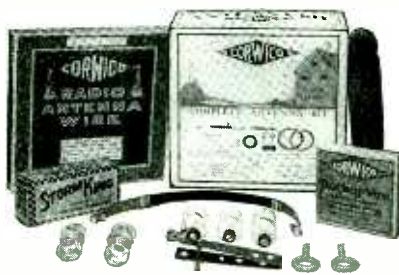

Portable Light for Radio Set

Radio Retailing, February, 1927

Vimco Manufacturing Company, Inc., 721 Ellicott Square, Buffalo, N. Y., is making the illustrated light designed to be used with the radio set to illuminate the panel face. It is to be used on the house current. The base is of white metal sufficiently weighted to prevent tipping and the finish is a soft bronze. A two-piece socket and movable shade permit separate adjustment of the lamp. It is 2½ in. high by 7½ in. from front to back. The intended retail price is \$3.85.



Combined Lead-In Insulator and Lightning Arrester

Radio Retailing, February, 1927

R. Wright, Walkerton, Ind., makes the illustrated combination switch and lead-in insulator. When in use the terminal arrangement on the outside acts as a lightning arrester and by means of a rod running through the insulated lead-in tube, the antenna may be grounded. This rod operates as a push-pull switch from the inside of the house.

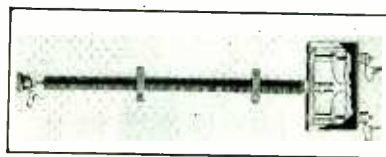

Device for Converting Direct Current Into 60-Cycle A.C.

Radio Retailing, February, 1927

Radio receivers and equipment, designed for operation on alternating current, require a converting device where direct current only is available. In the Dynamotor R-144, one of the devices offered by the Electric Specialty Company, Stamford, Conn. a.c. radio receivers, loud speakers and phonographs may be converted for d.c. use without causing any hum in the receiver or loudspeaker, the company declares. The results obtained with the dynamotor are similar to those obtained from any 60-cycle lighting socket and with the motor-generator, also made by the company, results are even better, it is claimed. Both dynamotors and motor-generators are equipped with specially designed filters, mounted on top. The device can be easily installed by any electrician and can be operated on 10 or 15-amp. fuses.



What the Trade is Talking About

Resolutions Favor White Bill

Two resolutions recently passed by radio organizations are indirect endorsements of the radio bill as drawn by Representative Wallace H. White.

The Radio Jobbers' Section of the New York Electrical Board of Trade, and the Broadcast Listeners' Association of Indianapolis are the organizations which have urged radio legislation along the lines of the White Bill. In the case of the resolution of the Broadcast Listeners' Association, direct endorsement of the Department of Commerce as the radio authority is made.

Spokane Radio Trade Association Formed

Under the direction of George H. Thompson, of Portland, Ore., the Spokane Radio Trades Association, Spokane, Wash., has been formed. C. W. Bell, head of Sherman Clay's radio department, has been elected president, L. F. Olney, of Stewart-Warner Products Company, vice-president, and C. E. Frazier of the Interstate Radio Company, secretary-treasurer. The board of trustees is composed of N. P. Rich, T. Farbro, William E. Chase and A. M. Oldershaw.

Crosley to Manage De Forest Radio for Five Years

Powel Crosley, Jr., president of the Crosley Radio Corporation, Cincinnati, is to take over the management of the De Forest Radio Company of Jersey City for a period of five years, according to Arthur F. Lord, receiver for the latter company, which went into bankruptcy last June.

Crosley's offer to advance \$300,000 for the continuance of the De Forest Company's business, with the understanding that he is to manage the concern and be authorized to appoint members of the board of trustees during this period, has been accepted by the company's stockholders and creditors.

Under this arrangement Mr. Crosley is to receive three per cent commission on the De Forest Company's first \$3,000,000 of annual net sales and 1½ per cent on annual sales over this amount. He is also to receive 39,000 shares of the concern's outstanding treasury stock of 211,000 shares, this stock to be placed in escrow in a Cincinnati bank until it earns \$150 in any fiscal year, when it is to become his property.

Journal of Electricity Changes Name to Electrical West

On Jan. 1, 1927, the *Journal of Electricity* of San Francisco changed its name to *Electrical West*. Serving as it does the electrical industry of the eleven Western States, the new name will more closely define the field and the function of the paper. Beginning with the January, 1927, issue, *Electrical West* will be published monthly, on the first of the month, instead of semi-monthly as in the past.

The *Journal of Electricity* was founded in 1887 and has now served the special needs of the electrical industry of the West for almost forty years. It has been the medium for the development and the interchange of ideas and plans through every period of the outstanding engineering and commercial achievements of that section. Under its new name, *Electrical West*, the publisher announces,

this tradition of service will be faithfully upheld and editorial plans call for even more particularized attention to the special needs of this great electrical empire of the West.

E. E. Shumaker Heads Victor

Edward E. Shumaker, who two years ago was elected a vice-president of the Victor Talking Machine Company, has been elevated to the presidency, succeeding Eldridge R. Johnson, who resigned following the recent sale of his stock holdings. Belford G. Royal, a member of the board, has been elected chairman; Fenimore Johnson, son of the former president, becomes a vice-president; Walter J. Staats, formerly treasurer, moves up as vice-president in charge of foreign business, and Elmer Grimler becomes treasurer from the position of comptroller. The following additions have been made to the board of directors: DeWitt Millhauser representing Speyer & Company, and John C. Jay, of J. & W. Seligman & Company, recent purchasers of a controlling interest in the company.

Federated Trade Associations To Meet in St. Louis

The Federated Radio Trade Associations, composed of a number of state and territorial associations in the middle west, has selected the Coronado Hotel, St. Louis, as headquarters for its second annual convention and election of officers. The hotel is expected to be a scene of great activity during the days of the convention, Feb. 14-15, and a detailed program of matters of national importance to come before the association is being arranged.

I. R. E. Convention Held in New York



A banquet at the Waldorf-Astoria Hotel, New York City, on Wednesday, January 12, closed the three-day convention of the Institute of Radio Engineers held Jan. 10, 11, and 12 at the same hotel. The banquet marked the end of three days of meetings at which many papers on technical subjects were presented by well-known radio engineers. Social activ-

ities during the convention included trips to nearby radio factories and broadcasting stations. Officers elected for the coming year were: Donald McNicol, president; Dr. Ralph Brown, vice-president; Dr. J. H. Dellinger, junior past president; Dr. A. N. Goldsmith, secretary; W. F. Hurley, treasurer. Douglas Rigney headed the Convention Committee.

Television Within a Few Years?

The transmission of radio motion pictures and practical television within the next few years is the startling prediction of Dr. E. F. W. Alexanderson, consulting engineer of the General Electric Company and of the Radio Corporation of America, who has been engaged in research work for the development of some practical system of television for a number of years. In a recent address delivered before the St. Louis section of the American Institute of Electrical Engineers, Dr. Alexanderson described a process by which he had already succeeded in transmitting and recording "still" photos in less than two minutes.

The chief difficulty confronting experimenters who are working on this problem is that of attaining sufficient mechanical speed in transmitting and recording devices. In order to transmit satisfactory moving figures Dr. Alexanderson must increase the speed of his apparatus so that it is capable of transmitting 40 single likenesses per minute. He has already made considerable progress in this direction by employing seven individual transmitting and receiving units, or light sources, each taking care of a share of the job. The system of radio transmission developed by John Hays Hammond by which several radio programs may be broadcast simultaneously on one wavelength holds an important part in the development of the Alexanderson method.

The Kodak Radio Corporation, 507 East Pearl Street, Cincinnati, has discontinued the manufacture of radio receivers and loud speakers. The company is concentrating on trickle chargers and battery eliminators.

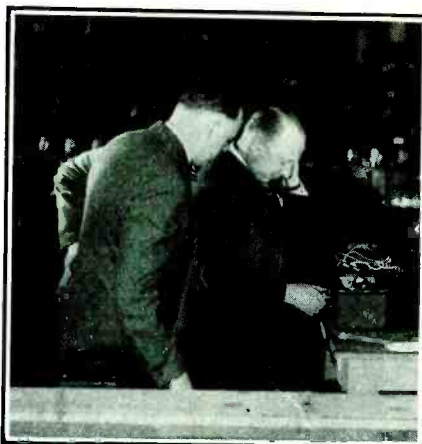

"7-14-83-16—"

This is not a photo of a famous crackman plying his trade, but no less than A. Atwater Kent twisting the single dial of his millionth radio receiver on the test block at his Philadelphia plant. On the same day 5,312 duplicates of this single-dial metal job left the factory for "points west."

Lyons and Witherbee storage batteries are now one and the same thing. Though both lines retain their original trade names and types, the Witherbee Storage Battery Company, Inc., has been absorbed by the Lyons Storage Battery Company of New York City.

Colt's Patent Fire Arms Manufacturing Company, Hartford, Conn., has absorbed the Johns-Pratt Company, manufacturer of sheet packing and electrical equipment, which it has controlled for a number of years. All activities of this latter company will henceforth be carried on under the name of the purchasing company.

Northwest Association Releases Survey of Year's Business

A survey of 1926 radio business in the Northwest territory, just released by the Northwest Radio Trade Association indicates a 10 per cent sales increase over 1925 business. Northwest dealers sold \$28,554,335 worth of radio sets, accessories and parts in 1926 as against \$25,906,250 during the previous year. Of the 1926 total, approximately half this sum was realized through the sale of sets, the balance through parts and accessories.

During the year, the number of jobbers in the Northwest territory has increased from 50 to 67. Twenty-seven are located in Minneapolis, 9 in St. Paul and 31 in the states of Minnesota, the Dakotas, Montana and Northwestern Wisconsin.

Approximately 126,950 sets were sold in the territory during the year, contrasted with 26,950 in 1925. It is estimated that there are about 400,000 sets in the St. Paul-Minneapolis territory, the population of which is 7,500,000. The twin cities and Duluth are far from sales saturation point, the association's survey indicating that but 22 per cent of the homes in these cities have radios. In the towns and smaller cities the percentage is even smaller, totalling 18 per cent and only 14 per cent of the farm homes in the section are so equipped. Less than 10 per cent of retail sales are completed on a "trade in" basis and approximately 25 per cent of all set sales are on the time-payment plan.

Omitted From Tube Listing

Due to a slip-up somewhere between the United Radio and Electric Corporation, Newark, N. J., and this office, the former company was omitted from the listings of receiving and rectifying tubes published in the November and December issues.

The United Company manufactures 11 types of "Ureco Goldentone" tubes, as follows: Dry cell tubes—X120, last audio stage, \$2.50; U199, detector and amplifier, \$2.25; X199, detector and amplifier, \$2.25. Storage battery tubes—X112, last audio stage, \$4.50; DX200, detector, \$4; X201, detector and amplifier, \$2; X210, last audio stage, \$9; X171, last audio stage, \$4.50; Hy-Mu, 1, first and second audio stages in resistance-coupled sets, \$4. Rectifier tubes—X213, full-wave, \$6; X216, half-wave, \$7.50.

May the editors take this opportunity again to impress upon manufacturers that, in order to be represented in our listings of radio products, it is necessary that they fill out and return to us promptly all blank forms or questionnaires pertaining to their product which we send out from time to time into the business three years ago.

Silver-Marshall, Inc. has appointed Mr. Bodman, former eastern sales representative, sales manager with headquarters in Chicago. F. E. Schmitt of 136 Liberty Street, New York City, replaces Mr. Bodman in the east.

Radio Shows and Conventions

February 14-15: Second Annual Convention, Federated Radio Trade Associations, Coronado Hotel, St. Louis.

February 23-24: Mid-west Radio Convention, Coliseum, Des Moines, Iowa.

June 6-11: Music Industries Chamber of Commerce Convention, Hotel Stevens, Chicago.

June 13-18: R.M.A. Convention and Trade Show, Hotel Stevens, Chicago.

August 20-27: Fourth Annual Pacific Radio Exposition, Civic Auditorium, San Francisco.

September 4-10: Fifth Annual National Radio Exposition, Ambassador Auditorium, Los Angeles, Cal.

*September 19-24: Third Annual Southwest National Radio Show, Coliseum, St. Louis.

September 19 - 24: Radio
*Tentative

World's Fair, New Madison Square Garden, New York City.

September 26-October 1: Sixth Annual Northwest Radio Show, Minneapolis Auditorium, Minneapolis.

*October 3-8: Salt Lake City Radio Show, Salt Lake City, Utah.

*October 3-8: Third Annual Indianapolis Radio Exposition, State Fair Grounds, Indianapolis.

October 3-8: Pittsburgh Radio Show, Duquesne Gardens, Pittsburgh, Pa.

October 4-9: Fifth Wisconsin Radio Exposition, Auditorium, Milwaukee, Wis.

*October 24-29: New Orleans Radio Show, New Orleans "States" Building, New Orleans.

*October 24-29: Dayton Radio Show, Dayton, Ohio.

*October 26-29: Third Annual Houston Radio Exposition, City Auditorium, Houston, Texas.

N. E. M. A. Will Sponsor Afternoon Programs for Dealers

The annual mid-winter meetings of the Radio Division of the National Electrical Manufacturers' Association were held January 19, 20 and 21 at the Waldorf-Astoria Hotel, New York City. Louis B. F. Raycroft, chairman of the Radio Division, was elected Radio Divisional Vice-President of the N. E. M. A. Two general meetings were held as well as a number of committee meetings covering many branches of the radio trade and science.

At the general meetings, talks were given by Mr. Raycroft, Alfred E. Waller, managing director of the N. E. M. A., and M. Clements, business manager of *Radio Retailing*, who presented a market analysis of the radio industry. Mr. Raycroft presided at the meetings.

An announcement of great interest to the retail trade was made during the meeting to the effect that the National Electrical Manufacturers' Association has secured an option on both the Red and Blue networks of the National Broadcasting Company and will sponsor an afternoon hour to be known as the "Nema Hour," which dealers may use for demonstration purposes. The N. E. M. A. officials believe this will fill a great need for daylight broadcasting during the hours when the store is open and good broadcasting scarce. The hour will be broadcast every weekday afternoon on a nationwide scale, so that dealers all over the country may have a dependable demonstration hour every day.

The convention came to a close on the evening of Jan. 21 with a banquet at the Waldorf-Astoria, at which talks were delivered by M. H. Aylesworth, president of the National Broadcasting Company; Douglas Rigney, of the A. H. Grebe Company, and Alfred N. Goldsmith of the Radio Corporation of America.

Freed-Eisemann Denies Rumors

The Freed-Eisemann Radio Corporation, Brooklyn, N. Y., is in as sound a financial condition at this time as it ever has been, according to an official statement by Alex Eisemann, treasurer of the corporation. The statement is issued as a denial of rumors that Freed-Eisemann was about to go into bankruptcy.

All bills have been discounted, the factory is running at satisfactory capacity for this time of year and there is a cash surplus of \$100,000, the statement declares. "Rumors of the financial instability not only of the Freed-Eisemann Company but of any company, should be accurately verified before being accepted as authentic by the trade," Mr. Eisemann said.

Mid-West Radio Convention Scheduled for February

A convention of mid-west radio dealers, jobbers, manufacturers and listeners is to be held February 23-24 in

the Coliseum, Des Moines, Iowa, under the supervision of the Radio Listener's League of Iowa. Mid-west jobbers and the Des Moines Chamber of Commerce are back of the enterprise designed to bring the varied radio interests in the central west together for a discussion of matters of mutual interest. The broadcasting situation is to be brought up in an effort to clarify the somewhat confused status of the service.

Arrangements for the convention are in the hands of a committee composed of E. O'Dea, O'Dea Hardware Company; F. St. Austell, Iowa Radio Listener's League; H. B. Lee, *Register & Tribune*; E. N. Hopkins, *Meredith Publications*; G. Hamilton, Des Moines Chamber of Commerce; G. Lathrop; H. B. Sexsmith, Harger & Blish Company; E. C. Collins, Collins Electric Company; J. McCarroll, Bankers Life Company; M. Zucker, Stewart-Warner Corporation; L. Wissler, Herring Motor Company; J. Carmichael, Iowa Public Utilities Information Bureau; F. A. Beatty, Des Moines Electric Company and C. T. Higgins, Homestead Co.

Haugh Buys Interest in Peerless Speaker

Arthur T. Haugh, president of the Radio Manufacturers' Association, recently purchased an interest in the United Radio Corporation, Rochester, N. Y., manufacturers of the Peerless Reproducer and other radio devices, and will devote much of his time to the promotion of sales for that concern. He will retain his financial interest in the various King Companies, viz. King-Buffalo, Inc., King Quality Products, Inc., and King Manufacturing Corp., of Buffalo and King Quality Products, Ltd., of Bridgeburg, Ontario, and will continue as Vice-President in Charge of Merchandising.

Selden E. May, President of the United Radio Corporation, in a statement announcing Mr. Haugh's connection, said: "We are fortunate in securing as one of our associates a man of Mr. Haugh's experience and ability. He will aid us in the marketing not only of our Peerless Reproducer but also of other radio devices which will be offered to dealers and manufacturers of receivers."

"Socket Power Unit" to Replace "Eliminator" as Radio Term

Executives of eight leading storage battery companies met on January 11, at the Waldorf-Astoria Hotel, New York City, to confer with officials of the National Better Business Bureau to discuss its work of the past year in the battery field and 1927 plans.

Those present unanimously indorsed the term, "socket power unit" as an accurate and suitable term for all devices designed to furnish A, B or C battery current for radio sets from the light socket. The term will be recommended to all manufacturers of such apparatus in order to eliminate such ambiguous expressions as "A Battery Eliminator," "B Battery Eliminator," etc.

R.C.A. Plans for '27

In a statement issued by the Radio Corporation of America to its distributors, E. E. Bucher, general sales manager, outlines its plans for 1927 to dispel rumors circulating in the trade that the entire line of Radiolas are to be radically changed during the year. The bulletin reads as follows:

"Throughout 1927, Radiola 28 and the Model 104 Loudspeaker will be continued as the leading instruments of the RCA line. The trade is urged to pay no attention to 'rumors' concerning the plans of the Radio Corporation. You will be duly and authoritatively advised of any changes in policy or sales plans. RCA never makes any move without giving the fullest consideration to trade conditions."

The Radio Master Company of Bay City, Michigan, manufacturer of plywood radio cabinets, has announced through its president, Frank Ward, the completion of a new factory unit in its program for the development of its plant and properties. The addition of this structure greatly increases the company's manufacturing facilities. Radio Master is unique among manufacturers of such equipment in that it owns its own forests, cuts its own timber and fashions it into its own cabinets.



Commercial Radio-Telephony Links Two Continents

Walter S. Gifford, president of the American Telephone and Telegraph Company, New York City, officially opened a commercial telephone service between New York and London, Eng-

land, employing radio as its linking medium, before a group of company officials on January 7. He spoke to Sir Evelyn Murray, secretary of the General Post Office of Great Britain.

News of Jobbers and Distributors

Indianapolis Distributors Form Association

Radio jobbers of the city of Indianapolis, Ind., recently met at the Hotel Severin in that city and formed the Indianapolis Radio Distributor's Association. The purposes of the organization are the acquisition and dissemination of information useful to dealers in the sale of radio sets and the establishment and promotion of a code of merchandising ethics for the general trade in the vicinity. L. D. Ginger, Hatfield Electric Company, was elected president; E. L. Kruse, Kruse-Connell Company, vice-president and F. J. Argast, Hatfield Electric Company, secretary and treasurer. The board of directors consists of Adolph Wagner, H. T. Electric Company; L. L. Banford, Stewart-Warner Service Station; C. L. Callender, Indianapolis Electric Supply Company and George A. Riser of Riser Brothers & Company.

H. H. Southgate, central sales manager for Federal-Brandes, Inc., has left New York City on a 7,000 mile trip throughout his territory, ranging from Cleveland to Denver and from Oklahoma City to Houston. He will spend several months visiting Kolster distributors. H. A. Hutchins, Jr., eastern sales manager, is making a similar tour of the east coast from Maine to Florida.

Benwood-Linze's trade catalog for the year is prefaced by a statement of its merchandising policy when dealing with Missouri retailers and an introductory letter to the trade written by Harold J. Wrape, president. The booklet contains a complete list of the products distributed by the company with list prices, photographs, available discounts and shipping data. It may be obtained by writing the company at 1830-32 Washington Avenue, St. Louis.

The C. R. Bach Company, 252 Fifth Street, San Francisco, has been appointed west coast representative for Pass & Seymour, Inc., Syracuse, N. Y., manufacturer of electrical and radio devices. A complete stock of merchandise and proper facilities for handling inquiries, orders and shipments will be maintained.

The Schneitter Radio Company, radio jobber, St. Joseph, Mo., has released its sales catalog for the year. The booklet contains 200 pages of items stocked by the company for wholesale distribution with a photograph, specifications and list price of each of items recorded. Catalogs may be obtained by writing the company at Fourth and Jule Streets.

The McGraw Company, Omaha, Neb., has added Walter Jay Lynch to its radio sales department. Mr. Lynch was formerly connected with J. Modell and Co., New York City retailer.

Chicago Jobbers Attend Trade Banquet

Most of the leading Chicago distributors of radio apparatus attended the first annual get-together banquet of the Chicago Radio Representatives Association held in that city recently. Short talks were given by members of the association and Mr. Flanagan of the Radio Manufacturers Association. The banquet committee was composed of E. F. Duskis, S. B. Darmstader, Elmer E. Mills, Royal A. Stemm and Jack Redell.

Another Jobber "Takes the Air"

Radio apparatus distributors are gradually availing themselves of the golden opportunity to advertise their merchandise via the ether and at the same time provide good programs to stimulate interest in radio. The Stewart-Warner Products Service Station, proponent of Stewart-Warner Matched-unit radio in the state of Iowa, has contracted for an hour of WHO's time every Monday evening between 8 and 9. Several well-known orchestras and singers have been obtained to put these programs across. The company is located at 1600 Locust Street, Des Moines. WHO is the business end of a 5,000 watt signal that is not confined to the state of Iowa by any means.

Gross-Brennan Celebrates Successful Year

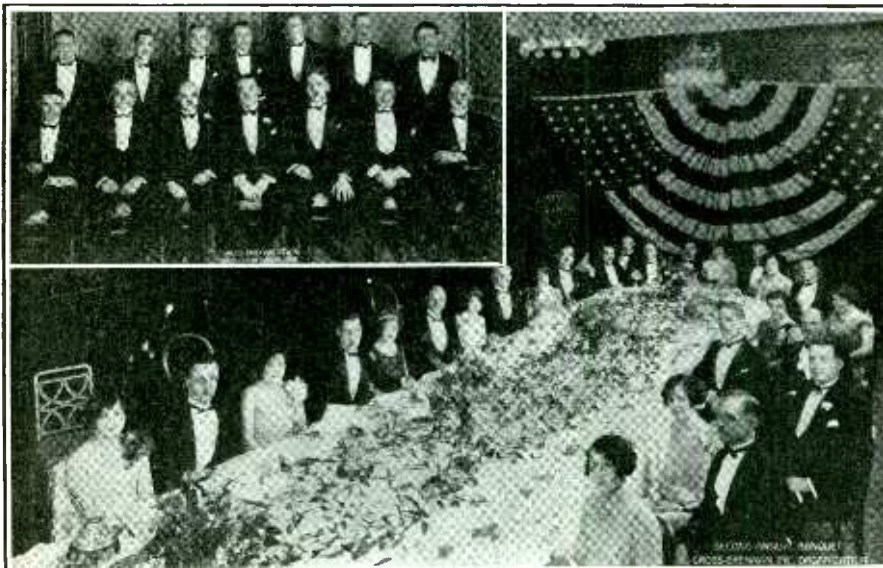

The entire sales force of Gross-Brennan, Inc., Boston and New York, sales representative for the Stromberg-Carlson Telephone Manufacturing Company, attended its second annual banquet held recently at the Waldorf-Astoria, New York City, to celebrate the most successful year in its history. Benjamin Gross and Herbert A. Brennan delivered short addresses outlining the progress of the company, expressing their appreciation for the loyalty of members of the organiza-

tion which had made its advances possible. In a lighter vein, entertainment was furnished by Mort Downey, Brunswick record artist and other popular entertainers, followed by dance music. Left to right in the insert: seated, E. K. Walter, H. C. Lansell, B. Gross, H. A. Brennan, F. G. Laughlin, W. L. Collins, A. W. Chamberlain. Standing, J. C. Springer, H. G. Bloom, W. I. Brunner, E. M. Latham, T. D. MacCoun, K. E. Bran, C. D. Jourdon.

The Southwest General Electric Supply Company, formerly the Southwest General Electric Company, Dallas, Tex., has opened a branch warehouse and sales office at Amarillo. RCA radio apparatus will be distributed from this point as well as from the company's Houston, Oklahoma City and Tulsa offices. B. G. Valkus heads the "pan-handle" branch organization as manager. T. O. Steffens is sales agent, J. G. Parkus, city salesman, P. K. Mathews, office salesman and H. A. Hitt, service manager.

The Alexander Seewald Company, 102 West Peachtree Street, Atlanta, has been appointed a distributor of Fada radio apparatus with exclusive jobbing rights for Georgia. W. D. Alexander is president and D. C. Alexander manager of the company's radio department.

Charles Rubel & Company, Inc., Washington, D. C., is the latest addition to the list of Federal "Orthosonic" jobbers. The company will distribute the entire line of radio receivers manufactured by the Federal Radio Corp.

The March-Strickle Motor Company, Spokane, Wash., of which R. L. Strickle is vice-president and manager, has entered the radio business, taking over exclusive distribution rights in the state of Washington and northern Idaho for Day-Fan receiving sets. The company is organizing a sales force for its radio department to operate as an independent unit, not connected with its automotive business in any way.

New Dealer Help Material

Aids to greater profits provided by radio manufacturers for their dealers

"Your Battery's Dead at 34"

Comparatively few set owners who use dry cell B batteries realize that such a plate battery's life of usefulness is over long before the voltage drops to zero. They seldom realize that high-frequency squeals, crackling noises and distortion are quite likely to occur when a 45 volt battery of this type is permitted to run below 34 volts or a 22½ volt block below 17 volts. The Beede Instrument Company of Penacook, N. H., supplies a small blue and white sticker which the retailer may paste to his B batteries for the purpose of stimulating sales for these accessories as well as Beede voltmeters. The dealer help paster reads as follows:

Use a "BEEDE METER" to test this battery

When a 45 volt battery tests only 34 volts and a 22½ volt battery 17 volts it is time to consider replacing them.

Weak Batteries Give Poor Reception

YOUR BATTERY DEALER WILL SUPPLY YOU WITH A BEEDE METER

The Ward Leonard Electric Company, Mount Vernon, N. Y., has just published a booklet, "How to Use Resistance in Radio," covering uses of resistance in radio circuits. Included in the booklet is a non-technical presentation of the "current supply" question.

The Farrand Manufacturing Company, Inc., Thompson Avenue, Long Island City, N. Y., is distributing a small folder to its dealers containing "special instructions for improving the operation of Farrand cone speakers." Obtaining good reproduction of music and speech requires more than a good speaker, so the company's new circular tells how to hook up B and C batteries for best results and how to install power tubes.

The All-American Radio Corporation, 4201 Belmont Avenue, Chicago, supplies a dealer help known as the "Radio Key Book," containing 50 pages of information of interest to radio set owners and prospective owners. In this booklet, which is available to All-American retailers at 5c. per copy, the fundamentals of radio are simply explained by E. N. Rauland in collaboration with Harry K. Randall, associate I.R.E. A number of popular circuits are pictured with a list of parts necessary for their construction. A log sheet and dial recording chart as well as cuts of various Rauland and All-American products are also included. The company has featured this booklet in its national advertising for some time at 10c. per copy to the consumer.

The Zetka Laboratories, 9 South Fullerton Avenue, Montclair, N. J., manufacturer of vacuum tubes, has just issued a small, two-page dealer help folder entitled, "8 Reasons Why" in which eight advantages of the Zetka tube are listed as a merchandising help. The folder is 6 x 3½ inches, with an attractive blue cover.

Tube Display Card



A broad red stripe directly behind the sample tubes mounted on this neat counter display furnished by the C. E. Manufacturing Company, Providence, R. I., throws tubes into sharp relief.

The Aluminum Company of America, Pittsburgh, Pa., has released a small pamphlet written by E. E. Free and L. M. Cockaday on "Aluminum Radio Shields." The booklet briefly explains the difference between electrostatic and electromagnetic shielding and outlines a few experiments which have been carried on to determine the correct use of aluminum as shielding in radio receivers. It also contains several tables showing the density, electrical conductivity and weight of various metals which should be of value to set builders and experimenters.

The Polymet Manufacturing Corporation, 599 Broadway, New York City, is distributing its latest catalog to the trade. The new booklet is illustrated and contains a complete price list of Polymet products. The history of the company as well as scenes in its factory are printed by way of introduction of plans and policies. One page is devoted to an illustrated description of Polymet advertising literature for retailers.

The Acme Electric and Manufacturing Company, 1444 Hamilton Avenue, Cleveland, features its radio accessories in several new circulars released to retail distributors. Each circular is illustrated with small half-tones of the item which it advertises. List prices are quoted with full specifications. The leaflets have narrow colored borders which attract attention. Space is provided for the dealer's imprint.

The Zinke Company, Inc., Chicago, Ill., sales representative, has released a loose-leaf catalog of its entire line of radio receivers and accessories.

A Window Display for Orthosonic Dealers

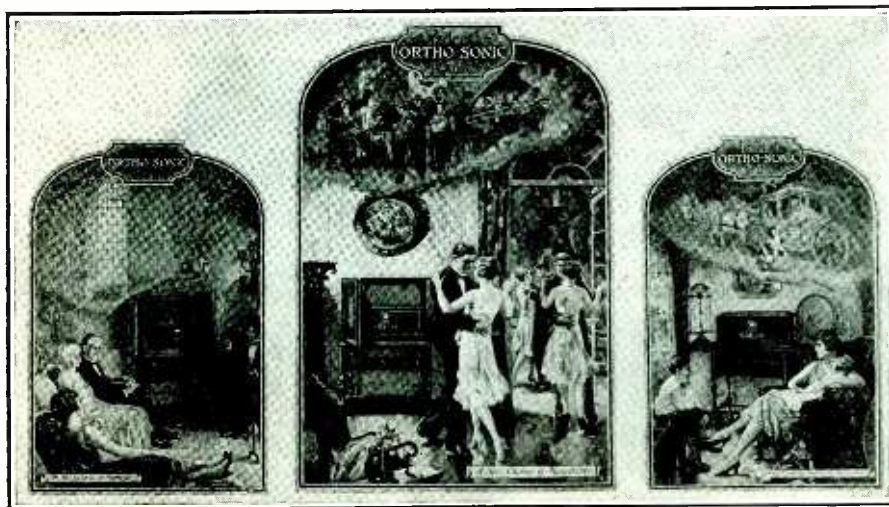

This three panel display is supplied by the Federal Radio Corporation, Buffalo, N. Y. Each one of the three cards is in colors in an oil process

which makes the figures seem lifelike. The cards are washable and are equipped with very substantial easel supports.

The Belden Mascot



This little dial-capped, striped-bodied gentlemen is the Belden mascot. He distinguishes almost every piece of advertising material supplied by the Belden Manufacturing Company, Chicago. This particular easel-backed sales booster is 10½ inches high and is but one unit in the company's latest broadside consisting of two colored counter cards and four separate and distinct folders containing descriptions of Belden products.

The Apco Manufacturing Company, Providence, R. I., has a quantity of advertising material just off the presses with which the retailer may construct an attractive accessory window display. The broadside consists of seven circular window posters, 10 in. in diameter, each poster featuring an Apco accessory, five self-supporting signs upon which sample accessories may be displayed, and several transfer posters identifying the store as an Apco franchise dealer. All these dealer helps are printed in red and blue. The company also supplies a folder in which available advertising mats are shown. Twenty-five of these newspaper mats, ranging from half-page to short single column items, are obtainable without cost.

The Elkon Works, Weehawken, N. J., supplies 24 x 10 in. window display posters printed in red and green, bearing illustrations of the Elkon battery eliminator, small five page folders listing the advantages of this charger and 9½ x 11 in. color reprints from its magazine advertising for use of the retailer. The small explanatory folder is well illustrated in color and may be used as a mail circular.

The Boudette Manufacturing Company, 77 Beach Street, Revere, Mass., supplies a 3½x6-in. counter or window display card as a merchandising aid to be used in connection with the Sonochorde speaker which it manufactures.

F. A. D. Andrea, Inc. features metallic shielding in its latest advertising poster. The chassis of a Fada "8" is pictured against a colored shield over which the explanatory caption "Shield of Protection" is printed. "Harmonated Reception" is the latest note injected into the company's advertising copy which still retains the

familiar Fada colors, orange and black. A second poster advises the window gazer that Fada receivers have been received and are on demonstration. Copies of these dealer helps may be obtained by addressing the company's advertising department at 1581 Jerome Avenue, New York City.

The Central Radio Laboratories, manufacturer of Centralab Radio apparatus, 16 Keefe Avenue, Milwaukee, in its latest dealer help sales bulletin, quotes the *Milwaukee Journal*, which has made an extensive survey of radio sales possibilities in the mid-western market, as follows: "According to figures compiled by the *Milwaukee Journal* in their 1926 survey of the Greater Milwaukee Market, out of every seven radio receivers owned, two were assembled by the owner." The pamphlet goes on to state that the parts business, especially that of standardized merchandise shows every indication of exceeding that of 1926 during the approaching season.

"Animal Crackers"

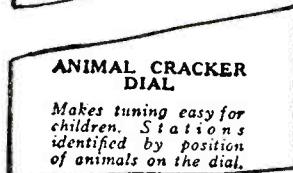
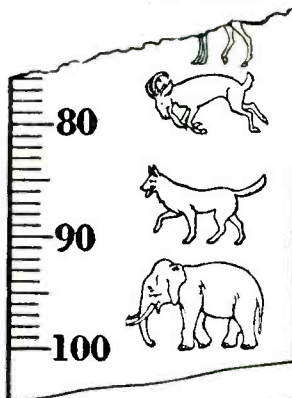

The Crosley Radio Corporation, Cincinnati, furnishes strips which may be placed over the regulation drum dials with which Crosley sets are equipped. Figures of animals next to the dial numbers simplify tuning for children.

The Operadio Corporation, 8 South Dearborn Street, Chicago, features its latest receiving set model, the Operadio-7, in a new four-page folder which may be obtained with space on the cover for the retailer's imprint. The folder contains several half-tones of the set and a number of line drawings illustrating the various uses of a semi-portable receiver which is also adaptable to use in the home. Decorated in red, and containing the list price of the receiver, it provides an effective dealer help for store use, or mailing purposes.

The American Mechanical Laboratories, Inc., 285 North Sixth Street, Brooklyn, outlines the many uses of the Clarostat variable resistance and the Clarotuner tuning coil in its latest sales leaflet called "Control." The leaflet is printed in two colors, contains illustrations of the devices with prices, and fits in a standard envelope for mailing purposes.

The Freed-Eisemann Radio Corporation, Brooklyn, N. Y., furnishes a booklet containing photographs of its entire line of sets and accessories, printed and illustrated in a manner which adapts it particularly for use as a retail sales pamphlet. Color is employed in all half-tone illustrations and list prices are included in the description of each item. Cuts of two of the companies period model cabinets form good front and rear cover illustrations.

The Insulating Company of America, Inc., manufacturer of insulating materials, has released a catalog containing a list of the principal items which it will manufacture and distribute during 1927. The company's line includes practically every article made of Bakelite or Insuline used in the construction of radio receivers, including drilled and engraved panels and sub-panels for seventy or more popular receivers. Retail prices and illustrations are included in the catalog.

The Radio Appliance Corporation, 4884 North Clark Street, Chicago, has prepared a small two-color leaflet which contains full specifications of its new Console Fiat Loop. The leaflet outlines the features of the new loop in an interesting manner, contains the list price of the accessory and is photographically illustrated. It is 6x3½ in. overall and has a blank space on its cover for the insertion of retailer's name.

The Workrite Manufacturing Company, Cleveland, O., provides a dealer help which may be used as a sales booster in its new folder outlining the features of the new Workrite Neutrodyne. The pamphlet contains list prices and colored photographs of the company's three models. Space is provided on the cover for the dealer's name and address. The artistic method of illustration employed in the folder is certain to attract attention.

The Western Coil & Electrical Company, Racine, Wisc., is distributing three leaflets which may be used by retailers as mailing circulars or counter catalogs. Each circular contains photo illustrations of one of the company's Radiodyne receiver models.

Featuring Jewell's Line



Six measuring instruments for radio use are included in this attractive counter carton distributed at the price of the meters alone by the Jewell Electrical Instrument Company, Chicago. The carton is fitted with compartments for each meter and is decorated in red and black. Two types of cartons are available. No. 800 is especially made up of articles interesting to the general radio dealer, while No. 800-A contains items more easily saleable by the music-radio dealer.

CROSLY 1927 RADIOS

Each set giving the utmost in radio enjoyment at its price. All prices slightly higher West of the Rocky Mountains. All prices are without accessories.

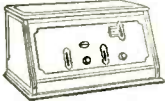

The 5-50 — \$50

Enthusiastic owners report amazing performance—a drum delivering stations loud, clear and sharp; each an almost imperceptible turn of the drum apart. Write station letters on drum, return to them at will. Single Drum Station selector.



The 5-75 Console—\$75

This set includes ideas for Radio reception perfection not found in any other radio. Marvelous exclusive Crosley "Crescendon" and "Acuminators" increase volume on distant stations and bring in programs entirely missed and passed by on ordinary one-dial control radios. Console model stands 40 in. high. The Crosley Musicone is skillfully built into the cabinet in a manner which is both an artistic and an acoustical triumph.



"6 Tube RFL-90" Console, \$90

Introducing the double drum station selector! Crosley's winning non-oscillating perfectly balanced tuned radio set. Includes Musicone skillfully built into exquisite console mahogany cabinet of two-tone finish to match finest surroundings. Room for batteries and all accessories; 40 in. high; 30 1/2 inches wide.



CROSLY MUSICONE
The secret of perfect reproduction of all audible sound lies in its actuating unit. There is only one genuine musicone. It is built solely by Crosley.



CROSLY 1927 FEATURES

Many exclusive—others found only in highest priced radios.



"—as long as I can pick up 27 programs in 30 minutes beside our 3 locals interference won't bother me

I sat down the other night with this Crosley set. One control. Beginning at one end of the broadcasting wave band, I tuned in 27 stations, loud and clear, just like the Cincinnati stations, three of which were going full blast. I listened to each program; identified it; didn't hear any others in the background, and passed on to the next,—all with one finger. It was between 7:00 and 7:30 P. M. Central Standard Time.

The air was certainly full. Some of the stations were less than a dial marking apart. It is amazing how the jiggers they call "acuminators" helped on such fine separation.

Even using a hundred foot aerial the local stations were easy to go through. One of them only a few blocks from my home.

Some radio, I call it! \$50.00 seems too little. I'd like to see some two hundred dollar sets do as well!"

Write Dept. 130 for Catalog

The Crosley Radio Corporation

Powel Crosley, Jr., Pres.
CINCINNATI, OHIO

Crosley sets are licensed under Armstrong U. S. Patent No. 1,113,149, or under patent applications of Radio Frequency Laboratories, Inc., and other patents issued and pending.

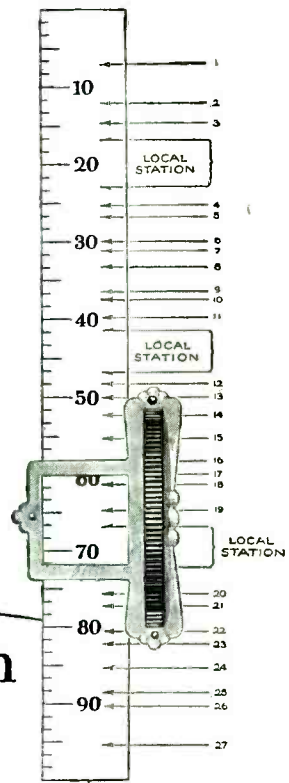

Single Drum Control
\$ 50.
Prices slightly higher West of the Rocky Mountains.

The above scale reading shows how stations picked up by Mr. X—appeared on the Crosley graphic drum station selector. Name on request.



THE "CRESCENDON"

When, on ordinary radios, ears must strain to catch a station miles away, a turn of the Crescendon on Crosley radios instantly swells reception to room filling volume. An exclusive Crosley feature.

ALL-METAL SHIELDED CHASSIS

This truly great radio achievement, found in several Crosley sets, furnishes a substantial frame for mounting elements, produces excellent alignment of condensers, shields the units from each other, prevents interstage, im-

proves the stability of the circuit, increases selectivity and saves costs by standardizing this phase of manufacture.

THE SINGLE-DRUM STATION SELECTOR
Nothing in radio equals the joy or the convenience of single drum control. Crosley single

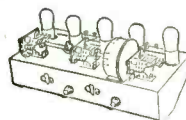

drum control enables you to find the stations sought without log book or "tuning."

POWER TUBES

Power tube adaptability marks the Crosley "5-50," "5-75" and "RFL" sets. This feature typifies Crosley provision for best radio reception at moderate cost.



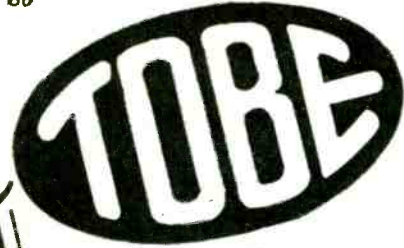

Radio Interference Filter No. 1

Radio Retailing tells the Serviceman, in its Jan. 1927, number, what can be done to eliminate oil-burner interference and outlines apparatus necessary.

Here it is, ready to use. The TOBE Interference Filter No. 1 is an appliance which filters oil-burner interference. It works on refrigerator, washing machine and other household motors, too, and takes up to 1/4 H.P. It incorporates features preventing damage to commutators through sparking. The price is \$15.00 list. Dealers and manufacturers, write us for discounts.

Send for Bulletin R-2

Tobe Deutschmann Company
Cambridge, Mass.

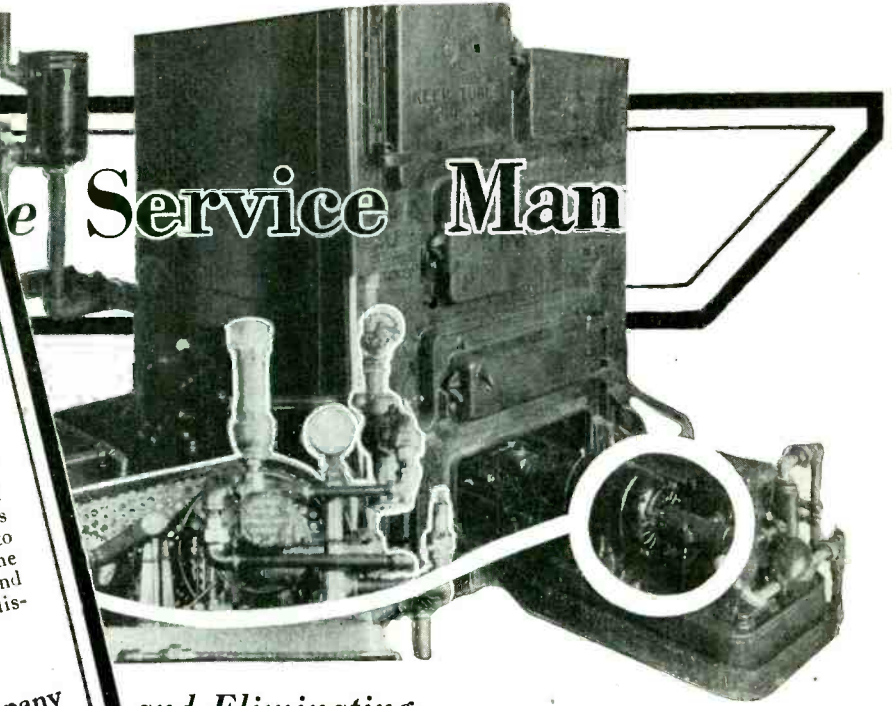

Service Man

and Eliminating Oil Burner Interference

With bet stat and less But man, as usual, steps in and disrupts the natural course of events, so that as nature eases up on the static he proceeds to make some.

In this particular case we refer to oil burners for the furnace which have come into very popular use within the past few years. Trouble from this source is evidenced by a continuous frying or crackling noise in the radio set, which may continue for thirty or forty minutes at a time, and sometimes longer. There are a number of oil burners now on the market that use a universal type motor connected to a blower or centrifugal sprayer device. This type of motor uses a commutator with brushes continually bearing down upon it. After a short time this commutator becomes dirty and much sparking occurs at the brushes. Even a new motor will sometimes spark quite a bit. The result is interference to all close-by radio receivers. It has been found that the interference will at times travel for a block or more each way from its source.

Oil burners which use a repulsion induction motor do not cause radio interference.

After finding this source of interference, the next step is to clear it up. On offending series motors it has been found that the filter shown in the accompanying sketch will usually entirely eliminate the interference.

A Department of Service Helps
Conducted by
H. W. BAUKAT

To construct filter such as this take two porcelain tubes approximately 1 in. in diameter and 12 in. long, and on each of these wind 175 turns of No. 16 D.C.C. wire. This size of copper wire will pass all the current necessary for the operation of a 1/4-hp. motor, the size most commonly used in oil burners. The number of turns, as well as the size of the by-pass condenser, will have to be determined by experiment for each job, since, experience shows, no set rule can be laid down that will be equally effective on every motor. However, the figures given here can be used as a basis in most cases. After the coils are wound, they

should be mounted on a 7 in. x 14 in. bakelite panel and the whole device put in a metal service box measuring 10 in. x 16 in. x 4 in. The two by-pass condensers, whose capacities may vary anywhere from 1 to 8 mfd., can also be put in this box and their mid-point grounded. Sometimes it is necessary to shunt an additional condenser as shown on diagram below.

Where the interference is not too bad, an 8 mfd. condenser shunted directly across the brushes of the motor often will effectively stop the interference. Put the condensers and chokes as near the brushes as possible.

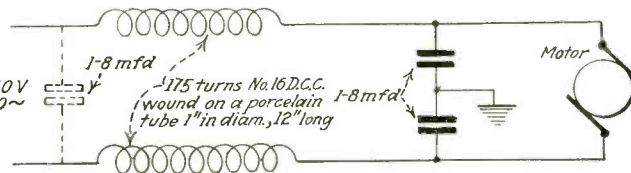

Above is the wiring scheme for checking interference from universal type oil burner motors.



Merchandising Radio Parts

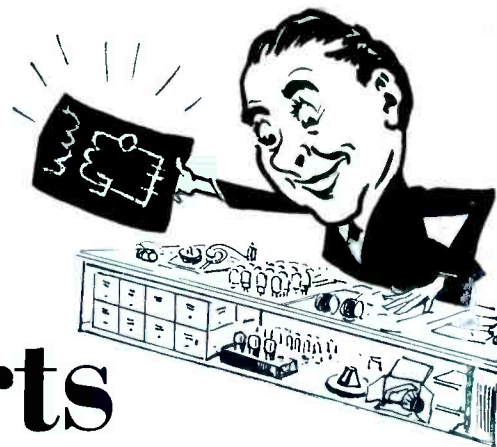

A Section of *Radio Retailing*

February, 1927

How Parts Dealers

Feature New Circuits

The appearance of new and improved circuits for sets, battery eliminators and other units designed for the home-builder influences the sale of parts more than any other factor. A good rule for the retailer is, "Boost new circuits to sell parts."

THE appearance and popularization of new circuits for the home-builder of sets, battery eliminators and other radio units constitutes an important factor in the sale of radio parts.

Accordingly many parts retailers have concentrated on "selling" circuits to the consumer before pointing out the merits of parts, utilizing newspaper advertising, window displays and other forms of publicity to stimulate interest in new and improved circuits.

Crowding the Store With Prospects

The Morison Electrical Supply Company, New York City, recently put over a publicity stunt which brought it a "bumper crop" of parts prospects.

Laurence M. Cockaday, popular radio engineer, was engaged by the company to give a short "chalk talk" in the store, outlining methods of construction and operation of his latest receiver. The event was advertised for two successive mornings before Mr. Cockaday appeared, jamming the store from front door to parts counter with interested listeners.

The scheme could easily be duplicated by parts dealers in other sections, replacing Mr. Cockaday with a local radio authority or the store's technical man. The cost is not prohibitive and many sales were made in the store immediately after the talk and for several succeeding days.

In addition to store announcements, window displays and circulars wrapped with each sale a few days preceding the lecture, Morison used only two single column "ads" in a local paper.

Radio Retailing, February, 1927

An equally effective method of attracting attention to new circuits has been used to advantage by Selfridge's, of London. The company's service man was transferred from his workbench at the back of the shop to the store window, where he was put to work constructing and repairing sets using popular circuits.

As each receiver was finished it was placed on a small stand accompanied

by a display card listing the parts used in its construction. A larger card, shown in the foreground of the photo of this dealer's window reproduced on this page, bore the name of the circuit in the process of construction.

Circuit Diagrams Help

Many of the larger parts manufacturers distribute schematic diagrams of circuits in which their products may

Store Talk by Radio Authority Sells Parts

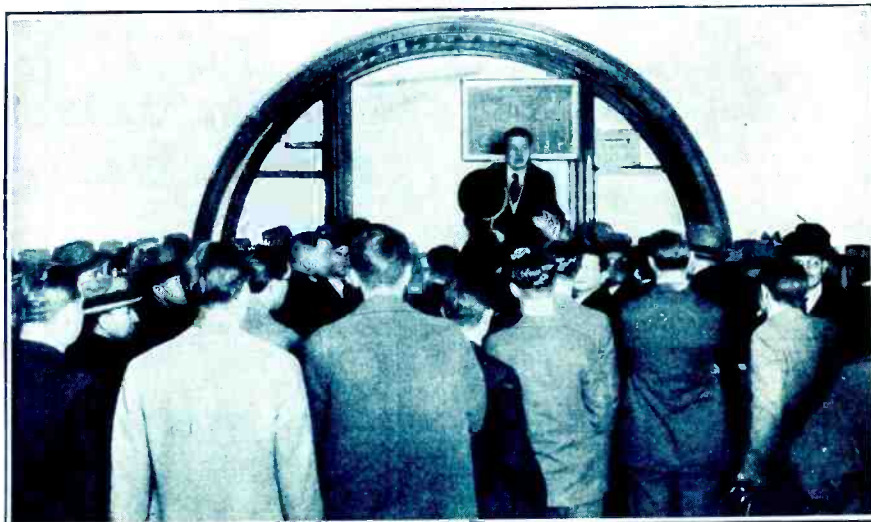

Laurence M. Cockaday, popular radio engineer and designer, is responsible for this gathering of parts fans. He delivered a short talk on the construction of a shielded receiver in the retail store of the Morison Electrical Supply Company, Inc., New York City, recently. A crowded store and many parts sales resulted.

A NEW Amplifier Unit

that provides for Extremely Faithful Reproduction

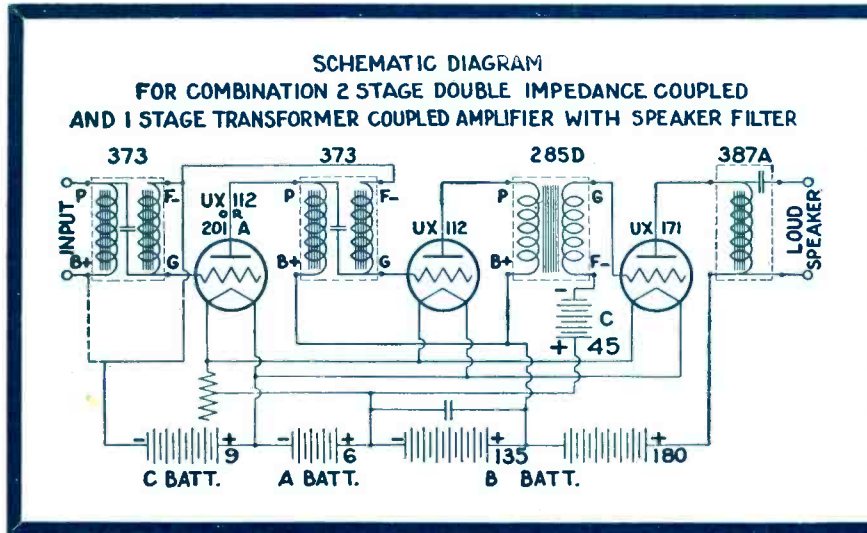

**Type 373
Double Impedance Coupler
Price \$6.50**

While the use of double impedances is not new in principle the General Radio Type 373 Double Impedance Coupler is unique in design and performance. To facilitate installation the complete unit, consisting of two impedances and a fixed condenser, is contained within a metal shell. It is connected in precisely the same manner in an audio amplifier circuit as a transformer.

**Announcing a New
Single Hole Mounting
Rheostat**



The Type 410 rheostats are similar in general appearance and construction to the well known Type 301 rheostat, except that they have the single hole mounting feature, and a flanged knob, with engraved pointer of moulded Bakelite.

Furnished with resistances of 6, 12, and 25 ohms.
Type 410 Rheostat..... \$1.25

The extent of its range of even amplification is from appreciably below 100 cycles to over 10,000 cycles, with a gradual downward deviation of slightly less than 7% between 100 and 400 cycles. This deviation in an otherwise perfect amplification curve is so slight as to be practically negligible, because the ear of the average individual can not detect a variation of intensity of much less than 25%.

The amplification curve, in fact, compares favorably with that generally obtained with resistance coupled systems which have the disadvantage of large sacrifices of plate voltages. The General Radio Double Impedance Couplers have the further advantage that when connected as shown in the above diagram, with one transformer coupled stage, they may be used with a properly designed Plate Supply Unit.

Type 373 Double Impedance Coupler	\$6.50
The following parts are used in the General Radio Quality Amplifier:	
2—Type 373 Double Impedance Couplers	\$13.00
1—Type 285-D Audio Transformer	6.00
1—Type 387-A Speaker Filter	6.00
3—Type 349 UX or CX Sockets	1.50
1—Type 410 or 301 Rheostat, 6 ohms	1.25
Complete cost of amplifier parts	\$27.75

If your dealer is unable to supply you with any of the above items, we shall be glad to send them to you prepaid upon receipt of list price.

GENERAL RADIO

Parts and Accessories

GENERAL RADIO COMPANY

CAMBRIDGE, MASS.



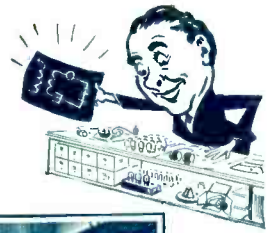

Wiring Sets in the Store Window

be used. Why not wrap one of these diagrams in every package leaving the shop? The distribution of blueprints, printed as part of a monthly advertising circular distributed by a Toronto, Canada, retailer has proved an effective way of securing new parts prospects.

Some of the more recent contributions of radio engineers to the industry such as improved audio amplifiers, loudspeaker filters and battery eliminators could easily be featured in blueprints. Such apparatus would be of interest to many old customers as well as new prospects. Head the display card or circular, "Improve your old receiver—try these new circuits."

Schematic diagrams of new apparatus, taken from radio magazines and newspaper radio sections make effective displays for the store window.

Why not feature a circuit a week in your store window, building an entire display of diagrams, parts and advertising material designed for the new circuit featured?

Small, flat-topped glass display stands used in many retail stores to display merchandise may be used effectively in connection with parts displays. Using a single row of these "stands," followed in step-form by another row composed of two stands placed one on top of the other it is possible to place a quantity of stock in the window without crowding or preventing those in back rows from being seen.

Tie-Up With Advertising

A copy of the day's newspaper "ad" should be placed in the store window. Not only does the "ad" identify the store but it adds to the interest of the display. Parts fans like to examine every new product as it appears on the market and will often stand before a display window until they have carefully examined every article in it. If a number of special parts are featured in the "ad," it also is read by the consumer.

Not only should the parts retailer stock and advertise good merchandise but he should be in a position to aid prospects and customers by understanding the new circuits.

Adapting the Three-Circuit Tuner to Short-Waves

Regenerative receivers of the three-circuit type, tuned by means of a single variable condenser may be used to receive short-wave broadcasting and amateur code signals by connecting a coil, which may conveniently be of the duo-lateral or "honeycomb" type, across the secondary winding of the tuner and placing a variable condenser in series with the antenna. The duo-lateral coil should be placed in inductive relation to the tickler and primary or antenna coils.

Installed in this way, parallel coils reduce the inductance in the main tuning circuit, and the antenna series condenser, in effect, shortens the antenna and reduces coupling. The wave-band which may be covered by such an arrangement depends largely on the type

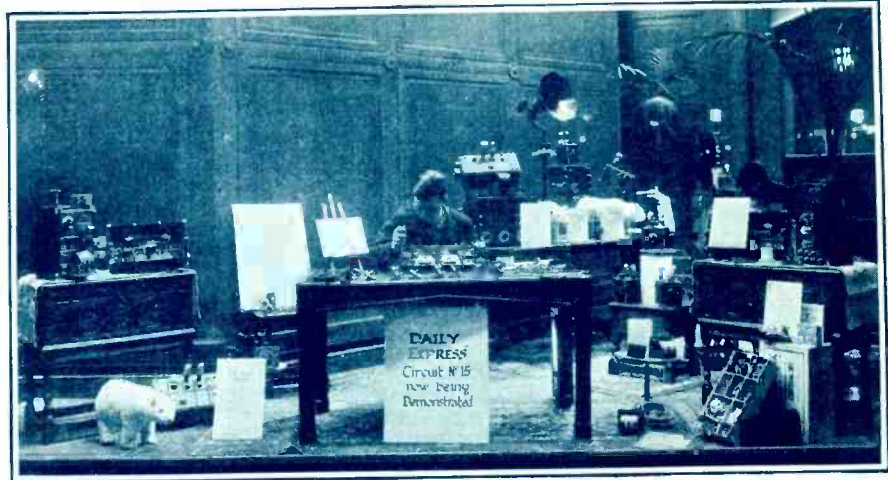

Transferring the service and repair man from his bench in the back of the store to the store window and an appropriate use of display cards created interest in new "Daily Express" circuits for a London, England, retailer.

of tuning condenser already installed in the receiver. In most instances a twenty-five turn "honeycomb" coil shunted across the secondary of such a tuning coil used in conjunction with a .0005 or 23 plate variable condenser will permit wavelengths in the neighborhood of 100 meters to be received. The capacity of the antenna condenser is not critical and it may be almost any size up to .001 mfd.

It may be necessary to use a grid-leak of from 5 to 10 megohms resistance in order to make the receiver oscillate properly at short waves. With some experimenting, solenoid coils may be made to perform the same function. Smaller coils placed in this position will permit lower wavelengths to be received, though this depends largely on the quality and design of the tuning condenser used. Some of the older condensers with "mud" or inferior composition insulation have too high a minimum capacity to permit the operator to tune low enough.

Placing a fixed mica condenser in series with the variable tuning condenser in order to lower the capacity across the secondary coil and thus

tune in short-wave stations, falls short of the mark for this reason. The capacity continually in the tuning circuit is too high. A variable air condenser placed in series with the present tuning condenser often may be used, though both condensers must then be of low-loss, low minimum capacity construction. With such an arrangement the inductance in the circuit is usually too high and tuning becomes excessively critical.

Still better results may be obtained if it is possible to place a spring clip on the lead running to the filament end of the secondary coil, tapping the coil at various points, thus permitting a portion of the coil to be short-circuited when short-waves are to be received. Due to the construction of most manufactured coils this is rarely possible, however.

The first mentioned method provides a way of tuning in short-wave stations without affecting the receiver's performance at broadcast frequencies and should be interesting to customers who already own such receivers. The additional series condenser will also improve broadcast reception. Several of the country's powerful broadcasters employ short-wave apparatus in conjunction with their regular apparatus, broadcasting programs on both bands simultaneously. WLW, Cincinnati, is the latest addition to the ranks of the short-wave broadcasters.

The Carter Radio Company, 300 S. Racine Avenue, Chicago, furnishes a dealer help sheet on which a list of new circuits employing Carter apparatus is printed. The list consists of 30 new circuits in which the designers have specified Carter instruments.

The General Instrument Corporation, 423 Broome Street, New York City, supplies a small counter card upon which one of its "Metralign" variable condensers may be mounted for display purposes.

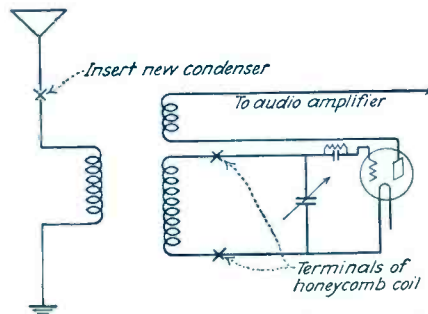

This diagram shows how a coil and a variable condenser may be added to the so-called "three-circuit" tuner so as to permit low wavelengths to be received without making radical changes in the circuit.

“The store that sold me these Faradons sure did me a favor!”



Complete block assemblies for usual eliminator requirements.



Model T. The high efficiency, all metal mica receiving set type unit in desired capacities with convenient terminals. Very compact.



Convenient units for assembly or replacement in special filter hook-ups.



In 1/2, 1 and 2 mfd.

“They told me that the Navy, R.C.A., General Radio Corp., General Electric, Westinghouse, Bell Telephone and many other quality equipment manufacturers all use ‘em; and believe me, I’ve found out that they’re just what I’ve been looking for.”

The store that sells Faradon Condensers is offering a profitable quality item, which will pay dividends in satisfied customers.

Dependability, convenience and long life are built into Faradon Condensers with the accuracy that comes only from years of experience, finest materials and rigid inspection of the finished product.

Sell them Faradons:—

If not already supplied, you can arrange for your Faradons through your usual wholesaler. Write us direct for any descriptive matter desired.

WIRELESS SPECIALTY APPARATUS COMPANY

Jamaica Plain, Boston, Mass., U. S. A.

Faradon

Electrostatic condensers for all purposes

Reviewing the New Circuits

A forecast of construction articles which will appear in March 'fan' magazines

Loudspeaker volume on one tube is claimed for the "Univalve" receiver, to be featured in the March issue of *Popular Radio* as a leading constructional article. The receiver consists of one stage of tuned radio frequency, detector and two stages of transformer coupled audio amplification. The receiver employs a "Multivalve" which incorporates the elements of three tubes in the one vacuum.

- A and B—Auto coupling coils.
- C and D—Variable condensers, .00035 mfd.
- E—Low frequency audio transformer.
- F—Low frequency audio transformer ratio 2-1.
- G—Battery switch.
- H—Automatic filament control unit.
- I—Fixed condenser, .00025 mfd. with grid leak clips.
- J—Fixed condenser, .0001 mfd.
- K—Fixed condenser, .0005 mfd.
- L—Grid leak, 4 megohms.
- M—Single circuit jack.
- Q—Binding posts.

Three Vacuum Tubes in One

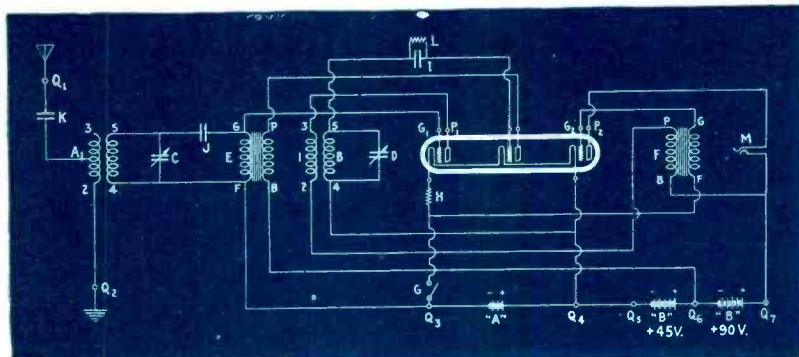

The "Univalve" receiver, designed for the "Multivalve" three-unit vacuum tube by the laboratory of "Popular Radio," operates a loudspeaker much the same as would any three-tube set.

The March issue of *Radio Broadcast* will contain complete instructions for the assembly of David Grimes' latest reflex, the "R.G.S."

The parts used, keyed to *Radio Broadcast's* diagram, are:

- C1—Variable condenser, .00035 mfd.
- C2 and C3—Ganged tuning condensers, .00035 mfd.
- C4—Variable midget condenser, .00025 mfd.
- C5, C6 and C8—By-pass condensers, .00025 mfd.
- C7, C9 and C10—By-pass condensers, .001 mfd.
- T1—Tapped antenna coil.
- T1 and T2—Interstage tuning coils.
- T4—Audio transformer, ratio 2-1.
- T5—Audio transformer, ratio 6-1.
- L1—R. F. Filter coil.
- L2—R. F. Grid Choke coil.
- R1—Rheostat, 2 ohms.
- R2—Variable resistance, center-tapped, 200,000 ohms.
- R3—Variable current-carrying resistance, 24,000 ohms.
- R4—Grid Leak, 1/2 megohm.
- R5—Grid Leak, 2 megohms.

In this circuit employing a power tube, a special "soft detector" and two 201-A's, a modification of the Inverse Duplex system of reflexing permits the operation of four tubes as two stages of radio frequency, detector and three

Radio Retailing, February, 1927

stages of audio amplification, one of which is resistance coupled.

The "R.F.C." Receiver Employing Impedance R.F.

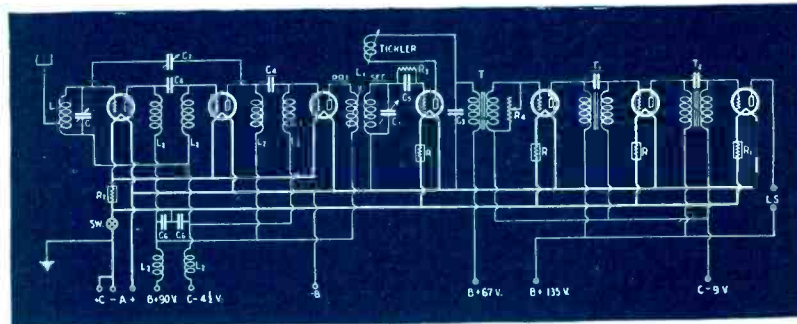

Untuned impedances are used in the radio frequency stages of this seven-tube receiver to be featured in "Radio News" for March as the Sampson "R.F.C."

stages of radio frequency amplification. Key letters in the following list correspond to similar letters on the diagram.

- L—Antenna coupling coil.
- L1—R. F. transformer with variable primary and tickler coils.
- L2—Radio frequency choke coils, 125 millihenrys.
- C—Variable condenser, .0005 mfd.
- C1—Variable condenser, .0005 mfd.
- C2—Variable neutralizing condenser.
- C3—By-pass condenser, .001 mfd.
- C4—By-pass condensers, .0025 mfd.
- C5—Fixed condenser, .00025 mfd.
- C6—By-pass condensers, 1 mfd.
- T—Audio transformer.
- T1 and T2—Dual impedance audio amplifying units.
- R—Automatic filament control resistances, 6 volt, 1/4 ampere.
- R1—Automatic filament control resistances, 6 volt, 1/2 ampere.
- R2—Automatic filament control resistances, 6 volt, 3/4 ampere.
- R3—Grid resistance, 4 megohms.
- R4—Variable high resistance, for volume control, 500,000 ohms.

The David Grimes "R.G.S." Reflex

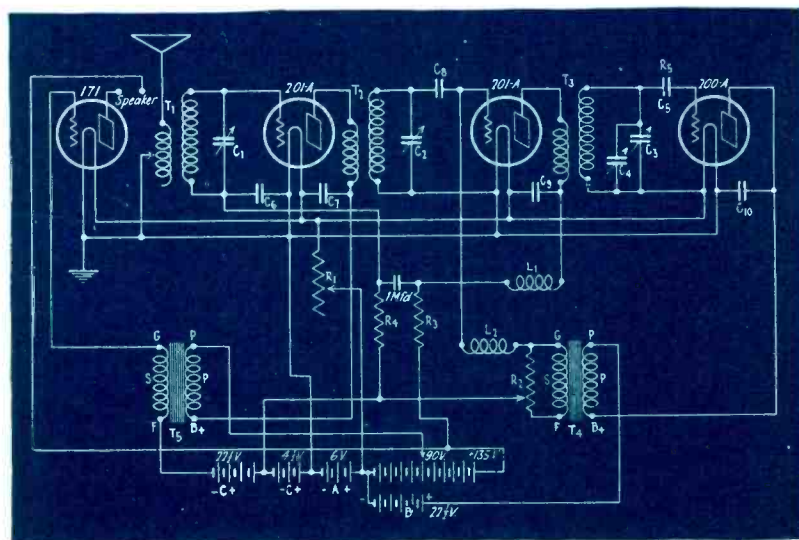

Featured in "Radio Broadcast" for March, this four-tube reflex employs a gang tuning condenser and a separate antenna stage control, permitting two-dial operation.



Radio News for March will contain a complete article on the new Sampson R.F.C. receiver. The set is said to provide excellent tone quality, due to its combination of impedance and transformer coupled audio amplification, combined with the sensitivity of a set employing a regenerative detector and three



Look over the Binding Post that you can sell at a Profit

Eby is the name radio fans have learned to rely upon for binding posts that provide a good and safe electrical connection.

The majority of the famous circuit designers and 90% of the manufacturers have specified Eby Binding Posts exclusively because their experience and experiments have proven Eby's superiority.

To make it easier and more profitable for you we have packaged Eby Binding Posts in individual cartons containing five sets each of all of the markings necessary to build the following receivers—Browning-Drake, Cockaday L C 27, Hammarlund-Roberts, Infradyne, La Cault LRA, St. James, Varion, Kenneth Harkness KH 27 and Victoreen.

These new packages will save your clerk's time, keep stocks down and make inventories easy. Your jobber has them.

LIST PRICE **15c**

Binding Posts **EBY** Sockets

—and Glance at a Socket with real Selling Points

The Eby socket provides a three-point wiping contact, the most scientifically perfect known at all times.

Its ingenious design allows the tube to fairly "float" when in service, thus reducing microphonic noises and protecting the tube against damage.

Eby sockets are specified in the Madison Receiver and Lynch Amplifier. You can sell them profitably at their advertised list price of 50c.

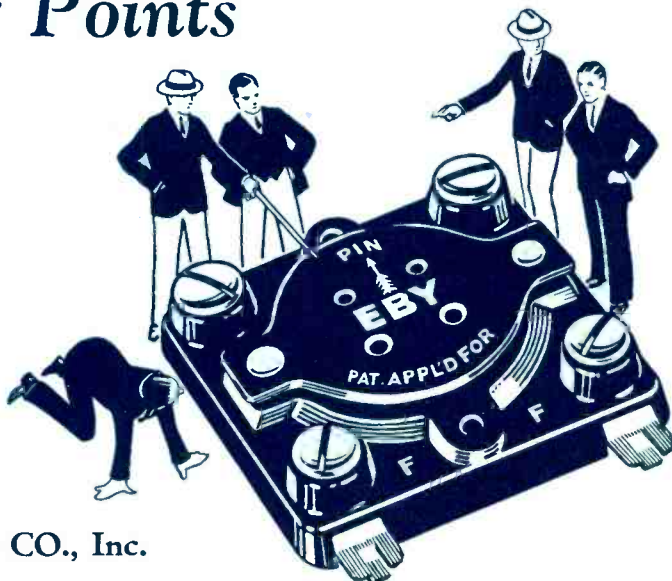

The H. H. EBY MANUFACTURING CO., Inc.
4710 Stenton Ave., Philadelphia, Pa.



New Parts Announced This Month

For additional new parts, sets and accessories see pages 74-78

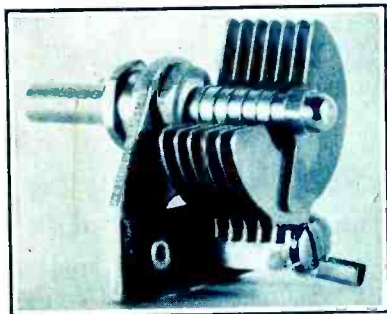

Balancing Condenser with Single Rotor Bearing

Radio Retailing, February, 1927

The "Cardwell Balancet," a small balancing or neutralizing condenser manufactured by the Allen D. Cardwell Manufacturing Corporation, 81 Prospect Street, Brooklyn, is ruggedly constructed of nickel-plated brass with a 1/4-in. shaft. Its insulation is of hard rubber and wide plate spacing insures satisfactory operation without breakdown with voltages up to 2,000 applied across its terminals. The unit may also be used as a tuning condenser in short-wave receivers or as a vernier in conjunction with a larger variable condenser. It employs a single steel bearing for its rotor plates and is manufactured in five sizes, intended retail prices ranging from \$1.25 to \$1.50 each.

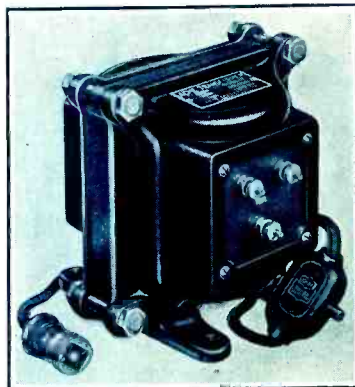

Transformer and Choke for A Socket Power Unit

Radio Retailing, February, 1927

Type A 4 step down transformer and A 5 filter choke coil, manufactured by the Acme Apparatus Company, Cambridge, Mass., are incased in sturdy metal shells equipped with mounting feet as illustrated. Used in conjunction with 110 volt, 60 cycle current and two 2 amp. Tungar rectifying tubes in an "Acme" circuit these units will furnish filament voltage direct from the light lines, for sets employing up to 12 1/2 amp. vacuum tubes. A common 6 volt storage battery is included in the eliminator circuit, operating as a 4,000 mfd. filter condenser across the eliminator output. The battery does not discharge or charge. The intended retail price of each separate unit is \$16.

Balancing Device for Radio Frequency Circuit

Radio Retailing, February, 1927

Electrad, Inc., 428 Broadway, New York City, announces the "Phasatrol," which is designed for stabilizing any radio frequency amplifying circuit, either tuned or untuned. It is mounted in a bakelite case, the adjustment being made by means of a small screw set in the center. Mounting is accomplished by means of one hole in the panel or sub-panel. A small pamphlet showing its use in a circuit is supplied with each device. It is said not to affect the tuning of the set, but to prevent any radiation due to oscillation in the receiving set. Intended retail price \$2.75.



Transformer for Use With Raytheon or Filament Type Tube

Radio Retailing, February, 1927

Universal Transformer No. 355, made by the Jefferson Electric Manufacturing Company, 501 South Green Street, Chicago, may be used as a B eliminator transformer with either Raytheon tube or UX 213 rectification. It is designed to provide 225 volts each side of the center-tap and is also equipped with a 5-volt secondary winding tapped at 2 1/2 volts. This latter winding might also be used to heat the filament of a power amplifier, employing the center tap as a grid-return connection. The transformer is 3 1/2 in. high, 3 3/4 in. wide and 3 1/4 in. deep, and weighs 2 1/2 lb. Equipped with a connection cable and plug, for use on 100-120 volt, 50-133 cycle lines. Intended retail price, \$7.

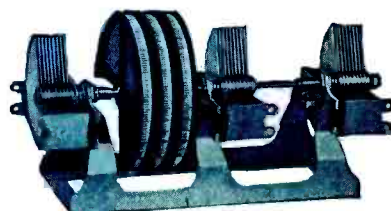
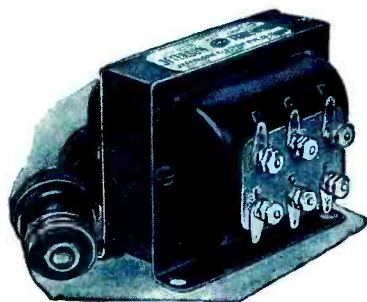

Gang Tuning Condensers with Drum Dials

Radio Retailing, February, 1927

The Alden Manufacturing Company, Springfield, Mass., makes a line of two, three and four unit gang condensers similar to the one shown in the accompanying illustrations, equipped with mounting plates permitting them to be mounted parallel to a receiver panel. Drum dials are provided for each unit known as "Na-aid" localized controls. Radio receivers incorporating these units and otherwise properly designed may be tuned by varying all dials simultaneously. No. 2174, illustrated, is 13 3/4 in. long, 5 in. high and 4 3/4 in. wide. The intended retail price is \$15. No. 7172, the two gang unit, retails for \$8 and No. 2173, consisting of three units for \$10. The dials are of Bakelite, and a panel escutcheon is part of the equipment.

Radio Cabinet

Radio Retailing, February, 1927

The Modernola Company, Johnstown, Pa., manufactures, especially for the parts trade, a line of cabinets for the illustrated type 7 in. high, in lengths to accommodate 18 in., 24 in. or 26 in. receiver panels. A similar line of assembled cabinets is also available to manufacturers of radio receivers.

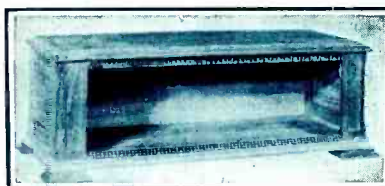

Shielded Audio Transformer

Radio Retailing, February, 1927

The "Meloformer," a 4 to 1 ratio audio transformer manufactured by the Robertson-Davis Company, Inc., 412 Orleans Street, Chicago, is mounted in a 1/2 in. shell of a special alloy. It is 2 1/2 in. high, and the base, made of Bakelite, is 2 in. in diameter. The top of the unit, also made of Bakelite, is 1 1/2 in. in diameter. A special alloy core, solid and split longitudinally, is said to take care of eddy current losses and insure the proper operation of the unit in any audio stage. Intended retail price, \$4.



Six-Tube Shielded Set Kit

Radio Retailing, February, 1927

The "Hi-Q Foundation Unit," marketed by Hammarlund-Roberts, 1182 Broadway, New York City, contains the following basic units for the construction of a Hammarlund "Hi-Q" six-tube shielded receiver: Drilled and engraved micarta panel and sub-panel, two complete metallic stage shields, extension shaft for localizing tuning controls, two equalized fixed resistances, hardware, nuts, screws and wire. Its intended retail price, packed in a carton, is \$10.50.

HAMMARLUND Precision PRODUCTS

Are Officially Specified in these 17 Popular New Circuits

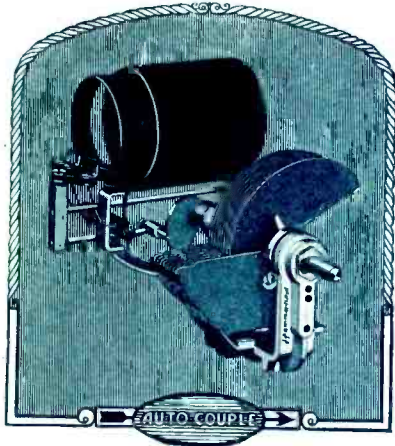

The "AUTO-COUPLE"

A scientific assembly of Space-Wound Coil, "Midline" Condenser and Aluminum Shield, giving automatic, graduated primary coupling at every condenser setting and insuring maximum transfer of energy at each wavelength. Officially specified for use in the new Hammarlund-Roberts "Hi-Q" Receiver, but equally efficient in any other receiver of similar characteristics.

COCKADAY "LC27"
 LOFTIN & WHITE
 ST. JAMES SUPER
 LACAULT "LR4"
 MORRISON "VARION"
 SARGENT "INFRADYNE"
 POPULAR SCIENCE
 MONTHLY "POWERFUL"
 HAYNES "DX2"
 MULTI-VALVE

BROWNING-DRAKE
 VICTOREEN SUPER
 PACENT "ULTIMAX"
 NEW HARKNESS
 HENRY-LYFORD
 CARBORUNDUM SUPER
 HAMMARLUND-ROBERTS
 "HI-Q"
 H. & C. UNI-VALVE

WORLD'S RECORD SUPER

A sure road to profit is open to the dealer who can supply the parts specified for these featured circuits.

Each has a large following of enthusiasts, whose patronage can be won and held by giving them what they want, when they want it.

If your jobber cannot supply you, write to us.

HAMMARLUND MANUFACTURING CO.
 424-438 W. 33rd Street, New York

For Better Radio
Hammarlund
 PRECISION
 PRODUCTS

FROST-RADIO

Ask Your Neighbor

FROST-RADIO RHEOSTATS

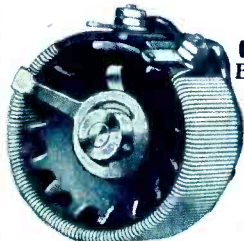

Type 800
FROST-RADIO
 Bakelite Frame
 Rheostat



Type 700
FROST-RADIO
 Metal Frame
 Rheostat

Built on air-cooling cast frame of genuine Bakelite. Current carrying capacity is extra large and it cannot overheat. Operates with easy, silent, non-wearing action. It is the ideal control unit for both new and old type tubes. Supplied in resistances of 2½ to 75 ohms. List price, 75c.

Type 700 is a small, ruggedly built rheostat with a sturdy one-piece metal frame. Has the same electrical and mechanical qualities of our Type 800 Bakelite Rheostat. Cannot warp or bend, and the shaft alignment is permanent. Supplied in resistances of 2½ to 75 ohms. List price, 50c.



Gem

FROST-RADIO
 JACKS
 Jac

The Gem-Jac is small and compact—a wonderful space saver. Projects only one inch behind panel. Springs have self-cleaning sterling silver contacts and the frame is nickel plated brass. A fast-selling little item. Prices 40c to 50c, list



Pan-Tab

The Pan-Tab is without a doubt the DeLuxe radio jack. It has heavier springs, more positive contacts and a finer finish than you will find in other jacks of lesser quality. Arranged for panel or table mounting. List prices, 65c to 90c

HERBERT H. FROST, Inc.

New York 160 North La Salle Street, CHICAGO Los Angeles



Set Manufacturers!

Standards of radio reception are becoming higher with each new year. 1927 models must be an improvement over those of 1926, and they will be.

Correct coils are vital to good reception. We specialize in such coils. We are producing regularly the most advanced types, built with the famous "Diamond-weave" construction.

Write us concerning your own requirements. We are prepared to furnish better coils for the new sets.

THE F. W. SICKLES COMPANY
 140 Union St., Springfield, Mass.

SICKLES DIAMOND-WEAVE
 COILS

The St. James Transformer

The highly efficient vacuum-treated, dehydrated air core transformer which has been so successfully used in the well-known St. James Super-Het.

A mighty good article with good profits for parts dealers. Very complete and simple working plans available.

Send for our Folder



St. James Laboratories, Inc.
 845 Washington Blvd., Chicago, Ill.

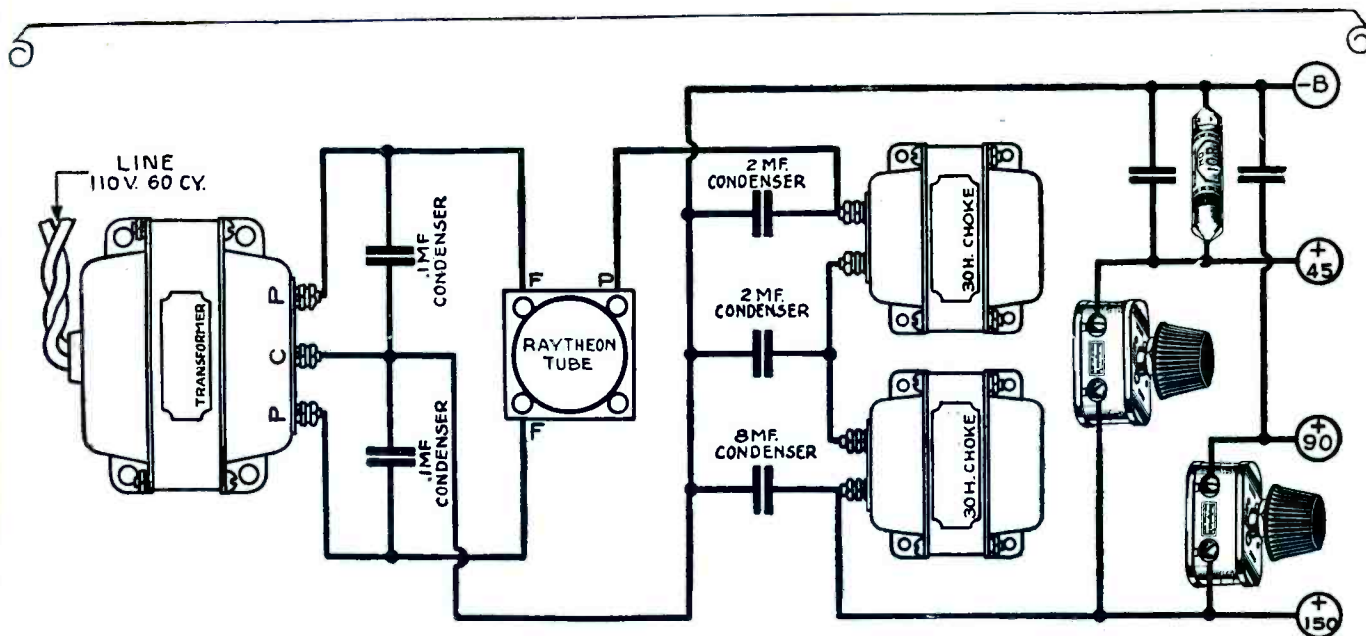

Variable and Fixed Resistors for B-Eliminators

Endorsed by Engineers and Manufacturers

THE best endorsement of a radio product is its use as standard equipment by large manufacturers of radio equipment.

Bradleyohm-E and Bradleyunit-A are used extensively as standard equipment by manufacturers of B-Eliminators. Also, most manufacturers of B-Eliminator kits and coils recommend Bradleyohm-E. Leading radio feature writers strongly recommend Bradleyohm-E for their hookups.

There is a constant demand for these resistors. Get your share of this attractive business by ordering a stock, now!

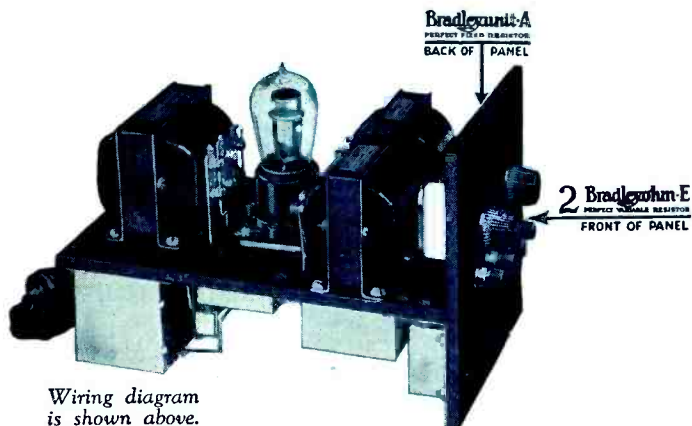

Wiring diagram is shown above.

Bradleyohm-E

PERFECT VARIABLE RESISTOR

Bradleyohm-E is an enlarged Bradleyohm designed especially for B-Eliminator voltage control. The extra long columns of scientifically treated graphite discs insure perfect voltage control over a wide range. It is made in several ranges for various B-Eliminator circuits.

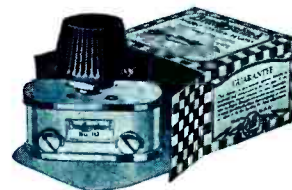

Bradleyunit-A

PERFECT FIXED RESISTOR

Bradleyunit-A is a solid molded resistor for radio circuits. It is molded and heat-treated under high pressure, making it impervious to moisture. The silver-capped ends can be soldered without affecting the calibration of the Bradleyunit.



ALLEN-BRADLEY COMPANY

489 Clinton Street

Milwaukee, Wis.

Sell Allen-Bradley Perfect Radio Devices

SM



Possessing a 3:1 turn ratio, the 220 audio transformer has the highest primary impedance of any known transformer. The impedance values—the criterion of uniform amplification—are 19,000 ohms at 30 cycles and 626,000 ohms at 1000 cycles, approximately.

Look— You'll Find'em

That's the S-M sales story—just that you'll find S-M parts in more and better circuits than any others.

The designers—the men you look to for guidance—have used S-M parts in more than half of this year's circuits.

Would they stake their reputations on anything less than parts they KNEW would satisfy you?

The best recommendation of S-M Parts is the circuits for which they have been specified.

Here are but a few of the more recent ones:

Infradyne (Improved model)
Shielded Six
Silver-Cockaday
Best's A. C. Browning-Drake
Best's A. C. Diamond of the Air
Radio News Batteryless Receiver
Radio Broadcast Super
Radio Age Super
Radio Broadcast Local
LC-27 Junior Power Pack
Citizens Call Book Monotone Receiver
Call Book Power Pack
Callies Super
Radio Mechanics "A," "B" and "C"
Eliminator
Radio Engineering "A," "B" and "C"
Eliminator
Radio Mechanics Man-O-War Super
Lincoln Super
Best's Short Wave Set
Hush-Hush 11 Short Wave Set
Popular Mechanics Super
Christian Science Monitor 6 tube Browning-Drake
Radio Engineering Short Wave Set
New York Sun "B" and "C" Eliminator
for Resistance Amplifier
Chicago American Short Wave Set
Chicago Post Power Amplifier
Best's new Super
Radio News Power Amplifier
Loftin-White
Popular Radio Town and Country Receiver
Radio News Super
Nakken's Ultra-Fine
Cockaday's Pre-Selector
Chicago Daily News Short Wave Adapter

SILVER-MARSHALL, INC.
870 West Jackson Blvd., CHICAGO, U. S. A.

IGRAD CONDENSER UNITS FOR RELIABLE PERFORMANCE

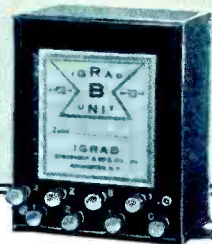

IGRAD Units have gone over big with both manufacturers of sets and "B" Eliminators.

They give a smooth, humless flow of power. IGRAD "B" Units are built under the supervision of engineers thoroughly versed in all the problems of condensers. That is why their reputation for quality is so well established and why they are highly recommended by the Raytheon Mfg. Co.

It will pay you to get the details of these units, which are made up to meet various specifications. Hooked up with the proper accessories or installed in the sets you build, they'll prove big sales boosters.

Prices and Details.

IGRAD CONDENSER & MFG. CO.
26 Avenue D Rochester, N. Y.

Two Automatic Switches

Utility Model

\$200

List

This Reliable Automatic Power Control Switch automatically turns on or off either or both Trickle Charger and B Eliminator when the battery switch on the radio set is turned on or off. Is easily connected to any set from binding posts. Special model sets for using type 199 tubes, list price \$2.50.

Convenience Type

\$350

List

This type of Reliable Automatic Power Control Switch is identical electrically with the Utility Model but has cord and plug and receptacles for quick connection with Trickle Charger and B Eliminator. Special model for sets using type 199 tubes, list price \$3.75.

THE RELIABLE PARTS MFG. CO.
2821 Prospect Ave., Cleveland, Ohio

Write for complete information and trade discounts

Reliable Automatic Power Control Switch

Goodrich Silvertown

The Radio Panel Supreme!

- 1 Easier to drill and machine.
- 2 Better color, lasting lustre.
- 3 Lower free sulphur — no discoloration.
- 4 Higher softening point—no warping.

Goodrich V.T. Sockets Spaghetti Tubing
Radiophone Ear Cushions
Battery Mats
Hard Rubber Tubes for Coils

The B. F. Goodrich Rubber Company
Established 1870 Akron, Ohio

ALUMINUM IS A NECESSITY IN RADIO



The R. B. Lab. 2-tube Receiver, housed in Aluminum is an example of advanced design. The Aluminum Panel combines shielding with beauty.



TODAY the crowding of the air makes shielding essential. Radio has turned to Aluminum for shielding because its properties permit the effective elimination of many of the hazards to perfect reproduction. ¶By using Aluminum for top, base, side and center interstage shield, the designer of the R. B. Lab. 2-tube Receiver has created an effective combination. The 3-32 in. sheet Aluminum Panel is a photographic reproduction of a rare piece of walnut. Hammerlund-Roberts, Silver-Marshall, L. C. 27 and Varion A. C. specify Aluminum for shielding. ¶Alcoa Wing Type Aluminum shields prevent interstage interference effectively and economically. ¶Can-type Shields made of Aluminum are fully effective — individually protecting the various stages. ¶Alcoa Aluminum is effective due to its high durability and low electrical resistance. ¶Used for cabinets and panels Alcoa Aluminum is light, easily worked and is available in the most beautiful wood effects.

Here are some of the Applications:—

Alcoa Shields, Box Shields, Cabinets, Panels, Variable Condensers, High-purity Rod, Foil for Fixed Condensers, Die-Castings, Screw Machine Products.

ALUMINUM COMPANY of AMERICA
PITTSBURGH, PA.



ALUMINUM COMPANY of AMERICA
Room 2322, Oliver Building, Pittsburgh, Pa.

Gentlemen:

Please send me a complimentary copy of the booklet checked on this coupon.

Name

Street

City State

Circuit I now use

Circuit I will build next

Check the square for one, or both, of the booklets you wish.

Booklet

"Aluminum Radio Shields"
A treatise by Cockaday and Free on Radio Shielding.

Booklet

"Aluminum for Radio"
Describes the general application of Aluminum to radio.

Every Radio Frequency Set Needs "PHASATROL"

Licensed by
Hider Radio
Corporation

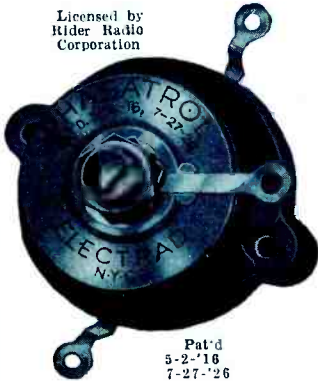

A true balancing device for radio frequency amplifiers.

This is what the radio fans have been waiting for. No fussing with troublesome balancing condensers, no difficulty offsetting coils or transformers, etc., no cussing over radio frequency oscillations — just install PHASATROLS and they will solve these problems in a jiffy.

An extensive advertising campaign, supplemented by wide publicity in the shape of technical articles on PHASATROLS in the various newspapers and radio publications, are creating a big demand for this new device.

Retailing at \$2.75 each, packed six individual cartons to a display container with full instructions for their installation. PHASATROLS sell like hot-cakes. To the dealers who have not yet stocked up, we can give only one piece of advice—if you want prompt delivery so as to meet this demand, order from your jobber TODAY.

ELECTRAD, Inc.
175 Varick Street, New York, N. Y.

ELECTRAD

**These Good Looking Cabinets
Make
Radios
Appear
Better**

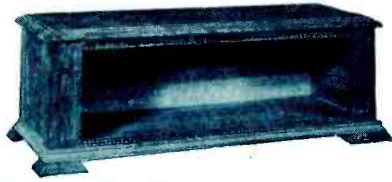

To the dealer who assembles his sets—

We are specializing in cabinets, as shown above to take panels 7 inches high by 18, 24, or 26 inches long. Finished in Walnut or Mahogany.

To the builder of sets in quantities—

We are equipped to manufacture ordinary cabinets, console type cabinets, and tables of all descriptions.

Bids submitted on receipt of blue prints

MODERNOLA COMPANY, Johnstown, Penna.



THE PANEL OF BEAUTY AND SERVICE

No Finger Prints or Smudges.

Distinctive Appearance—Very Popular.

Plain Finish on Reverse Side.

Quick Turnover—Highest Quality—Low Price

HOOD RUBBER CO., WATERTOWN, MASS.

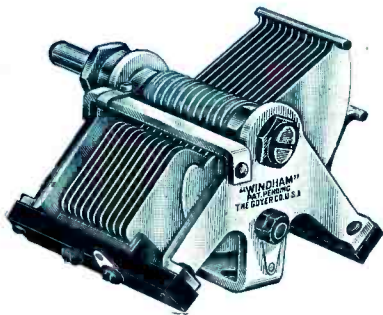

**This season
you must demand more
for your condenser dollar**

Just ordinary condensers will not satisfy your customers. They will insist on a simplified control which will work well between crowded stations. This means the highest quality of materials and workmanship, accurate spacing of the plates and rugged construction to stand constant operation.

Let us show you how the "Windham" condenser measures up to these problems at a cost that will appeal to you.

THE GOYER CO.
WILLIMANTIC, CONN.

CORWICO

Complete Aerial Kits



List

\$1.75

To

\$4.50

Include everything necessary for aerial, ground and hook-up requirements.

"Corwico" complete aerial kits simplify the buying of Aerial Wire, etc. for the set owner and make it easier and more profitable for the dealer to handle antenna equipment.

The six kits in the "Corwico" line list from \$1.75 to \$4.50 to meet the demands of all classes of trade. The higher priced kits contain a Brach Storm King Lightning Arrester with the Brach \$100 guarantee against damage by lightning.

TO DEALERS AND JOBBERS

Be the first in your territory to handle this new kit. Write or wire today for full particulars.

CORNISH WIRE COMPANY

30 CHURCH STREET, NEW YORK CITY

BOSTON: 80 Federal St. CHICAGO: 326 W. Madison St. KANSAS CITY: 208 Baltimore Bldg.
SAN FRANCISCO: 585 Mission Street

**Efficient Service
on Molded Parts**



**BAKELITE AND MOLDED MATERIAL
MADE TO YOUR SPECIFICATIONS**

American Insulator Corp.
52 Vanderbilt Avenue, New York City

DUDLO

MAGNET WIRE AND WINDINGS

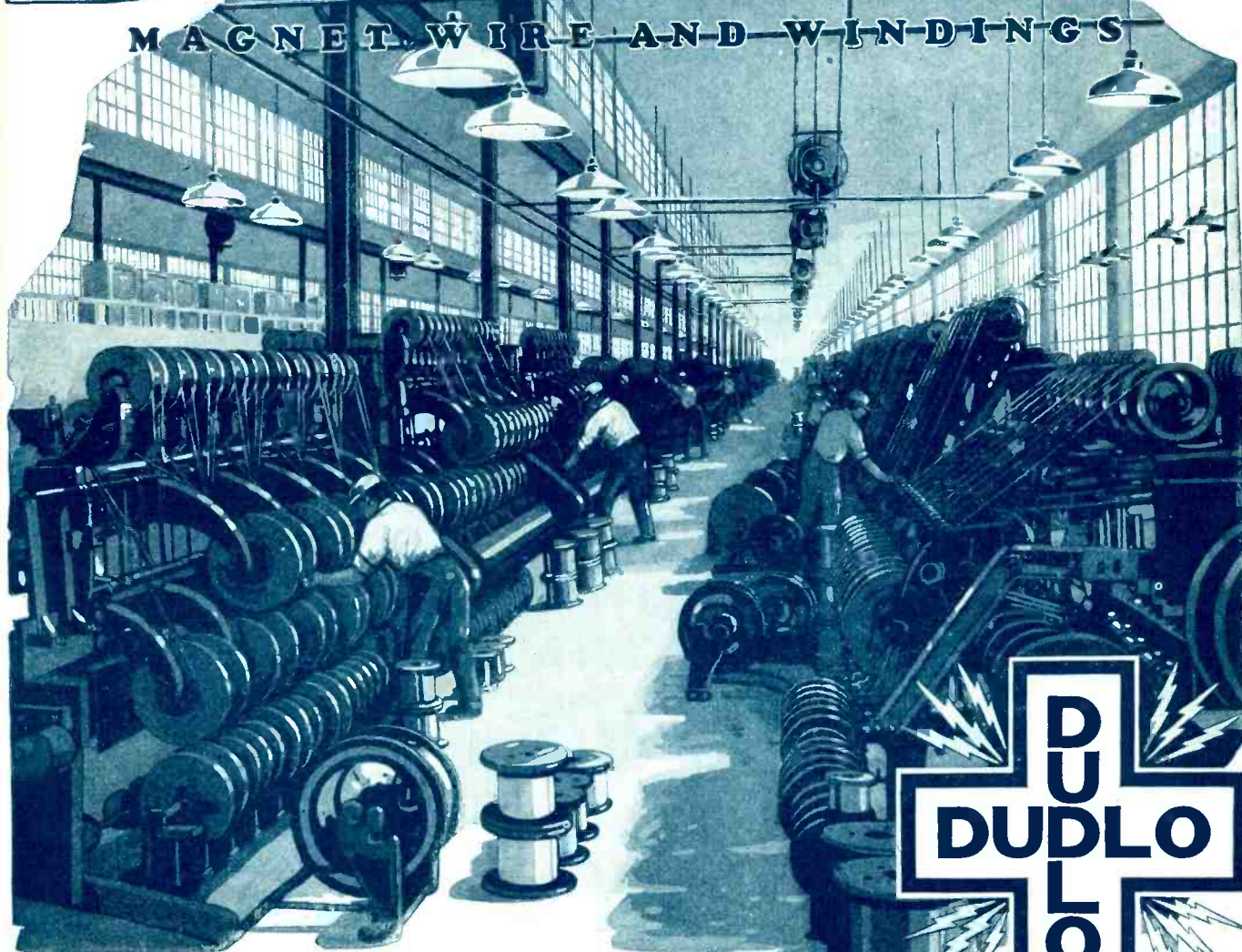

Showing a section of the department in the immense Dudlo factories, devoted exclusively to insulated Magnet Wire.



Uniform and Dependable Insulation Creates a Preference for DUDLO Magnet Wire

Copper wire accurately drawn to gauge from pure copper rod of maximum conductivity is scientifically annealed before being insulated.

¶ A smooth even coating of the finest grade enamel gives the greatest di-electric strength to the smallest possible diameter. ¶ A wrapping of cotton or silk of the highest quality, is wound tightly and closely to insure the most perfect insulation. ¶ Strict adherence to diameter is important. Where Dudlo Magnet Wire is used your winding will agree with your calculations. ¶ Specify Dudlo Wire and be certain of the best quality of copper rod, and the finest grades of insulating materials, uniformly and compactly wound.

DUDLO MANUFACTURING CORPORATION, FORT WAYNE, INDIANA

412 CHAMBER OF COMMERCE BLDG.
NEWARK, N. J.

160 NORTH LA SALLE STREET
CHICAGO, ILL.

4153 BINGHAM AVE.
ST. LOUIS, MO.

274 BRANNAN ST.
SAN FRANCISCO, CALIFORNIA

Quality

The Key to the
1927 Buying Trend

FERRANTI

NOW, more than ever before, radio fans are realizing that it is false economy to skimp when buying transformers. On transformer quality depends the quality of the entire set—and that's why critical radio buyers are swinging around to Ferranti. The few extra dollars they pay for Ferranti come back to them a hundredfold in increased radio enjoyment.

Permanent reliability and sound construction . . . true rendering of all notes in the scale . . . straightforward and honest merchandising policy . . . co-operative advertising — these Ferranti features take the transformers off your shelves and keep them in the buyers' sets.

When a fan walks into your store and asks for the best, give him the best—Ferranti! It means a handsome profit and increased prestige for you!



A. F. 3 . . . The best \$12
transformer at any price

FERRANTI, Inc.

130 West 42nd Street, New York, N. Y.

Ferranti, Ltd.
Hollinwood, England.

Ferranti Electric, Ltd.
26 Noble St., Toronto, Can.

Radio Retailing again proves its Leadership!

"What Radio Publication has the *greatest* influence with you in selecting the various radio parts for your stock?"

A questionnaire asking this question was recently sent to 1,000 radio parts retailers by a leading manufacturer.

The results show that RADIO RETAILING is the choice of more dealers than all other publications combined, despite the fact that many of the "Fan" Papers have circulations running into hundreds of thousands.

Of the 352 dealers responding,

226 mentioned RADIO RETAILING,
29 mentioned Magazine No. 2, a "Fan" Paper,
25 mentioned Magazine No. 3, a "Fan" Paper,
23 mentioned Magazine No. 4, a Radio Trade Paper,
18 mentioned Magazine No. 5, ELECTRICAL MERCHANDISING,
9 mentioned Magazine No. 6, a "Fan" Paper,
8 mentioned Magazine No. 7, an Elec. Trade Publication,
7 mentioned Magazine No. 8, a "Fan" Paper,
3 mentioned Magazine No. 9, a "Fan" Paper,
3 mentioned Magazine No. 10, a "Fan" Paper,
1 mentioned Magazine No. 11, a Radio Trade Publication.

Here again is overwhelming proof of the Leadership of RADIO RETAILING. An unbiased and straight-thinking editorial policy, plus complete coverage of all worth while outlets, has put RADIO RETAILING far in the lead.

Radio Retailing

A McGraw-Hill Publication

10th Ave. at 36th St., N. Y. C.

ASSEMBLY ECONOMY

— the new big idea in little Condensers

MIDGET TYPE fixed condensers—by SPRAGUE—bring a new day in circuit wiring. Their flexibility—their adaptability to every wiring problem—is making new economies and better standards in today's assembling factories.

Midgets, with the electrical hearts of giants. Factory tested at 1500 volts—higher uniform breakdown—(3550 volts A. C. in recent tests)—constant capacities—insulated casing—one-fourth the weight—half the size. These are the features of the new easiest-to-wire condensers.

With the time-saving pre-soldered lugs the midgets are fitting into sets everywhere—and anywhere—discarding screws, nuts, bolts, drilling—and wire, too.

You can discover how these condensers will increase set efficiency and short cut to lower assembly costs. Your address is enough to bring you the entire story.

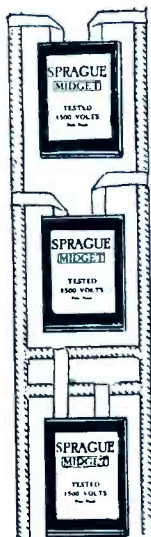

Our service department will welcome the opportunity of studying your wiring and condenser questions. A letter from you will bring back samples and some money saving assembly ideas. Write Dept. R.



SPRAGUE SPECIALTIES CO.
QUINCY, MASS.

SPRAGUE MIDGET CONDENSERS

Your Coil Problem Solved!



Install a group of "Universal" Coil Winding Machines and insure uniform production of dependable coils at surprisingly low cost



Purchase these same coils from us, carefully wound to your specifications and ready for application to your product

UNIVERSAL WINDING COMPANY
LESSONS
BOSTON

Vee Dee



Art Metal Panels for Kits and Sets

Manufacturers and Jobbers

Save money and improve your sets by adopting Vee Dee Metal Art Panels. We cooperate in working out new panel designs. Lowest prices — liberal terms.

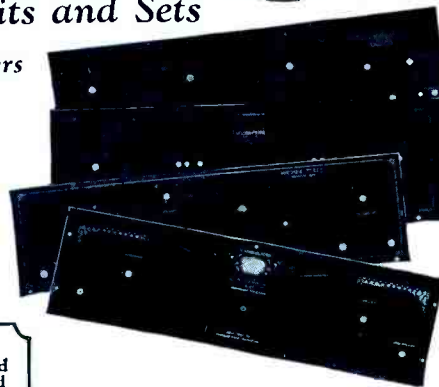

for Nationally Famed Kits—Drilled and Decorated

- L. M. Cockaday LC-27, \$3.70
 - Browning-Drake Improved, \$3.05
 - Hammerlund-Roberts Hi-Q, \$2.70
 - Silver-Cockaday Panel and Chassis, \$4.60
 - Karas Equamatic, \$3.50
 - Infradyne-Remler Type, \$3.75
 - Bremer-Tully Power Six, \$3.05
 - Citizens Super Panel and Chassis, \$6.60
- Write for Discounts

Receivers equipped with Vee Dee metal art panels will yield the utmost in efficiency, accuracy, durability, beauty and economy. Vee Dee Metal Panels are finished in beautiful wood grains, bronze duo-tones and high lighted novelty effects. Precisely drilled to the thousandth part of an inch. Every special panel includes vulcanized fibre bushing for best insulation.

STOCK METAL PANELS

In all standard sizes. Easy to drill. Retail prices range from \$2.15 to \$3.55. Beautifully finished and artistically decorated.

WRITE TO

The VAN DOORN COMPANY
160 North La Salle Street, Chicago, Ill.
Factories, Quincy, Ill.



\$7.00

Stock up NOW on Karas Harmoniks for the new and novel "Three-Tube-in-One" Set



RADIO set builders, both professional and amateur, will want all the information they can get about the audio frequency transformers they will buy for their novel Univalve Set which will be fully described in the March issue of *Popular Radio* and in which ONE ONLY Karas Harmonik is used. They are especially interested in definite technical data on impedance, distributed capacity, etc. We give a great deal of such information not generally furnished by audio transformer manufacturers in our literature about Karas Harmonik All Stage Ratio Audio Frequency Amplifying Transformers. We'd like to send you a generous supply of this Harmonik literature for distribution to your parts customers. Write for it today. Meanwhile, lay in a stock of these remarkable Harmonik Transformers. Discriminating fans prefer them to all other makes because they know Harmonik volume, freedom from distortion, and purity and sweetness of tone. If your jobber is out of stock you can order a dozen Harmoniks direct from us by filling out and mailing the coupon below.

Fill Out and Mail Coupon Today

Your store should handle fast-selling Karas Harmoniks because of their greater popularity, larger profit and tremendous satisfaction. So use the coupon today to order 12 Harmoniks, as well as a supply of our interesting literature. Fill out and mail the coupon while this page is before you—NOW.



KARAS ELECTRIC CO.
1001 Association Building,
CHICAGO

Karas Electric Co.,
1001 Association Building, Chicago.

- () Please ship me 12 Karas Harmonik Audio Transformers C.O.D., list price, \$7 each, less dealer's discounts.
- () Please send me a supply of your Karas Harmonik Circulars containing complete technical information about these transformers, and I will give these circulars to my parts customers.

Name
Address
City State
(If cash accompanies order we prepay carrying charges.)

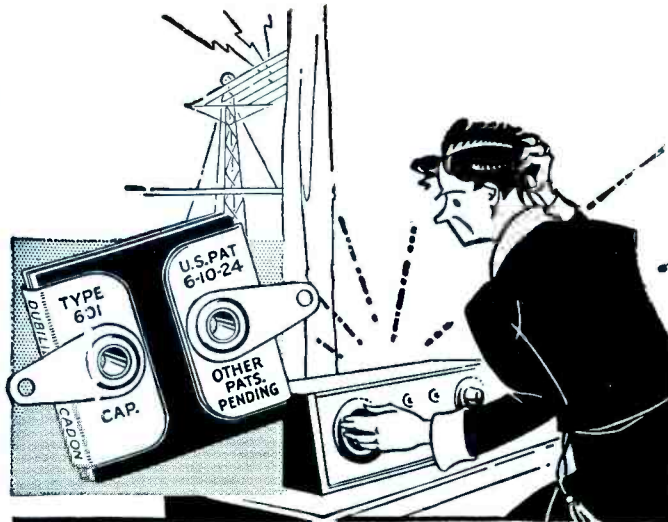

Can't tune 'em out?

Difficulty in tuning out nearby stations is a real problem for almost every radio listener in these days of uncontrolled broadcasting. You can help your customers and help your sales, too, if you will use Dubilier's method of telling them the things they ought to know about radio.

A Micadon 601 in series with the antenna has the same effect as "loose coupling" and will relieve all except the worst cases of interference. *The Dubilier 32-page booklet "Seventeen Ways to Improve Your Set"* tells about this and sixteen other uses of fixed condensers. It will help you to sell not only condensers but other parts as well. Fourteen thousand radio fans sent 10c for this booklet the first month it was published.

You can get a supply of these booklets for sale or for distribution from your local jobber.



Dubilier

CONDENSER CORPORATION

4377 BRONX BLVD. NEW YORK, N. Y.

"The Most Amazing Achievement of Radio Science"



Says - MOISSAYE BOGUSLAWSKI - World Famous Pianist

MOISSAYE BOGUSLAWSKI
Studio
64 E. Van Buren St.
Chicago

ERLA Begins Where The Latest Improved Phonograph Leaves Off

That is the impression received by Mr. Boguslawski after hearing this wonderful radio receiver. This master musician knows tone quality—read his letter again. Just visualize the sales possibilities of this outstanding radio line. Offers everything desired of a radio receiver. A franchise will protect you and assure you real profits. Write or wire today for complete data. Address Dept. F50, 2500 Cottage Grove Ave.

Moissaye Boguslawski's programs are enjoyed by thousands through Station KYW



December 10, 1926
Electrical Research Laboratories,
2500 Cottage Grove Ave.,
Chicago, Illinois

Gentlemen:

Today I had a genuine musical thrill--I listened to the Erla "Super-Six"! It begins where the latest improved phonograph has left off. The Erla produces the true voice of the singer, retains the individual tone of every orchestral instrument, and the most amazing achievement of radio science--the piano tone comes in with all its ravishing beauty, singing quality--sonority and brilliance! "Erla-tone" should be added to the terminology of music's greatest names, along with Beethoven, Wagner, and Chopin.

My heartiest congratulations upon the perfection of Erla-radio's most faithful producer of music as the sincere artist broadcasts.

Sincerely yours,

Moissaye Boguslawski

ELECTRICAL RESEARCH



LABORATORIES, CHICAGO

Do your customers *believe* you?

Do they? Do they look upon you as a local radio authority—as one whose recommendations are safe to follow?

Or have you changed lines so often and claimed superiority for so many makes that your customers don't know where you do stand?—and you sometimes wonder yourself!

Have you been confused by the multiplicity of manufacturers' claims, disappointed by their failure to make good, hung up with "orphans," forced to lose profits as well as prestige?

Or are you one of those who are satisfied with things as they are?—one of those who at the very beginning, lined up with Federal, who relied upon Federal's established reputation for stability and permanence, and who today are cashing in?—Yes, one of those, and there are hundreds of them, who are now *believed* by their customers!

* * * *

The Federal designation offers you an exclusive line of radio—the *only Ortho-sonic* radio—nationally advertised, nationally accepted and with an all-inclusive price range.

It offers you beauty of cabinet design alone such as to make Federal predominate wherever it is displayed and properly pushed.

More than all that, it offers you permanence of parent organization—something you can bank on *now*, something you can build on for the future. And surely nothing you can think of is more worthwhile than that!

If you are not already in the Federal fold, get the whole story. Find out about the Federal designation—about its advantages to the retailer, its profit-insuring features, its liberality and protection and freedom from red tape.

Federal is being successfully handled by the very cream of the retail radio trade. The proposition offered is the most unusual in the industry. Get in touch with your Federal wholesaler at once. If you don't know him, write us for full particulars. Do it TODAY.

The sign of the
Designated Federal Retailer



FEDERAL RADIO CORPORATION, Buffalo, N. Y.
(Division of Federal Telephone and Telegraph Co.) Operating Broadcast Station WGR at Buffalo

ORTHO-SONIC*

Reg. U. S. Pat. Off.

Federal Radio

* The fundamental exclusive circuit making possible Ortho-sonic reproduction is patented under U. S. Letters Patent No. 1,582,470

Hook Up With This!

SUPERB! "A" ELIMINATOR

—and you will
"dial" these!

1. Comes ready to use—just attach to light socket.
2. Hooks up like ordinary battery.
3. No change in wiring needed.
4. Operate automatically with switch on set. No extra wiring or change in wiring already in use.
5. Operates any standard set including Resistance and Impedance Coupled types. Loop or outside aerial.
6. Not a trickle charger.
7. Perfectly quiet. No audio frequency whistles.
8. Absolutely dry, nothing to spill.
9. No delicate parts whatever to get out of order.
10. Also supplied in combination with "B" and "C" units if desired, making one complete power outfit.

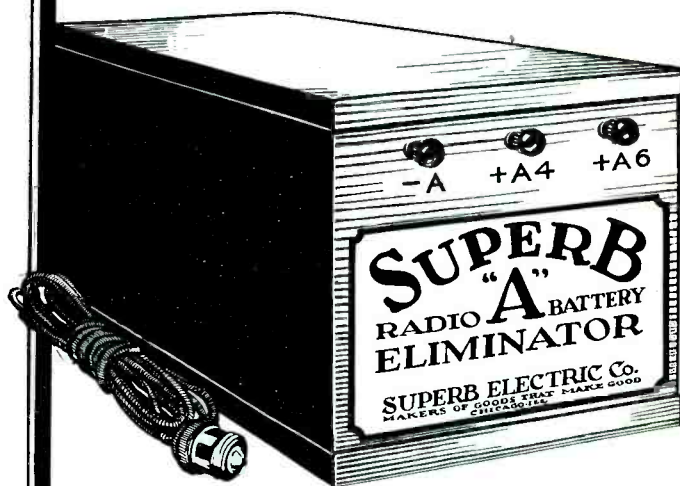

A Nation-Wide Consumer Good Will has already been purposely created for you by our widely-distributed and nationally-advertised Superb "B" Eliminator.

For special price offer on one sample outfit to Bona-fide Dealers, tear off and send the coupon attached below.

SUPERB ELECTRIC CO.
"Makers of Goods That Make Good"
220-222 N. State St., CHICAGO, ILLINOIS

SUPERB ELECTRIC CO.
220-222 N. State St.
CHICAGO, ILLINOIS.

Gentlemen:
Name
Address
City

Sell—

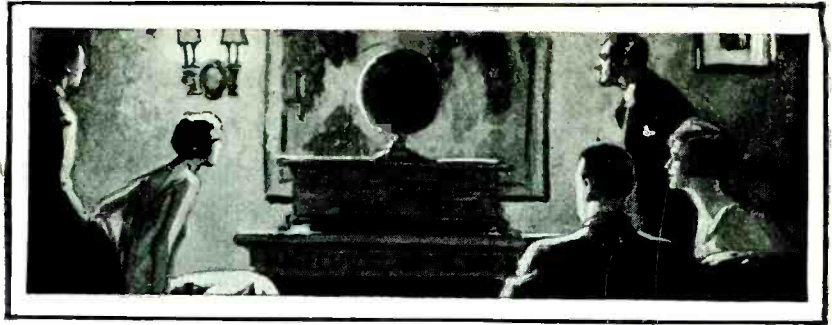

Sterling "B" Eliminators and you are selling Tone Quality plus Sterling Dependability

—and there's
a Sterling to suit
every type of set



Models
R-97 and
R-99
using
Raytheon
Tube
Type B. H.

Sterling Model R-97 gives 180 volts at 50 mills. and has two "C" taps for power tube and other "C" voltages.
List Price..... \$55.00

Sterling Model R-99 gives same output but has no "C" taps.
List Price..... \$45.00

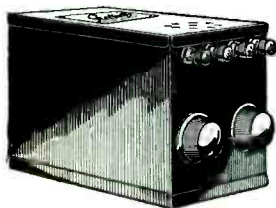

Model
RT-41

Sterling Model RT-41 is recommended for sets of not more than 5 tubes, gives 130 volts at 20 mills., uses CX-313 type tube, has adjustable detector and amplifier voltages. In size and power is ideally suited to Radiolas No. 25 and No. 28.
List Price..... \$28.00

STERLING "B" Power units offer you new selling points, vital owner advantages that will interest every "B" eliminator prospect.

The Sterling is different—different in that just the right adjustment of "B" or "B" and "C" voltages can be obtained to suit any set. And this superior tone quality from Sterling Eliminators is no accident. It is the result of perfected engineering design, coupled with the selection of the finest materials obtainable, regardless of their cost.

And what about dependability? The answer is *quality first*, and big production only on the basis of real merit. Sterling "B" units are giving thousands of radio owners complete satisfaction. These are the reasons why dealers are selling more every day—because the Sterling stays sold.

There's a Sterling "B" Eliminator for every man who enters your store, whether he has a



Exact adjustment of both detector and amplifier voltages — a Sterling quality feature.

2-tube or a 10-tube set including the latest power tube combinations. Try Sterling "tone quality" Eliminators on the guarantee of power and dependability — eliminate your troubles.

Sterling "B" ELIMINATORS

Write for information about Sterling's line of tube testers, battery chargers and other accessories that meet every Radio buying need.

THE STERLING MFG. CO.



2831 Prospect Ave., Cleveland, O.

*For the small Apartment—
For the man of Moderate Income—
For the Young Married Couple.*

It's Here!

**Shamrock's
New Model B**

*For people who live in small apartments where a large radio is an encumbrance—the new model B is ideal! Why? because SHAMROCK—enterprising as usual—designed this new radio to fill this very need. It is a *Baby Grand Console*—just the size to fit into a small living*

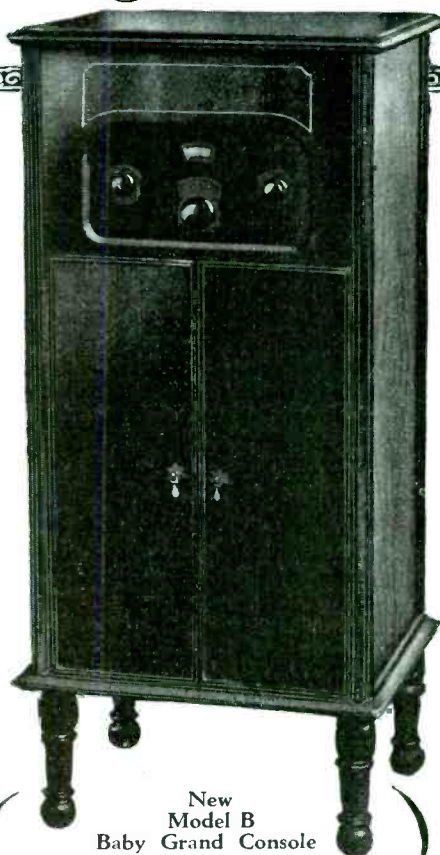

New
Model B
Baby Grand Console

Six tube perfected single dial control. Resistance Coupler Amplification. Operated from house current with most any standard equipment. Without built in loud speaker. Ample room for A and B batteries.

Price only \$115
Slightly higher
West of the Rockies

room—and handsomely finished in fine woods.

For the man of moderate income—and the young couple just starting in housekeeping the SHAMROCK Model B is a positive find! It is a handsome piece of furniture that adds to the beauty of any home and at the same time a high class radio carrying the assurance of perfect performance!

**MODEL B
Your Biggest Profit Maker**

Because it has such a *broad* appeal SHAMROCK found on investigation that there were thousands of people in the country who wanted just such a radio as Model B. Cash in on this valuable market!

SHAMROCK
RADIO SETS

SHAMROCK MANUFACTURING COMPANY
Makers of Famous SHAMROCK STANDARD PARTS
196-204 Waverly Avenue, Newark, New Jersey

SANDAR

S P E A K E R

IT SPEAKS FOR ITSELF

THE remarkable record of Sandar, the new cone speaker, since its introduction some months ago, speaks for itself in loud tones! All over the country it has won a prominent position in the radio field. Fans, convinced by one demonstration, are praising and clamoring for it, dealers are stocking to meet the demand, the manufacturers are speeding up production—and all is Sandar activity.

Plenty of reasons for Sandar's success, particularly its mechanical excellence and attractive appearance plus—a strong selling point—its exceptionally low price, \$27.50, lower than that of any other licensed speaker of its size. There is still some Sandar territory available if you act quickly. So write today for terms and full information.

SANDAR CORPORATION

Crescent Plaza Building Long Island City, New York

Licensed under
Lektophone Patents

\$ 27.50

West of the Rocky Mountains, \$30



INSURED ---

A New Tube Free for any ARCHATRON That Fails to Give Satisfactory Service FOR ONE YEAR



Type UX-201-A



Type UX-199

Unprecedented protection for sellers and buyers of radio tubes. Not merely a promise but a binding twelve months guarantee. Every ARCHATRON dealer is authorized to make good at our expense this guarantee.

"Any Ken-Rad ARCHATRON not subjected to excessive voltage is guaranteed unconditionally for one year."

Other tubes begin to die on the day they are born. ARCHATRONS retain all their "pep" and vitality for a lifetime averaging much longer than one year.

The *SEVEN-TEST* Tubes

KEN RAD

ARCHATRONS

Absolutely Uniform in Every Electrical Characteristic

AN ARCHATRON FOR EVERY NEED	
UX 201-A	Detector-Amplifier
UX 199	Detector-Amplifier
UX 112	Power Amplifier
UX 120	Power Amplifier
UX 200-A	Super Detector
UX 216-B	Single Wave Rectifier
UX 213	Double Wave Rectifier
UX 100-A	Hi-Mu Resistance Coupled Amplifier

Every ARCHATRON must pass SEVEN severe tests before it leaves our laboratory.

- | | |
|-----------------------|-----------------------|
| 1. Amplification test | 4. Filament Life test |
| 2. Capacity test | 5. Vacuum test |
| 3. Volume test | 6. Uniformity test. |
| 7. Coordination test | |

Cost No More Than Other Standard Tubes

Mail this Coupon →

or write on your own letterhead and let us send you full information with prices.

THE KEN-RAD CORPORATION, INC.
318 Second Street, Owensboro, Ky.

THE KEN-RAD CORPORATION, INC.,
318 2nd St., Owensboro, Ky.

Please send information about ARCHATRON One-Year Guaranteed tubes, sales helps, and name of your nearest distributor.

Name

Address

City State

**Windsor Wall or Table
Type Cone Speaker
Amazes Radio World**

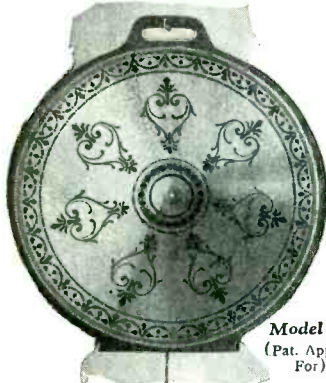

Model 210
(Pat. Applied For)

The latest model Windsor Cone Loudspeaker has astonished the world of radio. In convenience, quality of reception, and extremely low price, it far surpasses anything yet offered. The cone is 22 inches in diameter and is supported by an easel back. It can be hung up on the wall, as in the picture above, or stood upon any flat surface as shown in the picture below. It contains the famous Windsor loudspeaker unit noted for its extreme clarity and fidelity of reproduction.



Model 210
22-inch Cone Loudspeaker with easel back
\$15.00
(West of Rockies \$18)
(Pat. Applied For)

**Model 302 (Shown below)
With Moulded Composition Horn Loudspeaker and 18-inch Cone Loudspeaker.**



(Pat. Applied For)
In this Windsor Console is combined both the Windsor Moulded Composition Horn Loudspeaker and the 18-in. Windsor Cone Loudspeaker. The top is 30 in. x 17 in. and stands 29 in. high. Plenty of battery and equipment space is provided by large shelf in rear. Price, finished in Mahogany or Walnut **\$48.00**
(West of Rockies, \$55)

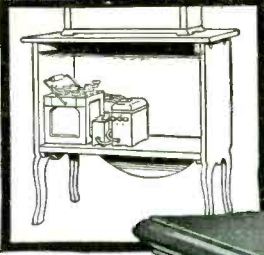

Rear view at left shows large compartment with ample space for batteries, battery charger, or battery eliminator, which are entirely concealed from view. Back is open for ventilation of batteries.

At right is shown the Cone Loudspeaker, with its panel, which is quickly and easily removable, allowing instant access to all batteries, battery charger, battery eliminator or other equipment and wiring.

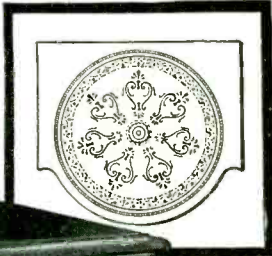

Model 200
\$29
Console with Cone Loudspeaker Ready for Set and Batteries
(West of Rockies, \$35)

(Pat. Applied For)
Model 200—with 22-inch Cone Loudspeaker
This Windsor Cone Loudspeaker Console is equipped with a 22-inch Windsor Cone Loudspeaker. Its top is 30" x 17" and is 29" high. The battery shelf provides ample space for batteries, charger, battery eliminator and other equipment. Beautifully finished in either Mahogany or Walnut.

This is the Fastest Selling Line of Loudspeakers and Loudspeaker Consoles in the Radio World Today



Model 100
with Moulded Composition Horn Loudspeaker or 16-inch Cone Loudspeaker
(Pat. Nov. 18, 1924)

Above is shown a beautiful Windsor Loudspeaker Console, finished in either Walnut or Mahogany, which provides ample space on top for any radio set. The battery shelf beneath will accommodate all necessary equipment. Equipped with either Moulded Composition Horn or 16-inch Cone Loudspeaker. Size: 38 in. x 18 in., and 29 in. high. Price **\$40.00**
(West of Rockies, \$42.50)

To the right is shown the newest Windsor Loudspeaker Console. It is equipped with a 22-inch Cone Loudspeaker and cabinet suitable for 7-inch radio panels up to 26 inches in length. Battery shelf provides ample space for all equipment. Beautifully finished in either Walnut or Mahogany. Price (without receiving set) **\$44.00**
(West of Rockies, \$52.00)

Note to Dealers: Write or wire today for details of the highly profitable Windsor line.

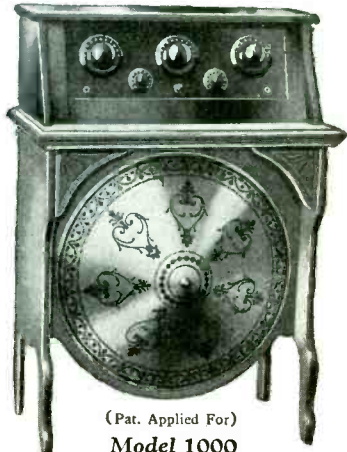

(Pat. Applied For)
Model 1000
with 22-inch Cone Loudspeaker

Electrical Department
WINDSOR FURNITURE COMPANY
1436 Carroll Avenue • CHICAGO, ILLINOIS
Los Angeles Branch—917 Maple Avenue

Two types fill every need in "A" power units



\$29⁵⁰

TYPE A

\$34⁵⁰

TYPE AX

Prices slightly higher
west of Rockies

HERE is an "A" power unit that costs only 1 cent a day to operate. That's the actual cost of electric current. Losses in the transformer and in the full-wave rectifier have been cut down to a minimum. That's why it costs so little to run. It is the most efficient type of trickle-charged "A" power unit.

Such economy, plus the fact that the prices are materially under the market, makes this a quick seller. Made in two types. Each has a specially built Prest-O-Lite radio battery, 6 volts, 40 ampere-hours, designed to carry a large volume of electrolyte, thus eliminating the necessity of frequent watering. Charger is silent, full wave, without bulbs, liquids or moving parts, indestructible. Charging rate adjustable. Everything in a compact metal case with carrying handle.

Type A—supplies "A" current only and has automatic relay, turning charger off when set is turned on.

Type AX—In addition has connection for "B" power, making the radio receiver 100% automatic power operated.

Prest-O-Lite also makes standard radio "A" batteries, 60, 80, 100, 120 ampere-hour capacities. The addition of these Trikl-Automatic "A" Power Units to the standard line now makes the Prest-O-Lite contract even more valuable than ever before. Write us for full details.

THE PREST-O-LITE CO., INC., INDIANAPOLIS, IND.
New York San Francisco

Unit of Union Carbide and Carbon Corporation

Prest-O-Lite

A Real Sales Maker

Made of selected genuine Mahy. or Amer. Walnut Ply-wood. Finished two tone Antique Brown Mahy. or American Walnut. Battery Compartment, High grade Loud Speaker Wood Horn and **UTAH LOUD SPEAKER UNIT COMBINED**, 30-in. High, 32-in. Wide, 15-in. Deep. Average shipping weight 62 lbs. Price Antique Brown Mahy. \$36.00. Price, Antique Amer. Walnut \$36.75. Write for liberal jobber and dealers discounts.



Radio Console No. 505

Exclusive United States Sales Representatives

SANFORD BROS.

CHICAGO, ILL.
30 W. Walton Place

CHATTANOOGA, TENN.
615 Broad St.
SAN FRANCISCO, CAL.
311 Mina St.

SEATTLE, WASH.
Amer. Bank Bldg.

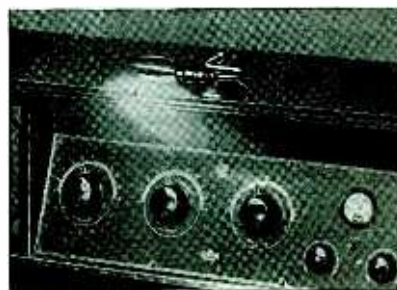

A Wonderful Radio Light

THROWS a concentrated non-glaring light just where you want it. Gracefully curved extension casts light down at proper angle. Adjustable shade. Weighted base of molded white metal prevents tipping. Finished in a rich bronze over all. Standard socket plug. Uses a candelabra lamp. Extra long silk cord. Size 2½ in. high by 7½ in. from front to back.

A big seller at low retail price of \$3.85. Write for details and attractive discounts.

VIMCO MFG. COMPANY, Inc.

Manufacturers of Nationally Known "Bend-O-Lite"
721-B Ellicott Square, Buffalo, N. Y.

RADIO VIMCO LIGHT



CLIP TIME OFF WIRING JOBS BY USING



Approved by the Underwriter Lab.
Cartons of 100 — Standard Package 1000

Get Free Working Samples Sign Below and Mail

Name _____

Address _____

COLT'S PAT. FIRE ARMS MFG. CO., HARTFORD, CONN.



An Insulating Cap with a split screw that bites twisted wire ends.

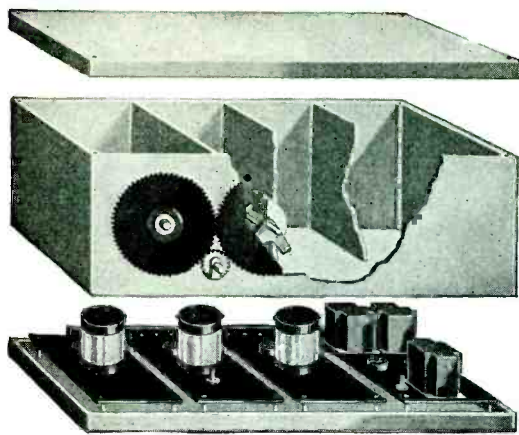

***This Construction
Makes Satisfied Owners***

The old policy of "quality first" gets real results this year just as it has every other year.

Questions of pride aside, Slagle has never built anything but the best sets he knows how, because he wants every set he sells to be a good will maker. That's why you'll always find Slagle sets equipped with every tested improvement. No radical changes every year, because basic design is scientifically correct. Materials and workmanship are everything that money and experience can obtain.

Our selling policies and helps combine with a good set to make an attractive proposition for first class dealers. Wouldn't you like to know all about it?

Let us tell you

SLAGLE RADIO COMPANY
Fort Wayne, Indiana

Slagle Radio

**THE HYATT 6-TUBE PORTABLE
RADIO RECEIVER—NEW MODEL**



A portable radio receiver of highest quality and substantial construction for the home, hotel, club, hospital.

Selective, Long Range, Tone Quality and Volume.

Employing 6-C 299 or UV 199 Tubes, 3 Standard Dry Cells, 2 Burgess No. 4308 "B" Batteries and 1 No. 5360 Burgess "C" Battery.

Equipment includes Loop, Aerial, Inbuilt Speaker with Unit, Single Dial Control.

Enclosed in Black Leatherette Covered and Well Built Cabinet 15-in. wide, 11 1/2-in. high and 9 1/4-in. deep. Wt. 14 lbs. less tubes and batteries, 28 lbs. fully equipped.

LIST PRICE
Less Accessories
\$85.00
F.O.B. CHICAGO, ILL.

LIST PRICE WITH FULL EQUIPMENT
\$105.00

Jobbers and Distributors
Join us in the distribution of this Wonderful Receiver.
Write for our Plan and Discounts

Dealers
If your Jobber can not serve you, write us for our Circular and Discounts.

THE ELECTROPHONE CORPORATION
109 NO. WABASH AVE., CHICAGO, ILL.

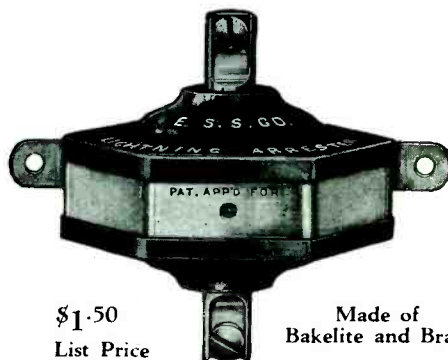

\$1.50
List Price

Made of
Bakelite and Brass

Keystone is the one lightning arrester the radio public knows by name and relies upon for performance.

You can sell Keystone profitably at the nationally advertised price of \$1.50.

ELECTRIC SERVICE SUPPLIES COMPANY

Philadelphia 17th & Cambria Sts. New York 50 Church St. Chicago Illinois Merchants' Bank Bldg.

KEYSTONE
RADIO LIGHTNING
ARRESTERS

A SENSATION!

Electric Window Flasher

with Changeable Letters

IF YOU WANT
THE BEST
GET IT
HERE

SPECIFICATIONS
Price Letters—6 in. high
Reading—1½ in. high
Opal Glass Background. Beautifully Framed. Antique Finish. Light flashes on and off without motor.

DAY and NIGHT SIGN
Brilliant by Day — Startling at Night

Only **\$15.00** [100 Letters and 22 Numerals FREE with each sign if you order from this advertisement.]

Fully Guaranteed

CHANGEABLE LETTERS enable this sign to be used for any purpose—to say anything—at all times.

Other signs up to \$45.00

WRITE FOR DETAILS

NATIONAL SIGN CO.
124 West 18th St., New York City

AERIAL KITS

Style "A" \$3.50
Style "B" \$2.00



Everything that is necessary for the installation of an efficient aerial and ground system. Easy to install. Easy to buy. Easy to sell.

Attractively packed in display box



Nifty Ground Clamp (shown at left) requires no tools and is easily adjusted to commonly used pipe. Made of tinned copper and brass. No soldering necessary.



Nifty Lead-in (shown below) completely weatherproof, pliable, and insulated. No holes to bore. Fits easily under window or door tightly closed.



MANUFACTURING COMPANY
60 India St. BOSTON, MASS.

ACME

CELATSITE BATTERY CABLE

—a silk-covered cable of vari-colored Flexible Celatsite wires, for connecting batteries to set. Prevents "blowing" of tubes; gives your set an orderly appearance.

Stranded Enameled Antenna
Best outdoor antenna you can buy. 7 strands of enameled copper wire; maximum surface for reception. Prevents corrosion and consequent weak signals.

The Original Celatsite
—a tinned, copper bus bar wire with non-inflammable "spaghetti" covering, for hook-ups. 5 colors; 30-inch lengths.
We also offer the highest grade of "spaghetti" tubing for Nos. 10 to 18 wires. 5 colors; 30-inch lengths.

Flexible Celatsite
Flexible, stranded wire for point-to-point and sub-panel wiring. Non-inflammable "spaghetti" covering. In black, yellow, green, red and brown; a color for each circuit. Put up in 25-foot coils.





Dealers Write for Acme Wire Products Folder E
THE ACME WIRE CO. - New Haven, Conn.

ACME WIRE

MAKES BETTER RADIO

The NEW! Accessory ♦

\$1.00 List

Good Profit

This decorative silk cord hanger for Cone Speakers, making it possible to eliminate all unsightly wires, is creating tremendous interest.

Copper wires to speaker concealed in the silk cord. Equipped with phone tips for connecting the speaker, and provision is made behind the rosette for connection to wire from set.

Women like it because it is decorative and keeps all wires out of sight. Furnished in several colors.

Speaker manufacturers, jobbers and dealers are offered a real proposition.

Jobbers—Dealers—Write for samples and particulars.

Cone Speaker Manufacturers—Adds another sales feature to your speaker. Write for details.



No wires showing! Copper wires to the speaker are concealed in the cord

Rosenblum & Co., Inc.

11 West 19th St., New York City



The New Balkite Charger

MODEL J. Has a low trickle charge rate and a high rate for rapid charging and heavy duty use. Can thus be used either as a trickle or as a high rate charger and combines their advantages. Noiseless. Large water capacity. Visible electrolyte level. Rates: with 6-volt battery, 2.5 and .5 amperes; with 4-volt battery, .8 and .2 ampere. Special model for 25-40 cycles with 1.5 amperes high rate. Price \$19.50. West of Rockies \$20. (In Canada \$27.50.)



Balkite Trickle Charger

MODEL K. For those who require a charger of limited capacity only. Can be left on continuous or trickle charge thus automatically keeping the battery at full power. Converts the "A" battery into a light socket "A" power supply. Charging rate about .5 ampere. Over 300,000 in use. Price \$10. West of Rockies \$10.50. (In Canada \$15.)



Three New Balkite "B"s

Balkite "B" eliminates "B" batteries and supplies "B" current from the light socket. Noiseless. Permanent. Employs no tubes and requires no replacements. Three new models. The new popular priced Balkite "B"-W at \$27.50 for sets of 5 tubes or less requiring 67 to 90 volts. Balkite "B"-X, (illustrated) for sets of 8 tubes or less; capacity 30 milliamperes at 135 volts—\$42. Balkite "B"-Y, for any radio set; capacity 40 milliamperes at 150 volts—\$69. (In Canada "B"-W \$39; "B"-X \$59.50; "B"-Y \$96.)



Balkite Combination

When connected to the "A" battery supplies automatic power to both "A" and "B" circuits. Controlled by the filament switch on the set. Entirely automatic in operation. Can be put either near the set or in a remote location. Will serve any set now using either 4 or 6-volt "A" batteries and requiring not more than 30 milliamperes at 135 volts of "B" current—practically all sets of up to 8 tubes. Price \$59.50. (In Canada \$83.)

All Balkite Radio Power Units operate from 110-120 volt AC current with models for both 60 and 50 cycles. The new Balkite Charger is also made in a special model for 25-40 cycles.

Now is the real selling season for Light Socket Radio Power Devices

*Keep your radio department
operating at a profit by pushing Balkite
—the standard line in this field*

Your greatest problem during the coming months is to keep your radio department operating at a profit. It can be done. It's entirely a question of choosing the right lines to push, of concentrating on those which can be sold in volume.

Balkite is one of those lines. During the 1925-26 season the sales of Balkite Radio Power Units were 15% greater after than before January 1st. With Balkite the selling season is 60 to 90 days later than that of most radio lines.

This is logical. Every sale of a radio set creates a Balkite prospect. In a few cases the Balkite sale is made at the time the set is sold, but usually it follows a month or two later. That is why Balkite sales continue to mount months after the peak in set sales is passed.

True as this has been in past years, it will be even more true this year. Never has public interest in light socket radio power devices been so great; never have sales been so large. And as usual Balkite is the leader in this field.

Take advantage of this situation for your profit. Feature Balkite, which you know will sell, for the coming months. Prolong your selling season 60 to 90 days, and keep your radio department operating at a profit.

FANSTEEL PRODUCTS COMPANY, Inc.
North Chicago, Illinois

Balkite Radio Power Units

Even in These Hectic Days of Interfering Stations, Here's One Line of Radio Sets that Piles Dollars in the Cash Register and Makes Them Stick!

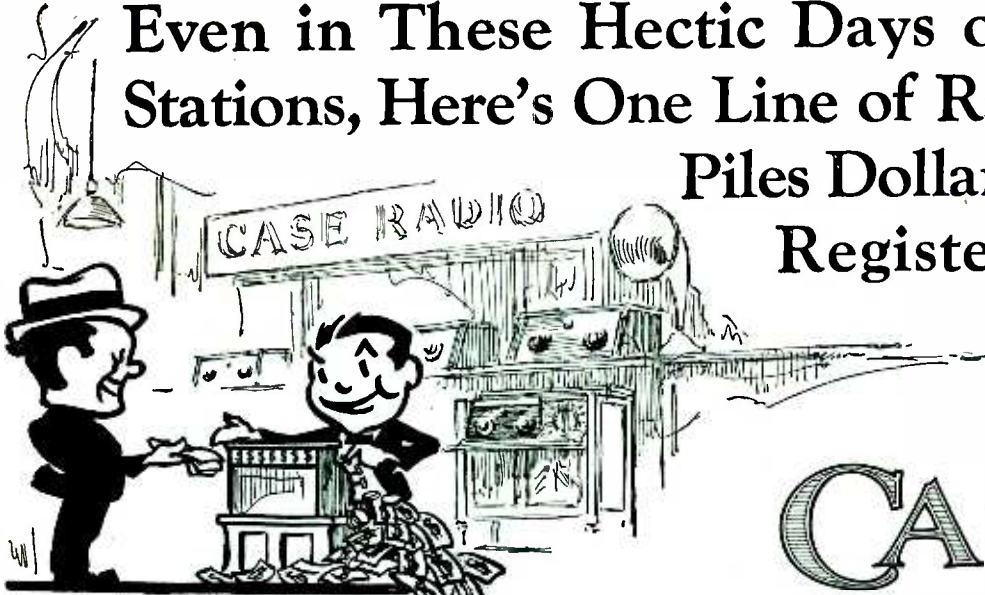

CASE SIX TUBE SETS

The present well-known "jumble in the air" hasn't stopped CASE dealers. For in addition to ample volume, artistic cabinets and attractive low prices, CASE Sets boast a remarkable degree of

SELECTIVITY!

The buyer of a CASE Set is a satisfied customer—every sale sticks. Sales are easy, for a demonstration under present broadcasting conditions will amaze the beginner or old-timer.

A Better Product Backed by a Well Established Organization

CASE 6-tube sets have five years of successful performance to their credit. They are built complete in one factory, assuring perfect matching of all units and making possible unusually low prices for such precision instruments. CASE national advertising reaches millions, and constructive sales program helps dealers.

Write today for complete information regarding our liberal profit-building franchise

Indiana Mfg. and Electric Co.
Marion, Indiana

Two Members of the CASE Line



New table type CASE set; 3/4-inch solid mahogany cabinet; dual vernier control; list **\$85**



New type "C" CASE console; beautiful two-tone walnut cabinet with built-in speaker; standard CASE circuit of tuned radio frequency with six tubes and dual vernier control; list **\$135**



NEW Full-Wave Gas Rectifier Tubes

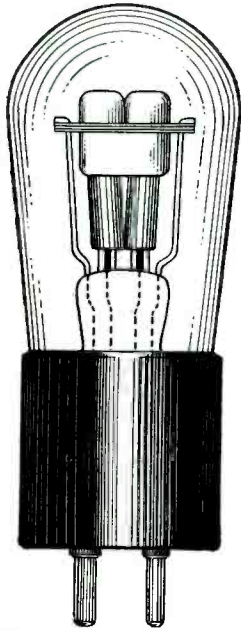

60 Milliamps - - - - \$6.00
85 Milliamps - - - - \$6.00

Guaranteed. Made under our own patent applications. We *do not* use the old short path principle.

We also have some news regarding an A, B and C Eliminator without batteries or charger, if you are interested.

Write for dealers' or manufacturers' discounts; or better, order samples for comparison tests.

R. G. Dun or Bradstreets will tell you our guarantee is good.

The Q.R.S Music Co.
306 S. Wabash Ave., Chicago

The **HANDY** "A" Power Unit

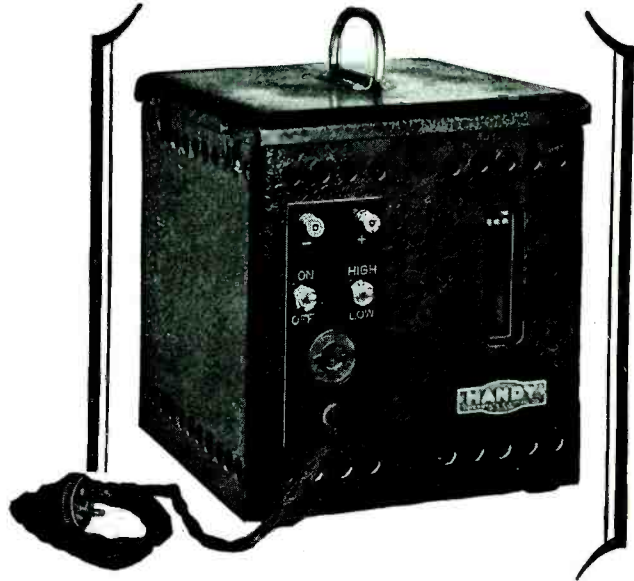

An Advanced Model
in this popular unit, by Interstate

BEARING an enviable reputation for producing fine chargers over a period of years, Interstate engineers offer the HANDY "A" Power Unit as the finest in this type of charger that has yet been developed. The Willard glass "A" battery is of advanced design, equipped with visible hydrometer gauge showing the strength of the battery at all times. The *trickle-booster* type of charger used in connection is built entirely of oversized parts and has proven to be the most practical and dependable. It supplies a constant flow of $\frac{1}{2}$ ampere charging rate when the set is not in use. If the battery shows the slightest weakening a push of the small toggle switch to the "high" side, will send a fast charge of 2 to $2\frac{1}{2}$ amperes which will restore the battery to full strength in a few hours.

\$40⁰⁰
COMPLETE
with Willard glass
battery. \$42.50 with
automatic relay.

Dealers and jobbers know that HANDY chargers have always been dependable, and that Interstate gives the utmost in guarantees to all its rectifiers. Order several of these units and learn how hundreds of dealers are profiting by handling the Interstate line of Handy Chargers. Write to-day.

INTERSTATE ELECTRIC COMPANY
4351 Duncan Ave. St. Louis, U. S. A.

INTERSTATE

Profits for You Satisfaction for Your Customers



Quick Sales—
Assured
Profits
Repeat
Business

*The Tube
of
Longer
Life*

*A Type
for Every
Radio Need*

Makes a Good Receiver Better
Write for Complete Data Sheet
C. E. MFG. CO. Inc. . . . PROVIDENCE . R. I.

The Enchanter Radio Cone Speaker

A RICHLY decorative radio cone speaker capable of reproducing the entire tonal scale with true, full fidelity. Operates equally well without or with power tube.

*T*HIS strikingly beautiful radio cone speaker makes an instantaneous appeal to the eye. The cast metal galleon is hand decorated in polychrome colors of silver grey, green, yellow and red.

Sells at \$30 list.

National Distributors

Baker-Smith Co., Inc.

Call Bldg.,
San Francisco, Calif.



Height 15 in., Diameter 13 in.



Licensed Under Pats. Granted and Pending.

ELKAY

Truphonic Senior "6" Designed for All-Year Reception

The extreme sensitivity of the Senior practically overcomes the summer lack of distance, and makes it an all-year investment. You can sell the Senior in any of the summer months and thus even up much of your former hot weather slump.

Besides exceptional DX-ability, the Senior has the following good points:

- (1) Wonderfully rich, natural tone in good volume, due to high-grade parts, careful designing, and 3 stages of Truphonic amplification.
- (2) Elkay (patented) Synauto R.F., which permits smooth tuning over the entire band, from 200 - 580 meters, without readjustment of filaments.
- (3) Ability to cut through the locals clean and clear and bring in outside stations in pleasing quality.
- (4) Complete shielding against "strays" and interstage coupling.
- (5) Uni-control; the flexibility of three dials in one.

Price, in handsome slope-front antique, natural grain mahogany, Duco finished, \$125 without accessories. Write for franchise.

Ready Now—

ELKAY JUNIOR "6"



The "Junior" is Elkay quality through and through. It is a T. F. R. receiver built after the most approved practice of the day. Shielded coils, cushioned detector, simplified dual thumb dial tuning, combined transformer and resistance coupling. Designed for those who want Elkay quality and precision engineering but who cannot afford to invest more than \$80, which is the price minus accessories. Write for folder.

THE LANGBEIN-KAUFMAN RADIO CO.

Dept. M, 62 Franklin St., New Haven, Conn.

New Radio Conditions

—NEW WESTON RADIO INSTRUMENTS

THE dealer owes it to himself to handle only such devices as will perform satisfactorily. When you sell a Battery Eliminator show its performance by testing it with a Weston Model 489 Battery Eliminator Voltmeter—it will assure customer confidence. ¶ This double range battery eliminator voltmeter has a very high internal resistance (1,000 ohms per volt) which means that only a very slight amount of current (one milliampere for full scale deflection) is drawn from the eliminator for its operation.



WESTON ELECTRICAL INSTRUMENT CORPORATION

25 Weston Avenue, Newark, N. J.



The New and Improved INVERSE DUPLEX is making a "hit" in radio sales circles

The first direct "hit" is the R. G. S. Receiver. A group of ten manufacturers, including The National Company, Samson Electric Company, Sangamo Electric Company, Hammarlund Mfg. Co., Central Radio Laboratories, Arthur H. Lynch, Inc., De Jur Company, as well as ourselves, are co-operating in merchandising this R. G. S. Receiver kit-set. The R. G. S. Receiver, using the *new and improved Inverse Duplex Circuit*, has definitely proved itself as the answer to the chaotic broadcasting conditions existing today—particularly as to *selectivity*.

In addition to this R. G. S. Receiver kit-set, the Grimes Radio Engineering Company, Inc., will in the immediate future market two models of radio receivers employing this new and improved Inverse Duplex Circuit and incorporating many features of tremendous performance and merchandising importance.

Radio merchants want to sell products that have little sales resistance and that are asked for by name. The R. G. S. Receiver kit-set is one of them; and the completed receivers to be produced by this company will likewise have immediate national consumer acceptance.

We have a very definite sales policy to tell you about, and suggest that you let us tell you quickly. Just drop a letter or wire, asking for our sales proposition.

GRIMES RADIO ENGINEERING CO. INC.
GRASMERE - STATEN ISLAND - NEW YORK.

GRIMES RADIO

The Improved Amplion Cone

The instantaneous acceptance of this fine new model is due to its success in the greatest test of Cone type speakers—clear, clean reproduction of speech.

National magazine advertising carrying this thought to over 6,000,000 readers a month is helping all Amplion Dealers to increase their sales.



Model AC12
List \$30.00

The new improved Amplion Patrician which assembles a 48-in. air-column in a hand-carved mahogany cabinet 18 in. x 12 in. x 9 in. is now listed at \$50.00.

Do not fail to investigate the sales possibilities of these fine new Amplion models.

THE AMPLION CORPORATION of AMERICA
Suite E, 280 Madison Ave., New York City
The Amplion Corporation of Canada Ltd., Toronto



Sell Udell Radio Cabinets

A good example of our stock line of Radio Cabinets and Tables is No. 746 illustrated at left.



UDELL covers a complete range in design, finish and price. See our permanent displays—spaces 1029-31 American Furniture Mart, Chicago; space 314, New York Furniture Exchange, 206 Lexington Ave. Write for complete catalog R-86 and dealer's discounts.

We also build special Radio Cabinets under contract.

Write your requirements.

THE UDELL WORKS, INC.
28th Street at Barnes Ave.,
INDIANAPOLIS, IND.



A-B Relay

The Jewell A-B Relay is the automatic, trickle charger and B eliminator switch which your customers have been asking for. It switches the trickle charger and B eliminator automatically when the filament switch is snapped.

There is some good profit for dealers in this set accessory. Be sure to get your share.

Write for descriptive circular 1023

JEWELL ELECTRICAL INSTRUMENT CO.
1650 Walnut St., Chicago
"27 Years Making Good Instruments"



A-B Relay—
A sure profit maker



Unipower AC-6-HA, for 201-A Tubes or equivalent—\$42.50.
AC-4, for 199 tubes or equivalent—\$33.00.

Why UNIPOWER cuts Service Costs

UNIPOWER is easy to sell to your customers. It gives them automatic radio "A" power from their light sockets—gives them power operation under one control—"A" and "B" from the radio set switch.

Unipower cuts your service costs in many ways. For example:

1. *Ease of installation*—Unipower requires no special wiring. It is far easier to install than a storage battery and charger combination.
2. *Guards against overcharge*—The automatic cut-off principle in the rectifying cell of Unipower is an exclusive Gould feature and guards against damaging overcharge.
3. *Corrosion avoided*—There is no bi-metallic construction in Unipower's battery compartment. This feature and the lead wire used in all connections eliminate corrosion and internal electrical resistances.

Unipower employs the proven trickle charge plus an indispensable rapid charge rate. A simple dial adjustment sets the trickle charge rate to the requirements of any particular set.

Write us or your jobber for full details of this profitable line. Gould Storage-Battery Co., Inc., 250 Park Avenue, New York City.

Unipower is manufactured by the makers of the famous Gould Batteries for automobiles, submarines, railways, farm-lighting, fire alarm service and emergency city-power

Unipower

A GOULD PRODUCT

AUTOMATIC "A" POWER WITH "B" POWER CONTROL

**SOMETHING
NEW!**

**SOMETHING
BETTER!**



"A & B" Power Unit

It consists of a six volt storage battery with a capacity of sixty ampere-hours; also an Acme B Power Supply Unit, a Two Rate Acme Trickle Charger giving 1/2 and 1 1/2 amperes, (this being controlled by a toggle switch) and the Acme Automatic Control Switch.

Attractive Container

These units are enclosed in a permanently attractive steel case finely finished with crystalline lacquer. Bulbs for both the charger and B Eliminator together with the necessary cord and sockets are included.

This Acme A & B Power Unit will keep the battery on any Radio Receiving set properly charged regardless of the number of tubes in the set. It is automatic in operation and is controlled by the switch at set.

It is the most efficient unit on the market

Price **\$67⁵⁰** East of the Rockies

OTHER ACME RADIO PRODUCTS OF REPUTE

Acme Automatic Control Switch	Acme Universal B Supply Unit
Acme Trickle Charger	Acme 2 Rate Trickle Charger
Acme Universal Type AU Charger	Acme A Power Unit

Write today for descriptive literature.

**THE ACME ELECTRIC AND
MANUFACTURING CO.**

1435 Hamilton Avenue, CLEVELAND, OHIO

ACME FLEXIBLE CELATSITE

Flexible, stranded wire for point-to-point and sub-panel wiring. Non-inflammable "spaghetti" covering. In black, yellow, green, red and brown; a color for each circuit. Put up in 25-foot coils.



The Original Celatsite

—a tinned, copper bus bar wire with non-inflammable "spaghetti" covering, for hook-ups. 5 colors; 30-inch lengths.



Celatsite Battery Cable

—a silk covered cable of vari-colored Flexible Celatsite wires, for connecting batteries to set. Prevents "blowing" of tubes; gives your set an orderly appearance. We also offer the highest grade of "spaghetti" tubing for Nos. 10 to 18 wires. 5 colors; 30-inch lengths.



Stranded Enameled Antenna

Best outdoor antenna you can buy. 7 strands of enameled copper wire; maximum surface for reception. Prevents corrosion and consequent weak signals.



Dealers Write for Acme Wire Products Folder E
THE ACME WIRE CO. - New Haven, Conn.

ACME WIRE
MAKES BETTER RADIO

HARTUNG Continuous Circuit -Bulldog Grip CLIPS



Don't Crystallize

Hartung Clips are made in one piece, of special composition, heat-treated spring steel. No danger of crystallizing. They provide a certain continuous current path with low resistance. Growing in popularity by leaps and bounds because of outstanding dependability.

Order from your jobber or let us send you a trial carton direct.

C. F. HARTUNG CO.
728 E. 61st St., Los Angeles, Calif.

DEALERS ALL OVER THE WORLD
 There's Money for you
 in putting Radio Batteries
 in the cellar



PREMIER EXTENSION CORD and CABLE sells easily and fast because it enables radio owners to do what they want:—hide their batteries in the cellar and extend the loud speaker onto the porch or into the next room. "Standard New Code" Insulation

used exclusively. Cord and cable comes in all lengths, standard and special. Jobbers everywhere. Low prices with attractive dealer discounts. Act now for biggest season just ahead. For nearest jobber's name, write to Crescent Braid Co., Providence, R. I.

The advent of the power tube makes an Extension Cord necessary to preserve true tone.

Orders accepted through any New York Export House. Inquiries solicited from Dealers, Distributors, Jobbers, in all parts of the world. Catalogs and literature gladly furnished.



Crescent Braid, Inc.,
 289 to 297 Thurber Ave., Providence, R. I., U. S. A.

SEARCHLIGHT SECTION

SURPLUS STOCKS—BUSINESS OPPORTUNITIES

UNDISPLAYED—RATE PER WORD:
 Positions Wanted, 6 cents a word, minimum \$1.25 an insertion, payable in advance.
 Positions Vacant and all other classifications, 10 cents a word, minimum charge \$2.00.
 Proposals, 40 cents a line an insertion.

INFORMATION:
 Box Numbers in care of any of our offices count 10 words additional in undisplayed ads.
 Discount of 10% if one payment is made in advance for four consecutive insertions of undisplayed ads (not including proposals).

DISPLAYED—RATE PER INCH:
 1 to 3 inches.....\$6.65 an inch
 4 to 7 inches..... 6.40 an inch
 8 to 14 inches..... 6.20 an inch
 Rates for larger spaces, or yearly rates, on request.
 An advertising inch is measured vertically on one column, 3 columns—30 inches—to a page.

Radio Retailing

POSITIONS WANTED

RADIO and music department buyer and manager desires change. Age 37. Thorough radio man and musician. Take full charge of merchandising and servicing. New England preferred. \$3,500 for radio, \$5,000 for combination radio, pianos, victrolas, etc. Address Radio Service, 274 Main St., Worcester, Mass.

SALESMAN WANTED

Salesmen Wanted
 One each for Pittsburgh, Baltimore, New Jersey; radio sets, speakers, eliminators, storage batteries, etc., to distributors; commission. Vernon H. Walker, 1600 Arch St., Philadelphia, Pa.

REPRESENTATIVE WANTED

Agent Wanted
 German radio house wants first-class agent for U. S. A. to call on retail dealers and jobbers for radio parts; best connections and references necessary; knowledge of German desirable. RW-28, Radio Retailing, Tenth Ave. at 36th St., New York.

FOR SALE

For Sale
 One basic patent and several additional patents pending, pertaining to an exceptionally good radio loudspeaker, designed by an expert instrument maker. Terms cash and royalty, or outright sale. FS-29, Radio Retailing, Tenth Ave. at 36th St., New York.

W
E
P
A
Y

Liquidate Your Surplus RADIO STOCK
 Highest prices paid for surplus radio cabinets, sets and parts. Any quantity.
 What have you to sell?
GENERAL RADIO SET CO.
 74 Cortlandt St., N. Y. C.

C
A
S
H

FOR SALE

1—Preiss Straight (8) eight \$85.00.
 1—Gould A.C. 4-Unipower \$20.00.
 Guaranteed New.
 Reason for selling, changing line.
OWEN BROS. HARDWARE CO.,
 Shelbyville, Ky.

NEED DISTRIBUTORS?

Advertise for them in the "Searchlight Section"

Manufacturer's Representative

With office in Chicago, can handle a desirable Radio or Electrical line in Middle West.
 AS-27, Radio Retailing
 7 So. Dearborn Street, Chicago, Ill.

TURN THAT SURPLUS STOCK INTO CASH

Advertise it in the "Searchlight Section"

ALPHABETICAL INDEX TO ADVERTISEMENTS

Page	Page
Acme Elec. & Mfg. Co.120	General Electric Co.Front Cover
Acme Wire Co.113-120	General Radio Co.88
Allen-Bradley Co.95	Gold Seal Electrical Co.4
Aluminum Co. of America.97	Goodrich Tire & Rubber Co.97
American Insulator Corp.98	Gould Storage Battery Co., Inc.119
Amoroso Mfg. Co.113	Goyer Co.98
Amplion Corp. of America119	Grebe, A. H. & Co., Inc.3
Amrad Corp.20	Grimes Radio Eng. Corp.118
Atwater Kent Mfg. Co.30	
	Hammalund Mfg. Co.94
Bakelite Corp.13	Hartung Co., C. F.120
Baker-Smith Co., Inc.117	Hazeltine Corp.26
Boudette Mfg. Co.16	Hood Rubber Co.98
Briggs & Stratton Corp.19	
	Igrad Condenser Mfg. Co.96
C. E. Mfg. Co.117	Indiana Mfg. & Electric Co.115
Colt's Pat. Fire Arms Mfg. Co.111	International Resistance Co.21
Cornish Wire Co.98	Interstate Elec. Co.116
Crescent Braid, Inc.121	
Crosley Radio Corp.85	Jewell Elec. Instrument Co.119
Cunningham, Inc., E. T. Inside Front Cover	
	Karas Elec. Co.102
Delta Electric Co.11	Kellogg Switchboard & Supply Co.27
Deutschmann Co., Tobe86	Ken-Rad Corp., Inc.109
Dry Storage Battery Corp.9	
Dubilier Condenser and Radio Corp.102	Langbein-Kaufman Radio Co., The.117
Dudlo Mfg. Corp.99	
	Modernola Co.98
Eagle Charger Corp.122	
Eby Mfg. Co., H. H.92	National Carbon Co., Inc.28
Electrad, Inc.97	National Sign Co.113
Electric Service Supplies112	
Electrical Research Laboratories103	Peerless Electric Co.24
Electrophone Corp.112	Popular Science Monthly7
Fansteel Products Co., Inc.114	Positions Wanted121
Farrand Mfg. Co., Inc.18	Prest-O-Lite Co., Inc.111
Federal-Brandes Corp.22-23	
Federal Radio Corp.104	Q. R. S. Music Co.116
Ferranti, Inc.100	Zetka Laboratories, Inc.15
Freed-Eisman Radio Corp.12	
Frost, Herbert H., Inc.94	
	Radio Corp. of America 46-47-Back Cover
	Radio Master Corp.68-69
	(Pictorial Section)
	Raytheon Mfg. Co.14
	Reliable Parts Mfg. Co., The.96
	Rola Co.6
	Rosenblum & Co., Inc.113
	Sandar Corp.108
	Santford Bros.111
	Searchlight Section121
	Shamrock Mfg. Co.107
	Sickles Co., F. W.94
	Silver Marshall96
	Slagle Radio Co.112
	Sprague Specialties Co.101
	Standard Piano Bench Mfg. Co.122
	St. James Lab. Inc.94
	Sterling Mfg. Co.106
	Stewart Warner Speedometer Corp.17
	Stromberg-Carlson Tel. Mfg. Co.2
	Superb Electric Co.105
	Sylvania Prod. Co.25
	Tower Mfg. Corp.5
	Udell Works, Inc.119
	United Radio & Electric Corp., Inside Back Cover
	Universal Winding Co.101
	Utah Radio Products Co.1
	Van Doorn Co.101
	Vesta Battery Corp.29
	Vinco Mfg. Co.111
	Watson Table & Furniture Co.8
	Weston Elec'l Inst. Corp.118
	Windsor Furniture Co.110
	Wireless Specialty Apparatus Co.90
	Wirt Co.10

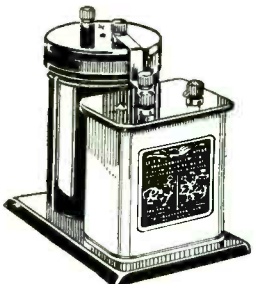

Eagle "TRICKLER"

Charges "A", Storage "B" and Rechargeable Dry "B" Batteries. Shipped Dry and Uses No Harmful Acids. Terminals Won't Corrode. Costs less than 2c. a day to operate. Sells for only \$10.

If your jobber can't supply you, write direct to us

EAGLE CHARGER CORPORATION
121 North Eighth St., Philadelphia, Penna

More Radio Cabinet Sales

This Standard No. 401 Radio Cabinet was designed to be highly attractive and to be most practical. Users find that it fully meets their needs.

A number of features including wood horn, make this a cabinet you should consider at once.

Made in Antique Brown Mahogany or Antique Burl Walnut finish. Write for dealers' transportation allowance and discount list.

STANDARD PIANO BENCH MFG. CO.
1221-1227 W. Lake St.
Chicago, Ill.

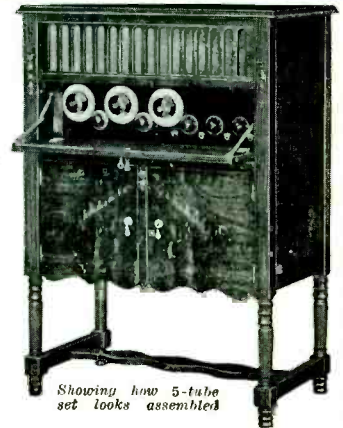

Showing how 5-tube set looks assembled



Right Tubes are your best outside salesmen

When your customers have guests in their homes, strangers hear the sets you sell. And when talk starts on radio buying, it naturally turns to dealers.

So the one safe thing to do is to see that every

set you sell is equipped with the best of tubes, for the tubes, as you know, are the heart of any set.

Up to recently, though, not even dealers could be sure about how tubes compare. But now, at last, you can be absolutely positive.

Sell URECOS and they'll sell for you

You can now recommend URECO tubes with the assurance that they'll be doing a good job for your reputation in the customer's home. For one of the leading electrical laboratories of the country recently made a test of the best-known radio tubes on the market.

And URECO came *first*—by an astonishing margin.

A report has been made of this test. For many reasons you may be amazed to read it—it tells you things about some tubes you probably haven't suspected.

We'll let you have an exact copy of this report on request. And if you wish, we'll be glad, at the same time, to tell you about some very unusual methods the makers of URECOS are using to help dealers on the resale of URECO tubes.

The coupon below is for your convenience

*Fill out and mail
the coupon TODAY*

United Radio & Electric Corp.

418-420 Central Ave., Newark, N. J.

URECO Radio Tubes

"More sensitive than a musician's ear"

United Radio & Electric Corp.,
Newark, N. J.

Gentlemen:

I am interested in the comparative test given the best-known radio tubes in a leading electrical laboratory recently. Please, without obligation on my part send me an exact copy of the report made by the laboratory on this test.

Name

Address

City State



RADIOTRON UX-22-A	Detector Amplifier
RADIOTRON UX-109	Detector Amplifier
RADIOTRON UX-109	Detector Amplifier
RADIOTRON WD-41	Detector Amplifier
RADIOTRON UX-42	Detector Amplifier
RADIOTRON UX-300	Detector Only
RADIOTRON UX-200-A	Detector Only
RADIOTRON UX-120	Power Amplifier Last Audio Stage Only
RADIOTRON UX-12	Power Amplifier
RADIOTRON UX-71	Power Amplifier Last Audio Stage Only
RADIOTRON UX-210	Power Amplifier Oscillator
RADIOTRON UX-213	Full-Wave Rectifier
RADIOTRON UX-216-B	Half-Wave Rectifier
RADIOTRON UX-274	Voltage Regulator Tube
RADIOTRON UX-875	Ballast Tube
RADIOTRON UX-888	Ballast Tube
RADIOTRON UX-277	Protective Tube



This ad is one of the brilliant color-pages running every month all the year round in a long list of the most important national magazines.

SEEING MORE THAN THE MICROSCOPE

clear up the tone

Do you get a blast when you turn the volume up a bit? Do you get sweet, clear tone at low volume, but noise when it's louder? The trouble's probably right in one tube—the tube in the last audio stage. The Radiotron laboratories discovered that no ordinary tube can let big volume through clearly. Change one tube to an RCA power Radiotron. The tone up the volume . . . and it comes through clear!

RCA

RADIO CORPORATION OF AMERICA 665 N. WOLFE CHICAGO SAN FRANCISCO

RCA Radiotron

MADE BY THE MAKERS OF THE RADIOLA

Have you ever figured the cost of a dissatisfied customer? . . . Then you know you can afford to sell nothing but *the best in vacuum tubes.*

Many years of experience developing and making MAZDA lamps have given to the Radiotron laboratories and factories a skill that cannot be matched. RCA Radiotrons are far ahead in quality—and always will be. And they are far ahead of all competitors in sales. Surely gambling with inferiors doesn't pay!

RADIO CORPORATION OF AMERICA
New York Chicago San Francisco

RCA Radiotron

MADE BY THE MAKERS OF THE RADIOLA